

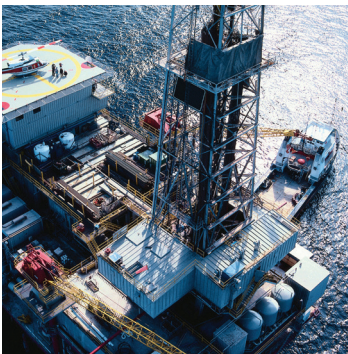

aerospace  
climate control  
electromechanical  
filtration  
fluid & gas handling  
**hydraulics**  
pneumatics  
process control  
sealing & shielding



# Denison GOLD CUP® Product Catalog Piston Pumps & Motors

For Open & Closed Circuits

HY28-2667-01/GC/NA,EU  
Effective: July 23, 2019



ENGINEERING YOUR SUCCESS.

## Hydraulic Pump Division and Denison Hydraulics

The Hydraulic Pump Division of Parker Hannifin was formed in 2004 when our significant piston pump business was expanded through the acquisition of Denison Hydraulics. The addition of Denison allowed us to marry the wealth of knowledge that both companies have in the design, manufacture, and application of piston products in both open circuit and closed circuit system applications. Since before WWII, Denison products have been chosen for Military test stand applications and for shipboard hydraulic applications being recognized as technology leaders.

The heavy duty **GOLD CUP®** series of pumps and motors in this catalog represent a broadening of our product offering with hydrostatic transmission applications in marine, drilling, and shredding applications, among others. The tried and true design of the **GOLD CUP®** product line incorporates features such as integral servo and replenishing pump, hot oil shuttle, and a unique servo control system; all of which combine to provide a rugged self contained package which can withstand the harshest of conditions and continue to perform with trouble free long life.

The division is a leading worldwide manufacturer of hydraulic components and systems for earthmoving and construction vehicles; for mining equipment; for pulp and paper, chemical and other processing equipment; for ships and ordnance equipment; and for such in-plant machines as machine tools, plastic molding, die casters, and stamping presses.



The product information, specifications, and descriptions contained in this publication have been compiled for the use and convenience of our customers from information furnished by the manufacturer; and we can not, and do not, accept any responsibility for the accuracy or correctness of any description, calculation, specification, or information contained herein. No such description, calculation, specification, or information regarding the products being sold has been made part of the basis of the bargain, nor has same created or amounted to an express warranty that the products would conform thereto. We are selling the goods and merchandise illustrated and described on this publication on an "as is" basis, and disclaim any implied warranty, including any warranty of merchantability or warranty of fitness for any particular purpose whatsoever, with respect to the goods and merchandise sold. All manufacturer warranties shall be passed on to our customers, but we shall not be responsible for special, indirect, incidental, or consequential damages resulting from the use of any of the products or information contained or described on this publication. Further, we reserve the right to revise or otherwise make product improvements at any time without notification.



### **WARNING - USER RESPONSIBILITY**

**FAILURE OR IMPROPER SELECTION OR IMPROPER USE OF THE PRODUCTS DESCRIBED HEREIN OR RELATED ITEMS CAN CAUSE DEATH, PERSONAL INJURY AND PROPERTY DAMAGE.**

This document and other information from Parker-Hannifin Corporation, its subsidiaries and authorized distributors provide product or system options for further investigation by users having technical expertise.

The user, through its own analysis and testing, is solely responsible for making the final selection of the system and components and assuring that all performance, endurance, maintenance, safety and warning requirements of the application are met. The user must analyze all aspects of the application, follow applicable industry standards, and follow the information concerning the product in the current product catalog and in any other materials provided from Parker or its subsidiaries or authorized distributors.

To the extent that Parker or its subsidiaries or authorized distributors provide component or system options based upon data or specifications provided by the user, the user is responsible for determining that such data and specifications are suitable and sufficient for all applications and reasonably foreseeable uses of the components or systems.

### **OFFER OF SALE**

The items described in this document are hereby offered for sale by Parker-Hannifin Corporation, its subsidiaries or its authorized distributor. This offer and its acceptance are governed by the provisions stated in the detailed "Offer of Sale" elsewhere in this document.

© Copyright 2019, Parker Hannifin Corporation. All Rights Reserved.

Mining Photo on Front Cover is the Property of Atlas Copco.

# Contents

<b>Contents</b> .....	<b>3</b>
<b>Technical Data</b> .....	<b>4</b>
<b>Features</b> .....	<b>7</b>
<b>Description</b> .....	<b>8</b>
<b>Pump, Motor Dimensions</b>	
P6, 7, 8 .....	11
M6, 7, 8 .....	15
P11, 14 .....	18
M11, 14 .....	22
P24, 30 .....	25
M24, 30 .....	30
<b>Controls Dimensions</b>	
10, 2A .....	35, 42
2H, 4A.....	36
5A, 5C.....	37, 42
7D, 7J .....	38
7F, 7K .....	39
8A, 8C.....	40, 43
9A, 9C.....	41, 43
**4 .....	44
**6, **8, **2.....	45
<b>Rear Adapters</b>	
Table.....	46
P6, 7, 8 .....	47-48
P11, 14 .....	47, 49-52
P24, 30 .....	52-55
<b>Inlet Conditions</b> .....	<b>56</b>
<b>Performance Curves</b> .....	<b>57-62</b>
<b>Pump Primary Displacement Control Options</b> .....	<b>63-70</b>
<b>Secondary Control Options</b> .....	<b>71-72</b>
<b>Hydraulic Schematics</b> .....	<b>73-77</b>
<b>GOLD CUP® Pump Control Combinations</b> .....	<b>78</b>
<b>Pump Ordering Code</b> .....	<b>79-80</b>
<b>GOLD CUP® Motor Control Combinations</b> .....	<b>82</b>
<b>Motor Ordering Code</b> .....	<b>83-84</b>
<b>Offer of Sale</b> .....	<b>89</b>

Series	Terms	P6	P7	P8	P11	P14	P24	P30		
<b>Displacement</b>	<i>Max. displacement</i>	in <sup>3</sup> /rev.	6.00	7.25	8.00	11.00	14.00	24.60	30.60	
		cm <sup>3</sup> /rev.	98,3	118,8	131,1	180,3	229,5	403,2	501,5	
<b>Pressure</b>	<i>Continuous</i>	psi	5000	5000	5000	5000	5000	5000 <sup>1)</sup>	5000 <sup>1)</sup>	
		bar	350	350	350	350	350	350 <sup>1)</sup>	350 <sup>1)</sup>	
	<i>Intermittent</i>	psi	6000 <sup>7)</sup>	6000 <sup>7)</sup>	5000	6000 <sup>7)</sup>	6000 <sup>7)</sup>	5500 <sup>1)7)</sup>	5500 <sup>1)7)</sup>	
		bar	420 <sup>7)</sup>	420 <sup>7)</sup>	350	420 <sup>7)</sup>	420 <sup>7)</sup>	370 <sup>1)7)</sup>	370 <sup>1)7)</sup>	
<b>Speed (Pump)</b>	<i>max. @ full stroke</i>	rpm	3000	3000	2700	2400	2400	2100 <sup>2)</sup>	1800	
		<i>(Motor)</i>	rpm	3000	3000	2700	2400	2400	2100 <sup>2)</sup>	1800
			<i>max. @ 50% stroke</i>	rpm	3600	3600	3000	2800	2800	2100 <sup>2)</sup>
<b>Mounting</b>	<i>Flange -2 bolt</i>	SAE	127-2 (C)	127-2 (C)	127-2 (C)	-	-	-	-	
		SAE	152-4 (D)	152-4 (D)	152-4 (D)	165-4 (E)	165-4 (E)	177-4 (F)	177-4 (F)	
	<i>Shaft - keyed</i>	SAE	32-1 (C)	32-1 (C)	32-1 (C)	44-1 (E)	44-1 (E)	50-1 (F)	50-1 (F)	
		SAE	44-1 (D)	44-1 (D)	44-1 (D)	-	-	-	-	
	<i>Shaft - splined</i>	SAE	32-4 (C)	32-4 (C)	32-4 (C)	44-4 (E)	44-4 (E)	50-4(F)	50-4 (F)	
<i>splined</i>	SAE	44-4 (D)	44-4 (D)	44-4 (D)	-	-	-	-		
<b>Weight (Pump) less controls</b>		lbs	175-300	175-300	175-300	325-530	325-530	750-835	750-835	
	<i>Mass</i>	kg.	80-135	80-135	80-135	145-240	145-240	340-375	340-375	
<b>Weight (Motor Fixed)</b>		lbs	110	110	110	250	250	510	600	
	<i>Mass</i>	kg.	50	50	50	110	110	230	270	
<b>Weight (Motor Variable) less controls</b>		lbs	110	110	110	300	300	650	670	
	<i>Mass</i>	kg.	50	50	50	135	135	290	300	
<b>Rotating inertia</b>		lbs-in <sup>2</sup>	92	92	92	290	290	821	977	
		kg.m <sup>2</sup>	0,027	0,027	0,027	0,085	0,085	0,240	0,286	
<b>Torque (Motor) theo. max.</b>	<i>per 100 psi</i>	lbs-in	95.5	115.4	127	175	222	392	487	
		Nm	157	189	208	287	362	623	797	
	<i>at 5000 psi</i>	lbs-in	4774	5769	6366	8750	11100	19576	24351	
		Nm	539,5	651,9	717	990	1250	2158	2752	
<b>Power (Motor) theo. max.at 5000 psi, 350 bar</b>	<i>per 100 rpm</i>	hp	7.6	9.2	10	13.8	17.6	31.1	38.6	
		kW	5,7	6,8	7,5	10,3	13,1	23,1	28,8	
	<i>at 2000 rpm</i>	hp	151.5	183.1	201,5	277.8	353.5	621.3	695	
		kW	113,0	136,6	152	207,0	263,7	463,5	518,2	
<b>Torque (Motor) efficiency - approx. stalled</b>	<i>running</i>	% theo.	81	81	81	81	81	81	81	
	<i>running</i>	% theo.	93	93	93	93	93	93	93	
<b>Case pressure: max. allowable</b>	<i>continuous</i>	psi	75	75	75	75	75	75		
		bar	5,2	5,2	5,2	5,2	5,2	5,2	5,2	
	<i>intermittent</i>	psi	125	125	125	125	125	125	125	
		bar	8,6	8,6	8,6	8,6	8,6	8,6	8,6	
<i>(Not to exceed 25 psi, 1,7 bar above inlet in open circuit units)</i>										
<b>Flow (Pump) theo.at max.displ. @ 1500 rpm</b>		gpm	39	47	52	71	91	160	199	
		lpm	148	178	197	269	344	606	753	
	<i>@1800 rpm</i>	gpm	47	57	62	86	109	192	238	
		lpm	178	216	235	326	413	727	901	
<b>Displacement</b>	<i>(Internal aux. pump)</i>		<b>P6,7,8P,S,V</b>	<b>P11,14P,S</b>	<b>P11,14V</b>	<b>P24P</b>	<b>P24S<sup>3)</sup></b>	<b>P30P</b>	<b>P30S<sup>3)</sup></b>	
		in <sup>3</sup> /rev.	1.07	(2) 1.07 <sup>4)</sup>	1.07 <sup>5)</sup>	2.81 <sup>6)</sup>	2.81 <sup>6)</sup>	2.81 <sup>6)</sup>	2.81 <sup>6)</sup>	
		cm <sup>3</sup> /rev.	17,5	(2) 17,5	17,5	46,1	46,1	46,1	46,1	
<b>Flow (Internal aux. pump)</b>	<i>@1500 rpm</i>	gpm	6.9	(2) 6.9	6.9	18.2	6.5	18.2	6.5	
		lpm	26,1	(2) 26,1	26,1	68,9	24,6	69,1	24,6	
	<i>@1800 rpm</i>	gpm	8.3	(2) 8.3	8.3	21.9	7.8	21.9	7.8	
		lpm	31,4	(2) 31,4	31,4	82,9	29,5	82,9	29,5	

1) Max. pressure 5000 psi, (350 bar) for M24 and 30 series variable motors. Higher servo pressure may be required - consult Parker.

2) On HF-1 fluids, 1800 RPM Max. on HF-0 fluids.

3) Internal cartridge provides servo flow and must be supercharged from external replenishing flow, from external auxiliary pump.

4) One servo cartridge and one replenishing cartridge.

5) Servo cartridge only.

6) Standard, other sizes available, see ordering code.

7) 10% of operation time, not exceeding 6 successive seconds.

**Technical Data****Hydrostatic Transmission Piston Pumps  
GOLD CUP® Series - Open & Closed Circuits**

		<b>P6,7,8,11,14,24P</b>	<b>P6,7,8,11,14,24S</b>	<b>P30P</b>	<b>P30S</b>
<b>Replenishing pressure</b> ( <i>Internal aux. pump</i> )		180-220	*180-220	180-220	*180-220
<i>Replenish pressure minus case pressure</i>	psi	12,4-15,2	12,4-15,2	12,4-15,2	12,4-15,2
	bar	308-420	308-420	308-420	308-420
<b>Servo pressure</b> ( <i>Internal aux. pump</i> )	psi	21,2-29,0	21,2-29,0	21,2-29,0	21,2-29,0
<i>Servo pressure minus case pressure</i>	bar	500-650	500-650	500-650	500-650
<i>at 0 psi, 0 bar discharge pressure</i>		34,5-44,8	34,5-44,8	34,5-44,8	34,5-44,8
<b>Servo pressure</b> ( <i>Internal aux. pump</i> ) <sup>(Above repl.)</sup>	psi				
<i>for HI-IQ control units. Servo pressure minus</i>	bar				
<i>case pressure at 5000 psi, 350 bar discharge pressure - at system pressure range 0 to 5000 psi, 350 bar.</i>					

\*Note: Nominal setting, may be increased if required.

<b>Series</b>	<b>Terms</b>	<b>P6</b>	<b>P7</b>	<b>P8</b>	<b>P11</b>	<b>P14</b>	<b>P24</b>	<b>P30</b>
<b>Controls</b>								
Compensator response (per SAE J497 @ <b>5000 psi</b> , 350 bar)	off-stroke sec.	0.05	0.05	0.05	0.07	0.07	0.10	0.10
	on-stroke sec.	0.9	0.9	0.9	1.5	1.5	1.8	1.8
Compensator adjustment	<b>psi/turn</b>	<b>2000</b>	<b>2000</b>	<b>2000</b>	<b>2000</b>	<b>2000</b>	<b>2000</b>	<b>2000</b>
	bar/turn	138	138	138	138	138	138	138
Torque to turn rotary servo shaft	<b>in.-lbs</b>	<b>20</b>	<b>20</b>	<b>20</b>	<b>20</b>	<b>20</b>	<b>20</b>	<b>20</b>
	Nm	2,3	2,3	2,3	2,3	2,3	2,3	2,3

The maximum inlet at the auxiliary pump inlet is 200 psi. (13,8 bar)

Minimum compensating pressure will always be 100-200 psi. (6,9-13,8 bar) over servo pressure.

Any inlet pressures above atmospheric will increase noise levels and decrease efficiencies noted in this literature. Exact measurements depend on each application and operating conditions. Please consult your nearest Parker Office for further details.

\*Standard factory compensating pressure is 1,000 psi. (69,0 bar).

**REAR DRIVE TORQUE CAPACITY**

SERIES	FRONT INPUT SHAFT		REAR MOUNTINGS SAE						REAR OUTPUT SHAFT TORQUE CAPACITY
	TYPE	TORQUE CAPACITY	A	B	C	D	E	F	
P6,7,8 P,S,V,X,D	Keyed SAE 32-1(C) Spline SAE 32-4(C)	6920 in-lbs. (780 Nm)	•	•					1750 in-lbs. (195 Nm)
P6,7,8 P,S,V,X,D	Keyed SAE 44-1(D) Spline SAE 44-4(D)	6920 in-lbs. (780 Nm)	•	•					1750 in-lbs. (195 Nm)
P6,7,8 R,L	Keyed SAE 32-1(C)* Spline SAE 32-4C	13,845 in-lbs. (1565 Nm)	•	•	•				6920 in-lbs. (780 Nm)
P6,7,8 R,L	Keyed SAE 44-1(D) Spline SAE 44-4(D)	13,845 in-lbs. (1565 Nm)	•	•	•				6920 in-lbs. (780 Nm)
P11,14 P,S,V,X	Keyed SAE 44-1(E) Spline SAE 44-4(E)	13,370 in-lbs. (1510 Nm)	•	•	•				2400 in-lbs. (270 Nm)
P11,14 R,L only	Keyed SAE 44-1(E)* Spline SAE 44-4(E)	26735 in-lbs. (3020 Nm)	•	•	•	•	•	•	13,370 in-lbs. (1510 Nm)
P24,30 P,S,X	Keyed SAE 50-1(F) Spline SAE 50-4(F)	24350 in-lbs. (2750 Nm)		•	•				2700 in-lbs. (305 Nm)
P24,30 R,L only	Keyed SAE 50-1(F) Spline SAE 50-4(F)	48,700* in-lbs. (5,500 Nm)		•	•	•	•	•	24,350 in-lbs. (2750 Nm)

\* Coupling for keyed shaft must be pressed fit for full torque capability.

**P6/7/8 SAE 127-2 Mtg., 32-1, 4 Shaft Bearing 230-82140 (6007)**

Speed (rpm)	1000	1000	1000	1000	1200	1200	1200	1200	1500	1500	1500	1500	1800	1800	1800	1800
Shaft Load (lbs) *	0	0	1000	1000	0	0	1000	1000	0	0	1000	1000	0	0	1000	1000
Shaft Load (N) *	0	0	4448	4448	0	0	4448	4448	0	0	4448	4448	0	0	4448	4448
Case Pressure (psi)	0	25	0	25	0	25	0	25	0	25	0	25	0	25	0	25
Case Pressure (bar)	0.0	1.7	0.0	1.7	0.0	1.7	0.0	1.7	0.0	1.7	0.0	1.7	0.0	1.7	0.0	1.7
B-10 Life (hours x 1000)	8E+08	1833	0.778	0.778	6E+08	1528	0.648	0.648	5E+08	1222	0.518	0.518	4E+08	1018	0.432	0.432

**P6/7/8 SAE 152-4 Mtg., 44-1, 4 Shaft Bearing 230-00207-0 (6207)**

Speed (rpm)	1000	1000	1000	1000	1200	1200	1200	1200	1500	1500	1500	1500	1800	1800	1800	1800
Shaft Load (lbs) *	0	0	1000	1000	0	0	1000	1000	0	0	1000	1000	0	0	1000	1000
Shaft Load (N) *	0	0	4448	4448	0	0	4448	4448	0	0	4448	4448	0	0	4448	4448
Case Pressure (psi)	0	25	0	25	0	25	0	25	0	25	0	25	0	25	0	25
Case Pressure (bar)	0.0	1.7	0.0	1.7	0.0	1.7	0.0	1.7	0.0	1.7	0.0	1.7	0.0	1.7	0.0	1.7
B-10 Life (hours x 1000)	3E+09	7394	3.136	3.136	3E+09	6161	2.613	2.613	2E+09	4929	2.09	2.09	2E+09	4170	1.742	1.742

**P11/14 SAE 165-4 Mtg., 44-1, 4 Radial Shaft Bearing 230-82148-0 (6010) (2 & 3 Shaft Codes)**

Speed (rpm)	1000	1000	1000	1000	1200	1200	1200	1200	1500	1500	1500	1500	1800	1800	1800	1800
Shaft Load (lbs) *	0	0	1000	1000	0	0	1000	1000	0	0	1000	1000	0	0	1000	1000
Shaft Load (N) *	0	0	4448	4448	0	0	4448	4448	0	0	4448	4448	0	0	4448	4448
Case Pressure (psi)	0	25	0	25	0	25	0	25	0	25	0	25	0	25	0	25
Case Pressure (bar)	0.0	1.7	0.0	1.7	0.0	1.7	0.0	1.7	0.0	1.7	0.0	1.7	0.0	1.7	0.0	1.7
B-10 Life (hours x 1000)	2E+09	535	1.907	1.907	2E+09	446	1.589	1.589	1E+09	356	1.272	1.272	1E+09	297	1.06	1.06

**P11/14 SAE 165-4 Mtg., 44-1, 4 Spherical Roller Shaft Bearing 230-82214-0 (22208) (7 & 8 Shaft Codes)**

Speed (rpm)	1000	1000	1000	1000	1200	1200	1200	1200	1500	1500	1500	1500	1800	1800	1800	1800
Shaft Load (lbs) *	0	0	1000	1000	0	0	1000	1000	0	0	1000	1000	0	0	1000	1000
Shaft Load (N) *	0	0	4448	4448	0	0	4448	4448	0	0	4448	4448	0	0	4448	4448
Case Pressure (psi)	0	25	0	25	0	25	0	25	0	25	0	25	0	25	0	25
Case Pressure (bar)	0.0	1.7	0.0	1.7	0.0	1.7	0.0	1.7	0.0	1.7	0.0	1.7	0.0	1.7	0.0	1.7
B-10 Life (hours x 1000)	16856	2452	275	172	14046	2043	230	143	11237	1635	184	114.8	9364	1363	153	95.7

**P24 SAE 177-4 Mtg., 50-1, 4 Shaft Bearing 230-82213-0 (22311)**

Speed (rpm)	1000	1000	1000	1000	1200	1200	1200	1200	1500	1500	1500	1500	1800	1800	1800	1800
Shaft Load (lbs) *	0	0	1000	1000	0	0	1000	1000	0	0	1000	1000	0	0	1000	1000
Shaft Load (N) *	0	0	4448	4448	0	0	4448	4448	0	0	4448	4448	0	0	4448	4448
Case Pressure (psi)	0	25	0	25	0	25	0	25	0	25	0	25	0	25	0	25
Case Pressure (bar)	0.0	1.7	0.0	1.7	0.0	1.7	0.0	1.7	0.0	1.7	0.0	1.7	0.0	1.7	0.0	1.7
B-10 Life (hours x 1000)	591.6	428.5	276.7	213.5	493	357	230.5	178	394.4	991.6	184.4	142.3	328.7	238	153.7	118.6

**P30 SAE 177-4 Mtg., 50-1, 4 Shaft Bearing 230-82213-0 (22311)**

Speed (rpm)	1000	1000	1000	1000	1200	1200	1200	1200	1500	1500	1500	1500	1800	1800	1800	1800
Shaft Load (lbs) *	0	0	1000	1000	0	0	1000	1000	0	0	1000	1000	0	0	1000	1000
Shaft Load (N) *	0	0	4448	4448	0	0	4448	4448	0	0	4448	4448	0	0	4448	4448
Case Pressure (psi)	0	25	0	25	0	25	0	25	0	25	0	25	0	25	0	25
Case Pressure (bar)	0.0	1.7	0.0	1.7	0.0	1.7	0.0	1.7	0.0	1.7	0.0	1.7	0.0	1.7	0.0	1.7
B-10 Life (hours x 1000)	227	177.7	126.4	102.8	189.2	148	105.3	85.6	151.3	118.4	84.2	68.5	126.1	98.7	70.2	57.1

\*radial load at center of key or spline

Note: Variation in life is due to variations in tolerances within the pump.  
 Contact Parker Hydraulics for B-10 with other operating conditions and with other case pressure values.  
 Consult Parker Hydraulics for shaft side loads of P\*R units.



**Features**

**Hydrostatic Transmission Piston Pumps  
GOLD CUP® Series - Open & Closed Circuits**

- 1 Quick change valve block - easy to service or replace
- 2 Quick change controls - easy to service and change
- 3 Dampened low inertia rocker cam - more stable, quieter and faster than other designs
- 4 Exclusive zero-backlash rotary servo design - lifetime accuracy
- 5 Field adjustable compensator override - easily adjusted without removing from machinery
- 6 Precision barrel bearing, a distinctive Denison Hydraulics feature for over 30 years - permits high speeds, high pressure and provides long life
- 7 Versatile controls - can be located on either side of pump or motor for maximum freedom of design
- 8 Ring style replenishing checks fastest operation with no sliding poppets or parts and low pressure drop
- 9 Hot oil shuttle available - fast, reliable operation
- 10 Auxiliary pump can be changed without disassembling the transmission
- 11 Standard SAE keyed or splined drive shafts are available
- 12 High pressure mechanical shaft seals can be changed without disassembling the transmission. Double lip seals are also available
- 13 One piece stroking vane/cam means no lost motion, zero backlash, better control, and no linkages to wear out
- 14 Stroking vane seals are pressure loaded for longer life
- 15 Standard compensator vent ports allow for a wide variety of controls (See Applications Manual)
- 16 Rocker cam displacement indicator helps troubleshoot the system
- 17 Modulated servo pressure saves power
- 18 Standard Code 62 SAE split flange connections
- 19 Conforms to SAE mounting standards.
- 20 Fast compensator response. See page 5
- 21 Variable motors available for multiple speed ranges or constant power

Note: 1. These products, with exception of 8 cubic inch units, are qualified to meet Military specifications MIL-P-17869A and MIL-S-901-C Grade A.  
 2. All GOLD CUP® Pumps and Motors\* have ATEX approval.  
 \*See ordering code for availability.  
 3. Consult factory for other approvals such as ABS and Lloyd's Registry.

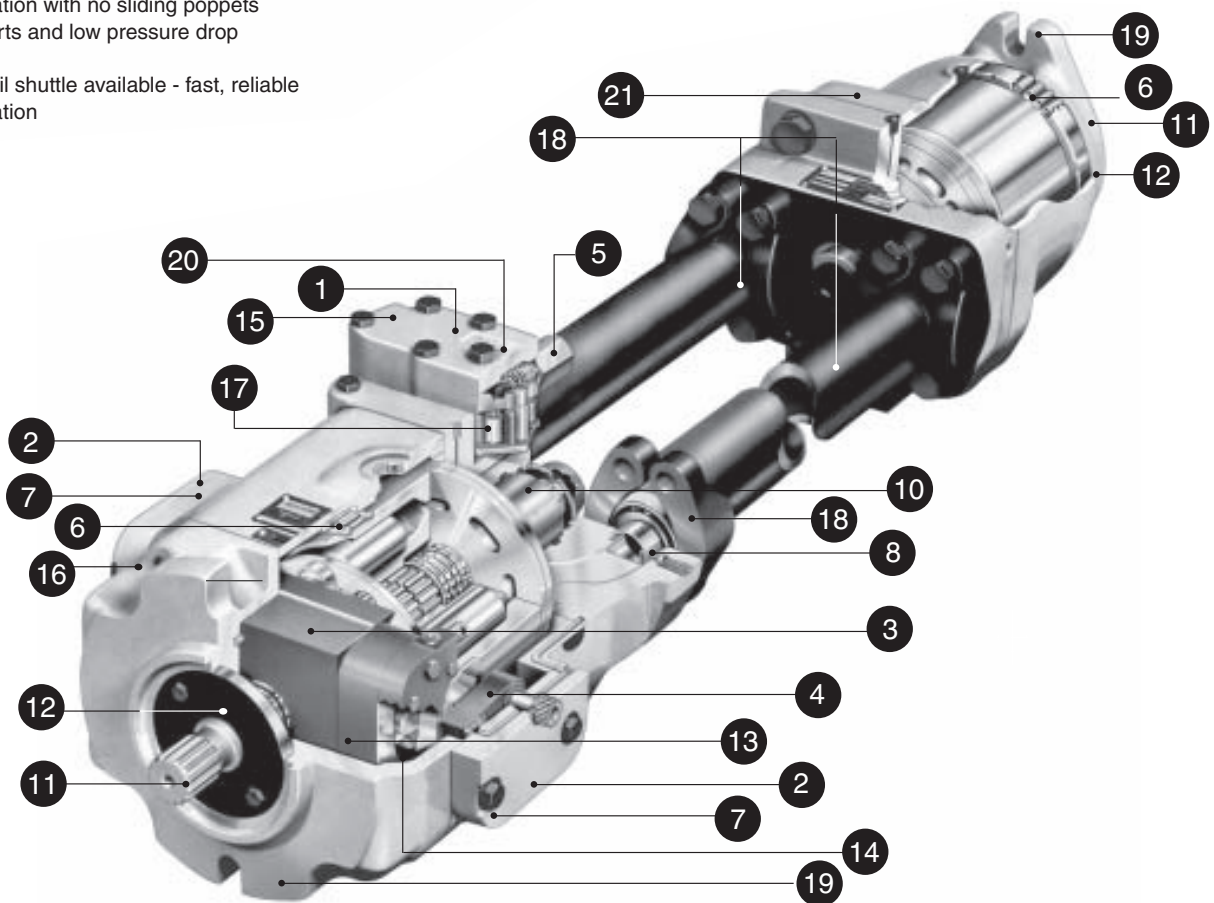

**Description****CLOSED HYDRAULIC CIRCUIT**

Variable Pump/Fixed Motor. This combination provides for a constant torque output at a fixed maximum pressure over the full speed range. Speed and direction are controlled with a variable displacement over-center pump. Power from overhauling loads is regenerated back into the pump prime mover. Motor speed is limited to the maximum speed permitted by full pump displacement. System is capable of full power only at maximum pump displacement.

**POWER CHARACTERISTICS OF HYDROSTATIC TRANSMISSIONS**

Variable Pump/Variable Motor. This combination provides for an extended range of motor speeds. The motor, at full displacement, delivers maximum torque while its speed and direction respond to displacement changes of the crossover center pump. Power is proportional to motor speed.

This transmission system has the capability of constant torque and rising power until the pump reaches full displacement and full power at elevated speeds as motor displacement and torque are reduced.

**PACKAGE PUMP**

The package pump contains the circuit elements shown in the hydraulic schematic on pgs. 72-74. These include the axial piston over-center variable displacement pump which controls the speed and direction of the motor, the auxiliary pump which supplies servo pressure (for controlling the displacement of the variable pump) and replenishment pressure, the servo pressure relief valve, the replenishment pressure relief valve and the replenishment check valves for ports A and B. The pump package also includes the displacement control valves as well as an external arm which shows actual displacement. The various control features are described below.

**PACKAGE MOTOR**

The package motor, shown in schematic pgs. 72-74, contains the axial piston fluid motor, the shuttle valve that continuously removes hot oil from the low pressure side of the loop and a relief valve to establish minimum hydraulic loop pressure at the motor. The fluid motor is available with fixed displacement or with the variable displacement option. The standard variable motors include an external indicator which shows displacement.

**OPEN CIRCUIT PUMP**

The open circuit pump contains the circuit elements shown on pages 75,76. These include a cross-center variable displacement pump which is normally limited to one side of center. The auxiliary pump supplies only servo pressure to control the main pump displacement and inlet porting is enlarged to improve the pump's inlet characteristics. As the open loop pump operates on one side of center only, not all controls are available.

**AUXILIARY REAR DRIVE**

Additional auxiliary flow is available with the rear drive pump option. The rear drive may also be utilized for servo and other purposes. See ordering code for additional detail.

"R" & "L" style pumps have no rear shaft seal, so any pump driven must be able to withstand case pressure of the pump driving it.

**AUXILIARY PUMP**

Integral to the package pump's envelope is the gerotor auxiliary pump. (P24P, P24S, P30P & P30S have vane integral pump). It provides servo and replenishing pressure. See page 5 for factory settings.

NOTE: Auxiliary pump inlet must be connected directly to the reservoir. Customer must supply external line from integral auxiliary pump back into main pump for filtering servo and/or replenishing oil. (see installation drawings starting on pg 10.)



**Description****MOUNTING**

The pump or motor is designed to operate in any position. For vertical mounting it is recommended that the shaft bearing be drained via the drain port provided.

The pump shaft must be in alignment with the shaft of the source driver and should be checked. The mating pilot bore and coupling must be concentric. This concentricity is particularly important if the shaft is rigidly connected to the driven load without a flexible coupling.

**Splined:** The shafts will accept a maximum misalignment of 0.15 mm (0.006 in.) total indicator reading. Angular misalignment at the external and internal spline axis must be less than  $\pm 0.002$  mm per millimeter of shaft radius ( $\pm 0.002$  in. per inch of shaft radius.) The coupling interface must be lubricated. PARKER recommends lithium molydisulfide or similar grease.

The internal coupling should be hardened to Rc 27-34 and must conform to SAE-J498c, class 5 flat root side fit.

Additional misalignment must be accommodated by the use of a flexible coupling. Please consult coupling manufacturer's guidelines for proper application.

**Keyed:** High-strength heat-treated keys must be used. Replacement keys must be hardened to 27-34 Rc. The key corners must be chamfered .075 – 1 mm (.030 in. – .040 in.) at 45° to clear radii that exist in the keyway. If a flexible coupling is not used, the alignment of keyed shafts must be within tolerances given for splined shafts.

**INLET PRESSURES,  
PORTS A & B**

In a closed hydraulic loop the pump inlet or the fluid motor inlet (during dynamic braking) are supercharged by the integral replenishment system. Consult Parker in cases where fluid viscosity or dynamics or line size may cause inlet pressure at either port A or B to be less than the 150 psi, 10,3 bar maintained by the integral replenishment system. For operation in open loop or combination open-closed loops, consult Parker.

**DRAIN PORT**

Drain the package pump from the higher drain port. If drain port is above the fluid level in the tank install a 5 psi, 0,3 bar relief of suitable size in the drain line to tank. For vertical mounting it is recommended that the shaft bearing be drained via the drain port provided.

For pump speeds intermittently below 1000 rpm, install a back pressure relief 40 psi, 2,8 bar of suitable size in the drain line from the higher port to tank. Motor case drain must be connected to pump case.

**Motor:** Drain the motor from the higher drain ports into the lower pump drain port or tank. Make provision that the motor drain port pressure will not exceed the maximum limits specified above.

**RETURN LINE FILTER**

Relatively inexpensive low pressure filters are recommended for installation in the return lines and drain lines from circuits using these pumps or motors. Consider the possibility of decompression surges and intensified flow in cylinder circuits as well as the factors above in selecting return line filters.

**AUXILIARY FLOW FILTERS**

It is recommended the auxiliary pump fluid be filtered to aid in maintaining acceptable cleanliness levels. For good filtration and reasonable maintenance intervals the filter capacity must be at least twice the auxiliary pump flow. To use this feature, install the isolation plug and connect the filter between ports G&H, (P6,P7,P8,P24,P30), or J&K (P11,P14). See detailed schematics and drawings pages 10-22 for location of these ports.

**RECOMMENDED FLUIDS**

The fluid recommended for use in these pumps and motors has a petroleum base and contains agents which provide oxidation inhibition and anti-rust, antifoam and de-aerating properties as described in Parker Denison standard HF-1. These preferred fluids do not contain anti-wear additives. Fluids containing anti-wear additives that meet Parker Denison standard HF-0 are acceptable.

**VISCOSITY**

Max. at cold start	7500 SUS, 1600 cSt
at low pressure, low flow and if possible, low speed	
Max. at full power	750 SUS, 160 cSt
Optimum for max. life	140 SUS, 30 cSt
Minimum at full power	60 SUS, 10cSt

**CLEANLINESS**

Particle contamination to meet ISO 20/17/14 or better. Water content < 500 ppm for mineral based fluids. For detail on fluid recommendations see bulletin SPO-AM305.

**P6-P7-P8F, M Dimensions**

**Hydrostatic Transmission Piston Pumps  
GOLD CUP® Series - Open & Closed Circuits**

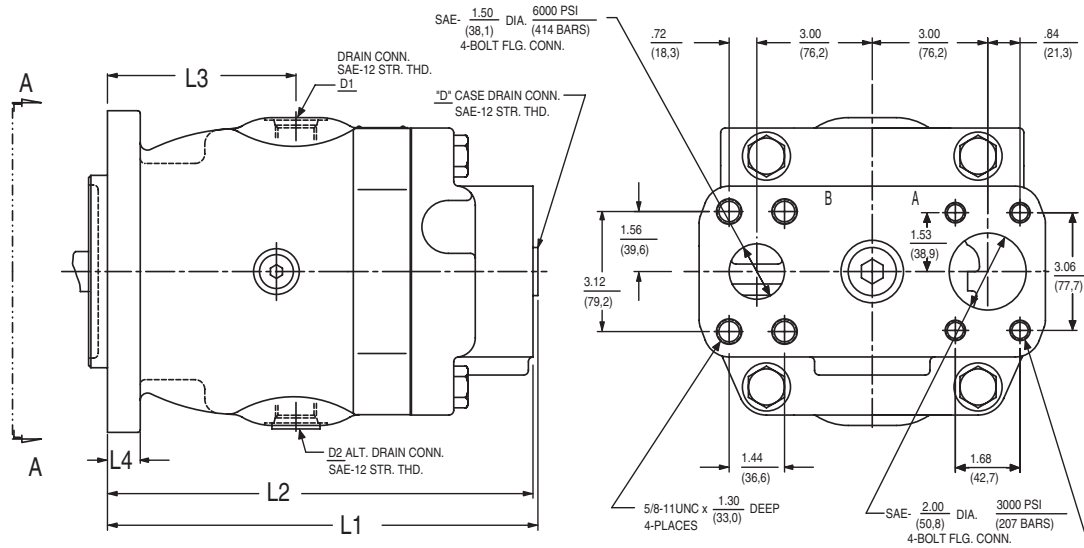

**P\*F**

MOUNTING	L1	L2	L3	L4
SAE 127-2 (SAE-C)	11.19 (284,2)	11.06 (280,9)	4.90 (124,5)	.85 (21,6)
SAE 152-4 (SAE-D)	11.59 (294,3)	11.46 (291,1)	5.30 (134,6)	.89 (22,6)

**P\*M**

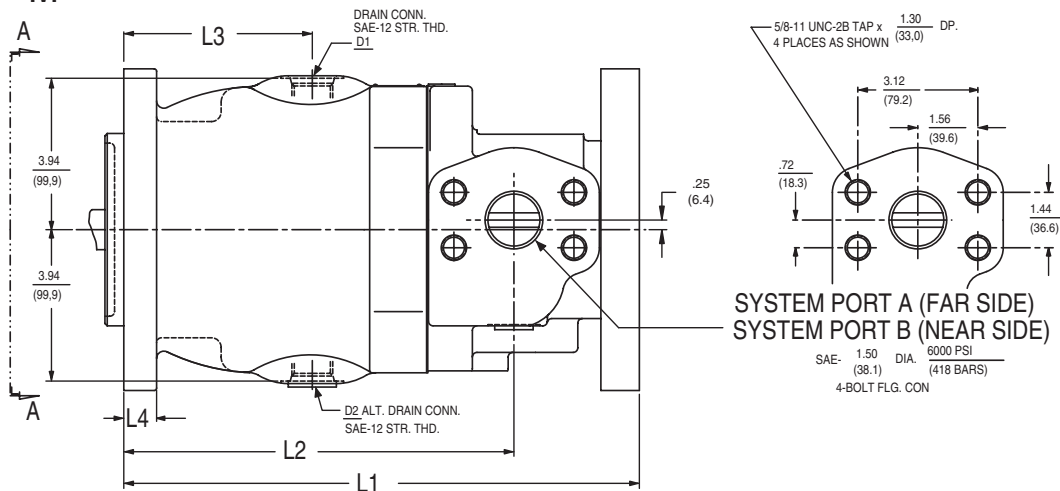

MOUNTING	L1	L2	L3	L4
SAE 127-2 (SAE-C)	13.40 (340,4)	10.14 (257,6)	4.90 (124,5)	.85 (21,6)
SAE 152-4 (SAE-D)	13.80 (350,5)	10.54 (267,7)	5.30 (134,6)	.89 (22,6)

NOTE: See page 16 for shaft information.  
See pages 45-54 for rear drive information.

**P6-P7-P8V, D, P Dimensions (Less Controls)**

**Hydrostatic Transmission Piston Pumps  
GOLD CUP® Series - Open & Closed Circuits**

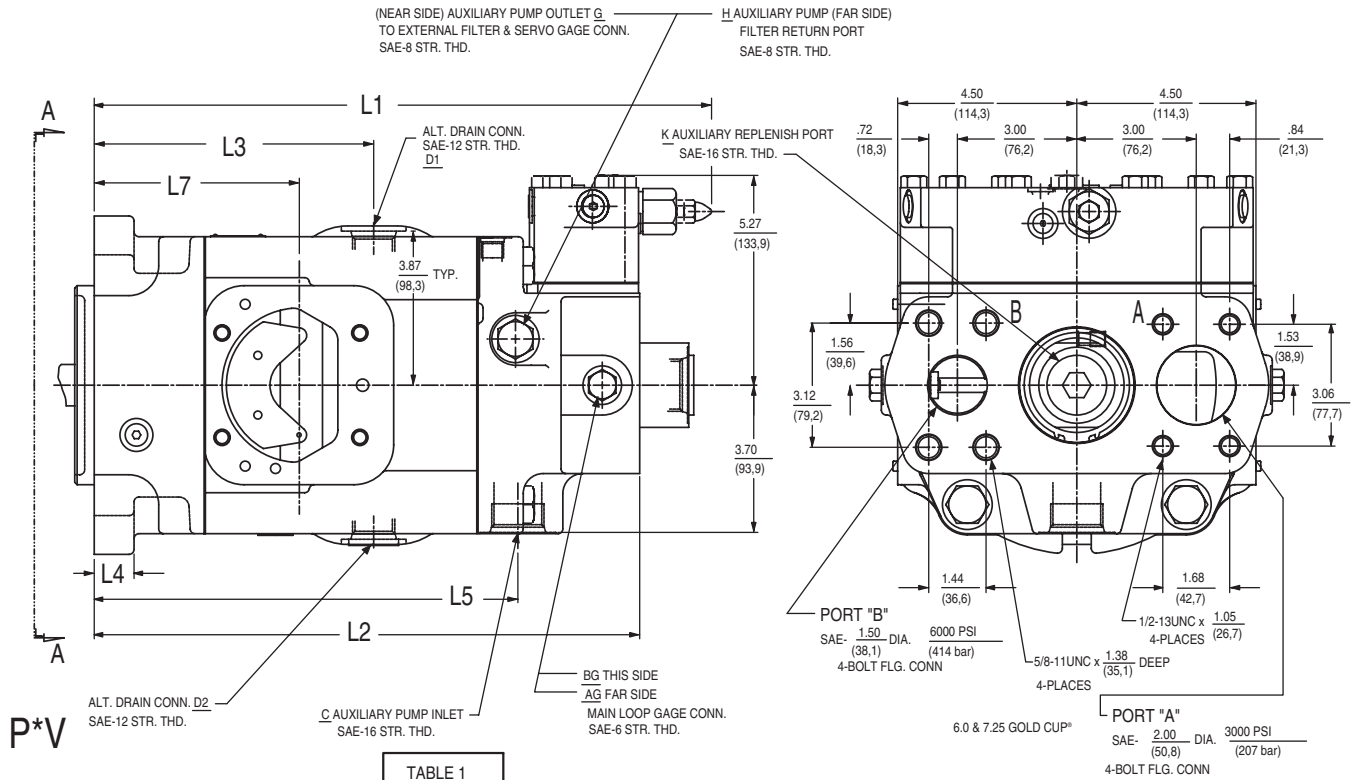
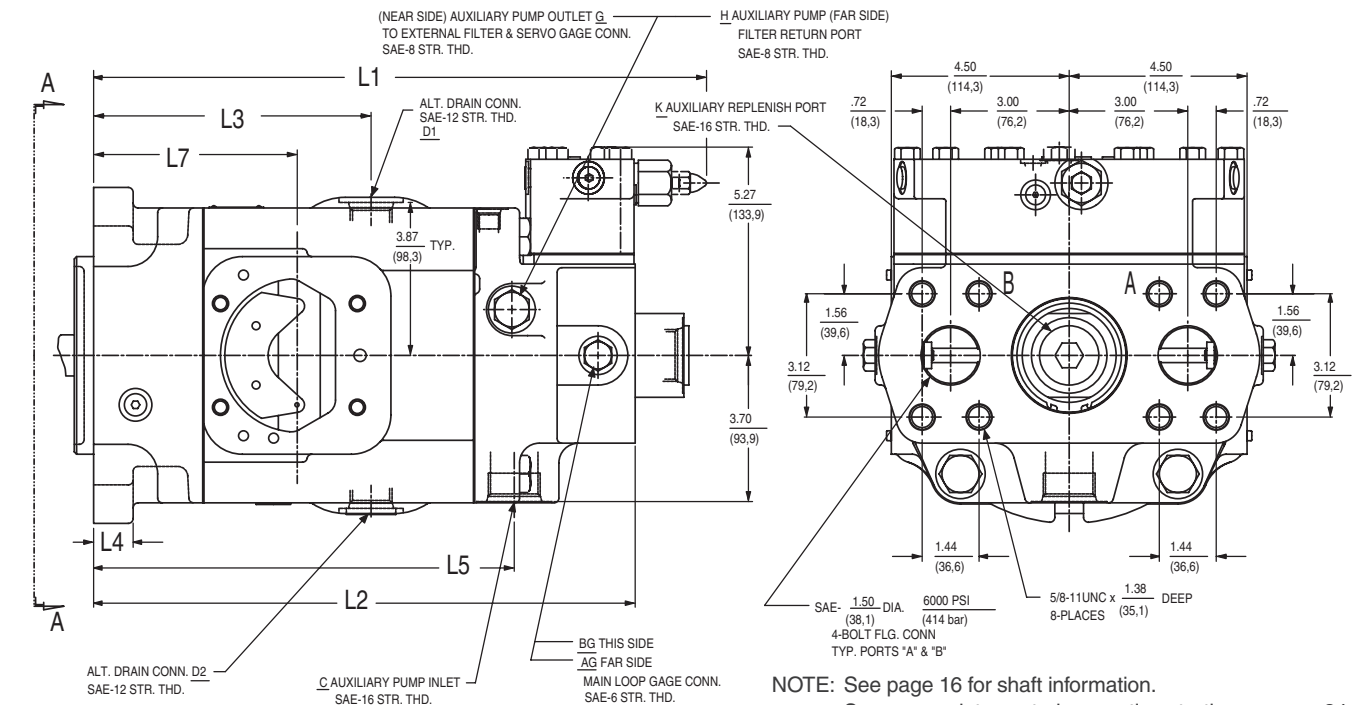

TABLE 1

MOUNTING	L1	L2	L3	L4	L5	L7
SAE 127-2 (SAE-C)	15.51 (393,9)	13.70 (348,0)	7.02 (178,3)	1.00 (25,4)	10.64 (270,3)	5.15 (130,9)
SAE 152-4 (SAE-D)	16.85 (427,9)	15.04 (382,1)	8.36 (212,3)	.86 (21,8)	11.98 (304,3)	6.49 (164,8)

**P\*D & P\*P**



NOTE: See page 16 for shaft information.  
See appropriate controls mounting starting on page 34.



**P6-P7-P8X, R Dimensions (Less Controls)**

**Hydrostatic Transmission Piston Pumps  
GOLD CUP® Series - Open & Closed Circuits**

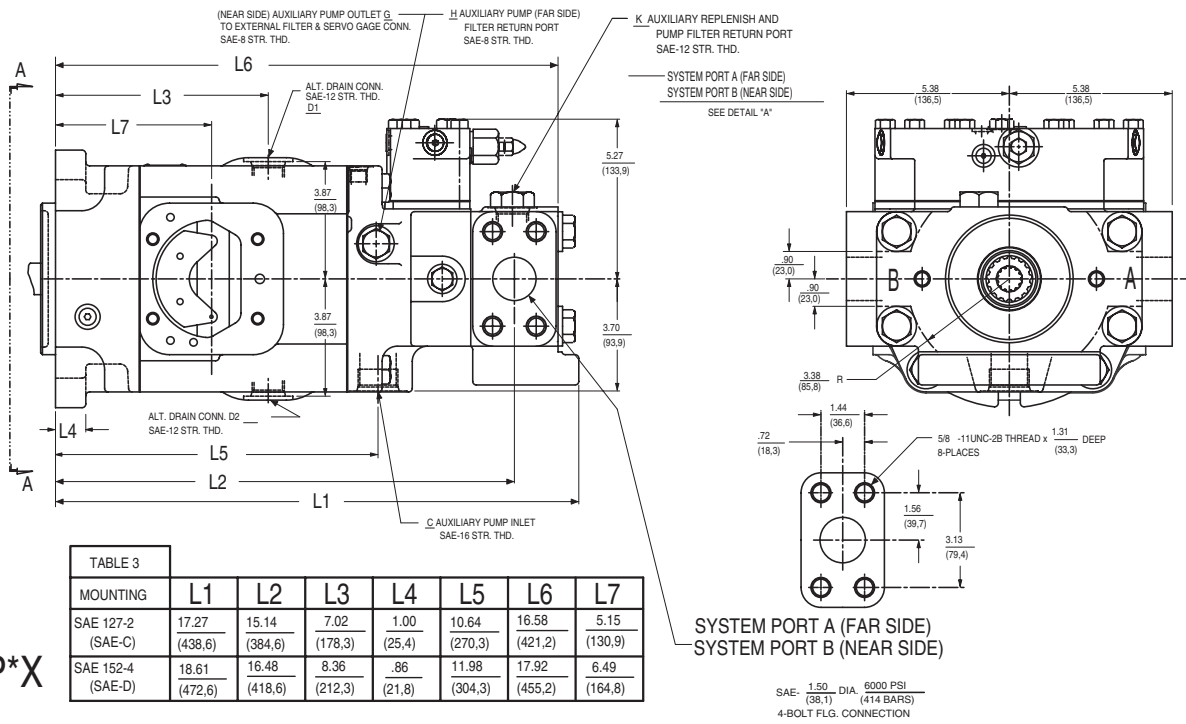

TABLE 3							
MOUNTING	L1	L2	L3	L4	L5	L6	L7
SAE 127-2 (SAE-C)	17.27 (438,6)	15.14 (384,6)	7.02 (178,3)	1.00 (25,4)	10.64 (270,3)	16.58 (421,2)	5.15 (130,9)
SAE 152-4 (SAE-D)	18.61 (472,6)	16.48 (418,6)	8.36 (212,3)	.86 (21,8)	11.98 (304,3)	17.92 (455,2)	6.49 (164,8)

P\*X

P\*R

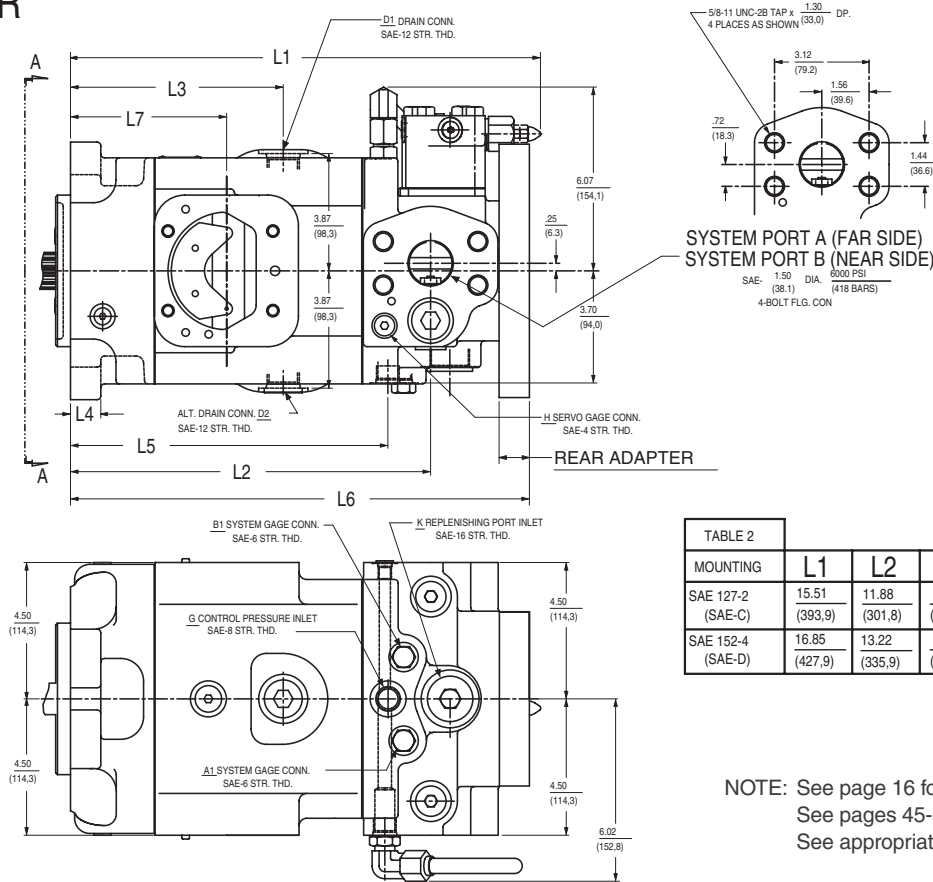
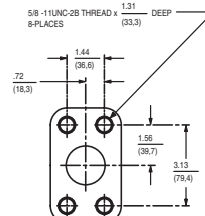
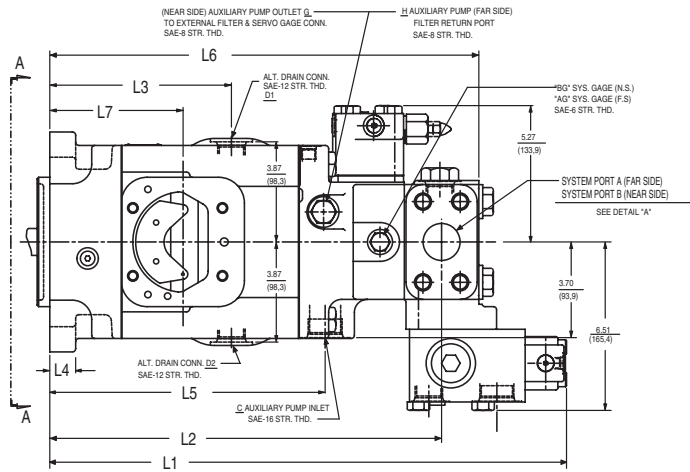

TABLE 2							
MOUNTING	L1	L2	L3	L4	L5	L6	L7
SAE 127-2 (SAE-C)	15.51 (393,9)	11.88 (301,8)	7.02 (178,3)	1.00 (25,4)	10.64 (270,3)	15.14 (384,6)	5.15 (130,9)
SAE 152-4 (SAE-D)	16.85 (427,9)	13.22 (335,9)	8.36 (212,3)	.86 (21,8)	11.98 (304,3)	16.48 (418,7)	6.49 (164,8)

NOTE: See page 16 for shaft information.  
See pages 45-54 for rear drive information.  
See appropriate controls mounting starting on page 34.

HY28-2667-01/GC/NA,EU  
**P6-P7-P8S, L Dimensions (Less Controls)**

Hydrostatic Transmission Piston Pumps  
**GOLD CUP® Series - Open & Closed Circuits**



**DETAIL "A"**  
 SYSTEM PORTS A & B  
 SAE: 1.50" DIA. 6000 PSI (38.1" (414 BARS))  
 4-BOLT FLG. CONNECTION

**TABLE 5**

MOUNTING	L1	L2	L3	L4	L5	L6	L7
SAE 127-2 (SAE-C)	19.97 (507.3)	15.14 (384.6)	7.02 (178.3)	1.00 (25.4)	10.64 (270.3)	16.58 (421.2)	5.15 (130.9)
SAE 152-4 (SAE-D)	21.31 (541.3)	16.48 (418.6)	8.36 (212.3)	.86 (21.8)	11.98 (304.3)	17.92 (455.2)	6.49 (164.8)

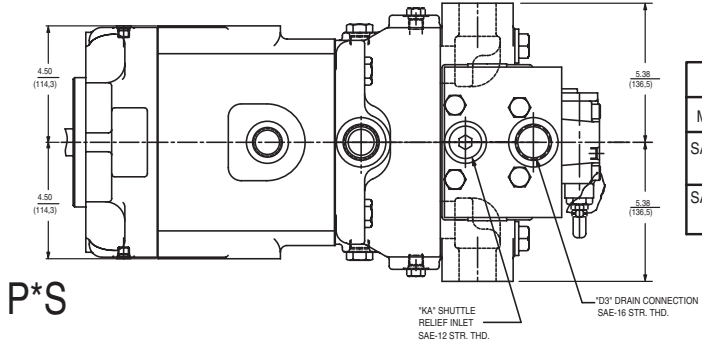

**P\*S**

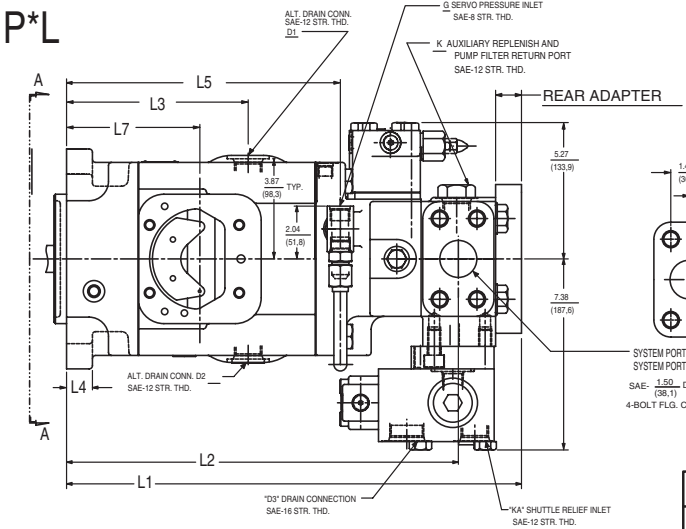

**TABLE 4**

MOUNTING	L1	L2	L3	L4	L5	L6	L7
SAE 127-2 (SAE-C)	17.58 (446.6)	15.14 (384.6)	7.02 (178.3)	1.00 (25.4)	10.58 (268.8)	16.58 (421.2)	5.15 (130.9)
SAE 152-4 (SAE-D)	18.92 (480.6)	16.48 (418.6)	8.36 (212.3)	.86 (21.8)	11.92 (302.8)	17.92 (455.2)	6.49 (164.8)

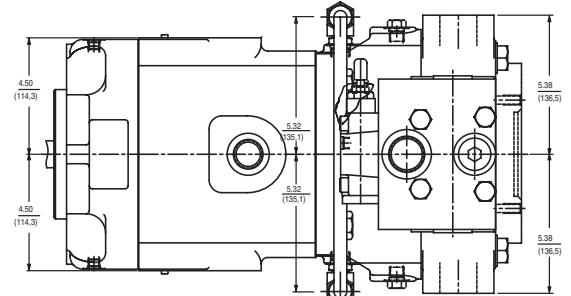

NOTE: See page 16 for shaft information.  
 See pages 45-54 for rear drive information.  
 See appropriate controls mounting starting on page 34.



**M\*F & M\*G**

MOUNTING	L1	L2	L3	L4
SAE 127-2 (SAE-C)	11.19 (284,2)	11.06 (280,9)	4.90 (124,5)	.85 (21,6)
SAE 152-4 (SAE-D)	11.59 (294,3)	11.46 (291,1)	5.30 (134,6)	.89 (22,6)

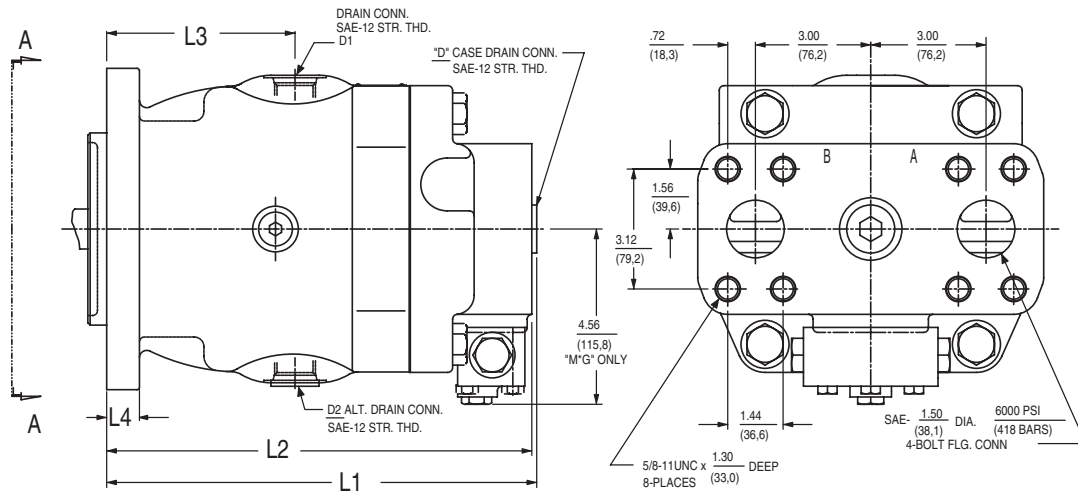

**M\*M & M\*N**

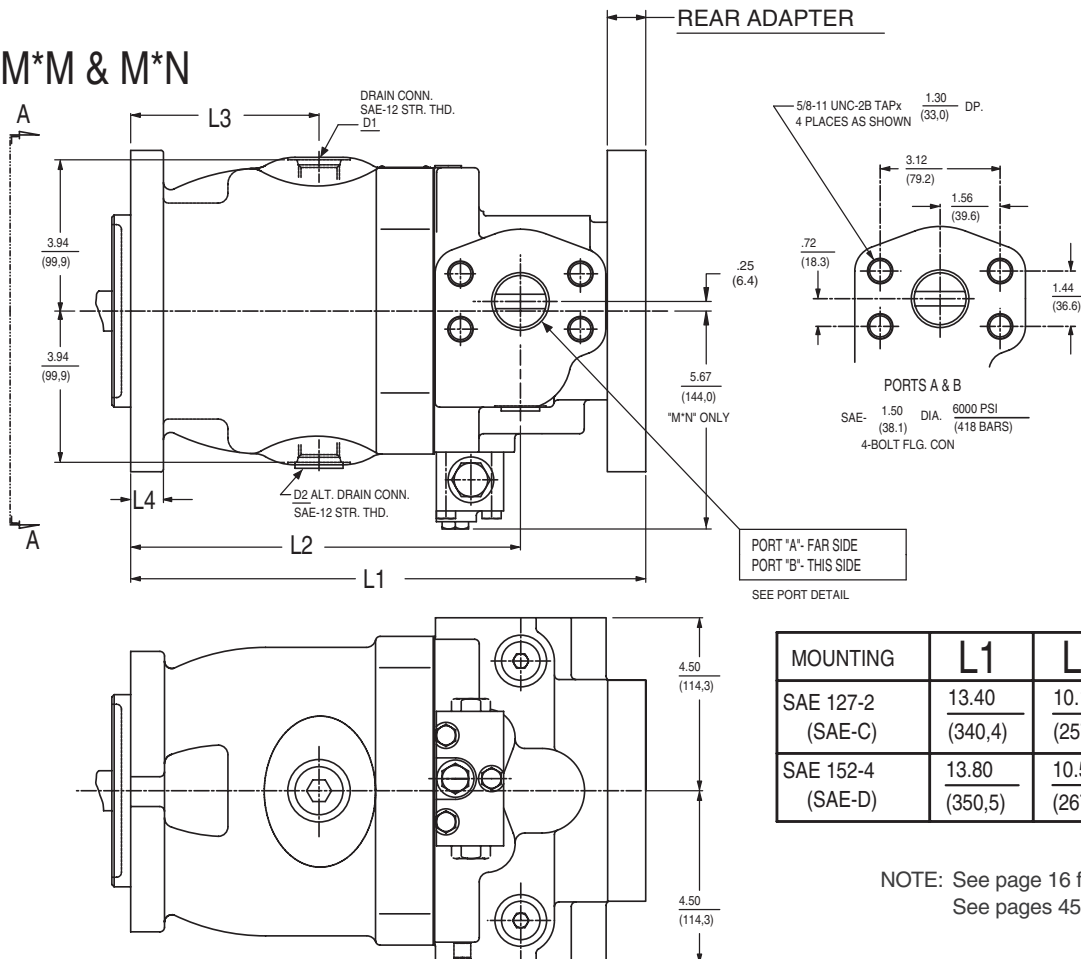

MOUNTING	L1	L2	L3	L4
SAE 127-2 (SAE-C)	13.40 (340,4)	10.14 (257,6)	4.90 (124,5)	.85 (21,6)
SAE 152-4 (SAE-D)	13.80 (350,5)	10.54 (267,7)	5.30 (134,6)	.89 (22,6)

NOTE: See page 16 for shaft information.  
 See pages 45-54 for rear drive information.

**M\*H & M\*V**

TABLE 14						
MOUNTING	L1	L2	L3	L4	L5	L7
SAE 127-2 (SAE-C)	13.16 (334,3)	12.80 (325,1)	7.02 (178,3)	1.00 (25,4)	10.58 (268,8)	5.15 (130,9)
SAE 152-4 (SAE-D)	14.50 (368,3)	14.14 (359,2)	8.36 (212,3)	.86 (21,8)	11.92 (302,8)	6.49 (164,8)

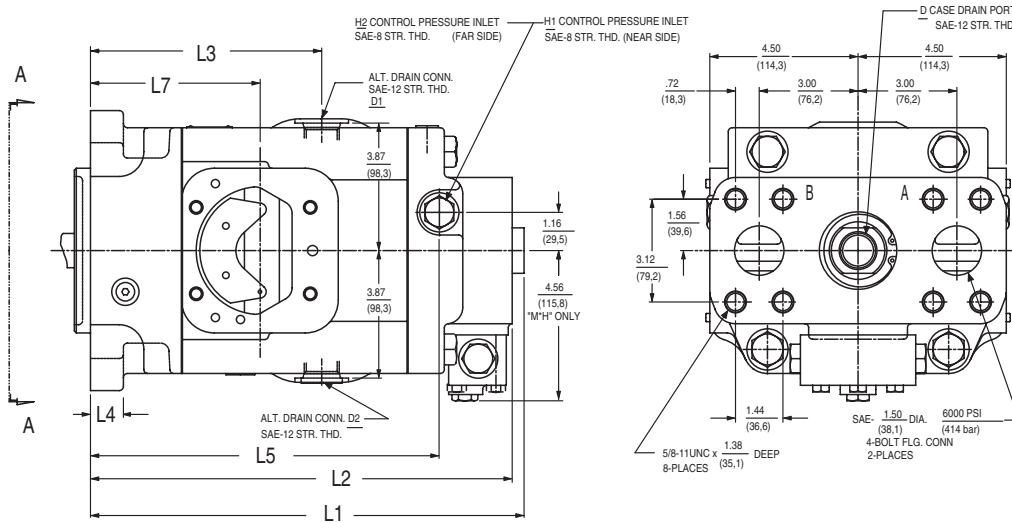

**M\*R & M\*L**

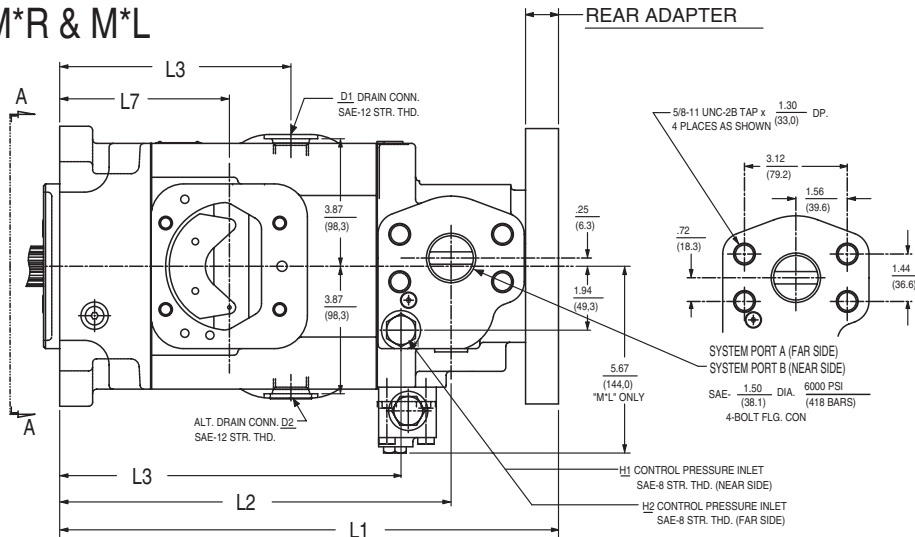

TABLE 13						
MOUNTING	L1	L2	L3	L4	L5	L7
SAE 127-2 (SAE-C)	15.14 (384,6)	11.88 (301,8)	7.02 (178,3)	1.00 (25,4)	10.36 (263,1)	5.15 (130,9)
SAE 152-4 (SAE-D)	16.48 (418,7)	13.22 (335,9)	8.36 (212,3)	.86 (21,8)	11.70 (297,2)	6.49 (164,8)

NOTE: See page 16 for shaft information.  
 See pages 45-54 for rear drive information.  
 See appropriate controls mounting starting on page 34.





M\*F, M\*G, M\*H, M\*V, P\*S, P\*X, P\*D, P\*P, P\*V & P\*F M\*R, M\*L, M\*M, M\*N, P\*L & P\*R

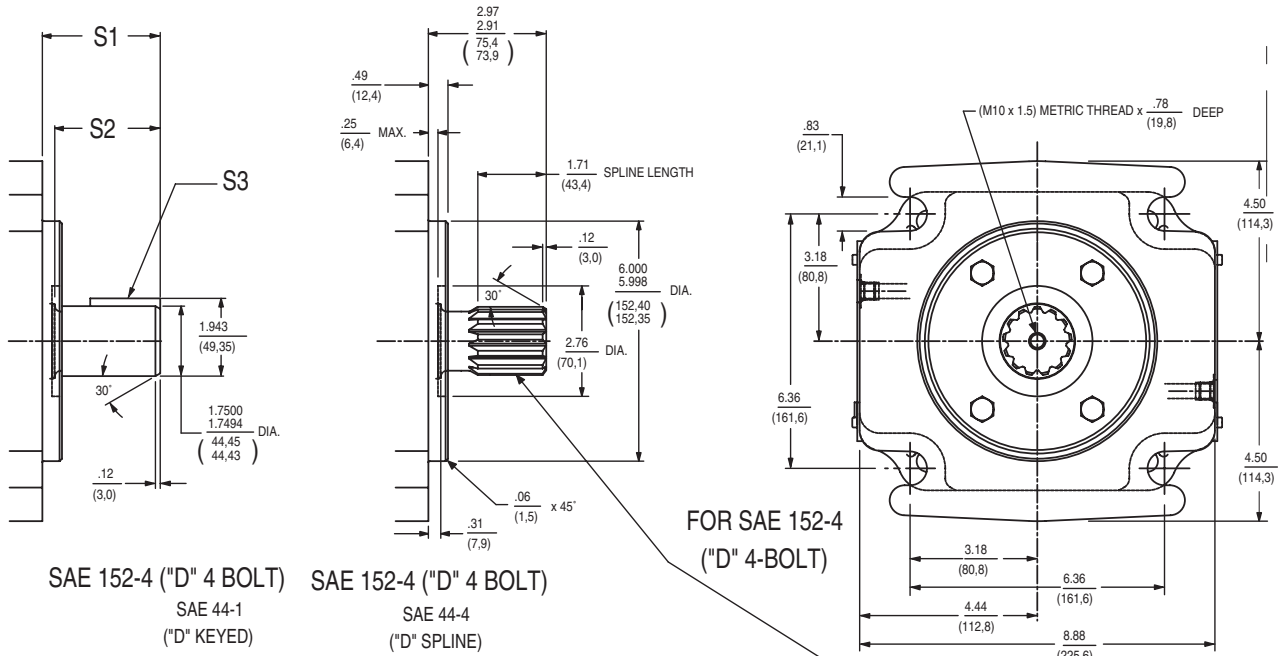

SAE 152-4 ("D" 4 BOLT) SAE 152-4 ("D" 4 BOLT)  
 SAE 44-1 ("D" KEYED) SAE 44-4 ("D" SPLINE)

FOR SAE 152-4  
 ("D" 4-BOLT)

SHAFT DESIGNATION PUMP MODEL CODE	SHAFT	S1	S2	S3	
04	SAE 44-1 (SAE-D Key)	2.97/2.91 (75,4/73,9)	2.64 (67,0)	.438/.437 (11,12/11,10)	SQ. KEY x 1.75 (44,4)

SHAFT DESIGNATION PUMP MODEL CODE	SAE INVOLUTE SPLINE J498-B 1969 EXTERNAL CLASS 1 FLAT ROOT 8/16 DIA. PITCH 30° PRESSURE ANGLE 13 TEETH 1.7210-1.7160 MAJOR DIA (43,713/43,586)	SIDE FIT
05		

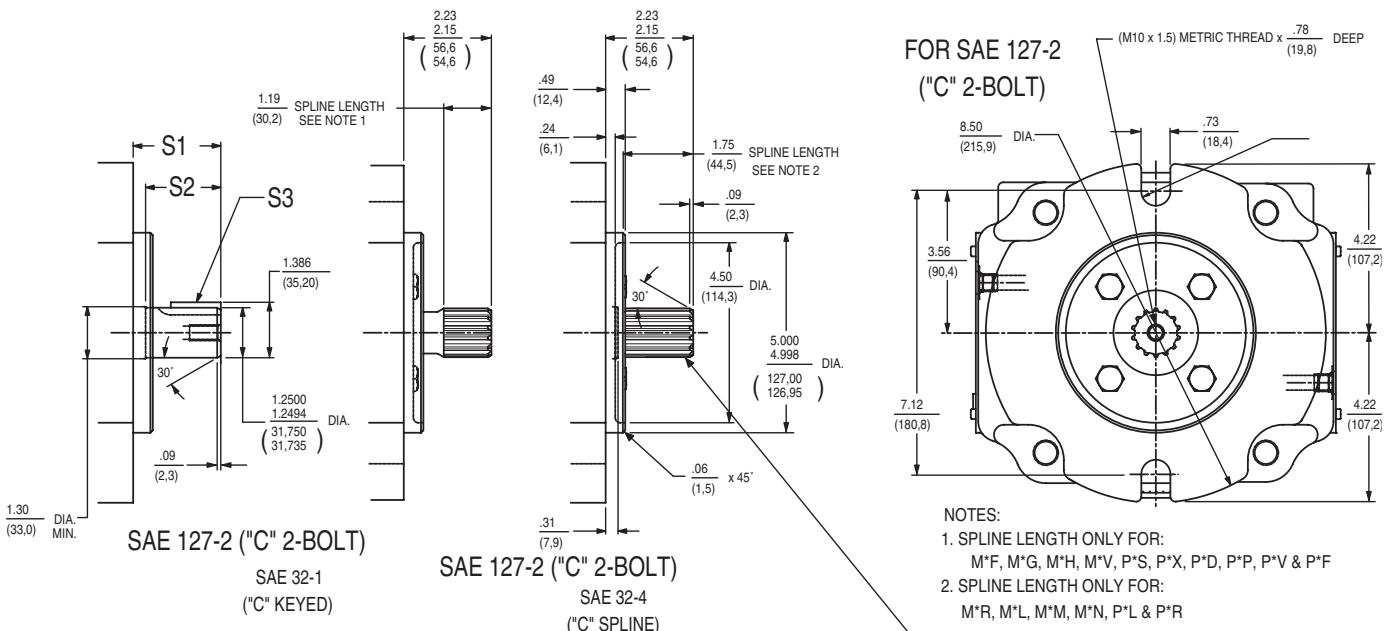

SAE 127-2 ("C" 2-BOLT) SAE 127-2 ("C" 2-BOLT)  
 SAE 32-1 ("C" KEYED) SAE 32-4 ("C" SPLINE)

FOR SAE 127-2  
 ("C" 2-BOLT)

- NOTES:  
 1. SPLINE LENGTH ONLY FOR:  
 M\*F, M\*G, M\*H, M\*V, P\*S, P\*X, P\*D, P\*P, P\*V & P\*F  
 2. SPLINE LENGTH ONLY FOR:  
 M\*R, M\*L, M\*M, M\*N, P\*L & P\*R

SHAFT DESIGNATION PUMP MODEL CODE	SHAFT	S1	S2	S3	
02 or 07	SAE 32-1 (SAE-C)	2.23/2.15 (56,6/54,6)	1.88 (47,8)	.312/.310 (7,92/7,87)	1.25/1.22 (31,8/31,0)
09 or 10	SAE 32-1 LONG (SAE-C)	3.36/3.28 (85,3/83,3)	3.01 (76,4)	.312/.310 (7,92/7,87)	SQ. KEY x LG. 2.38/2.35 (60,4/59,7)

SHAFT DESIGNATION PUMP MODEL CODE	SAE INVOLUTE SPLINE J498-B 1969 EXTERNAL CLASS 1 FLAT ROOT 12/24 DIA. PITCH 30° PRESSURE ANGLE 14 TEETH 1.2293-1.2243 MAJOR DIA (31,224/31,097)	SIDE FIT
03 or 08		

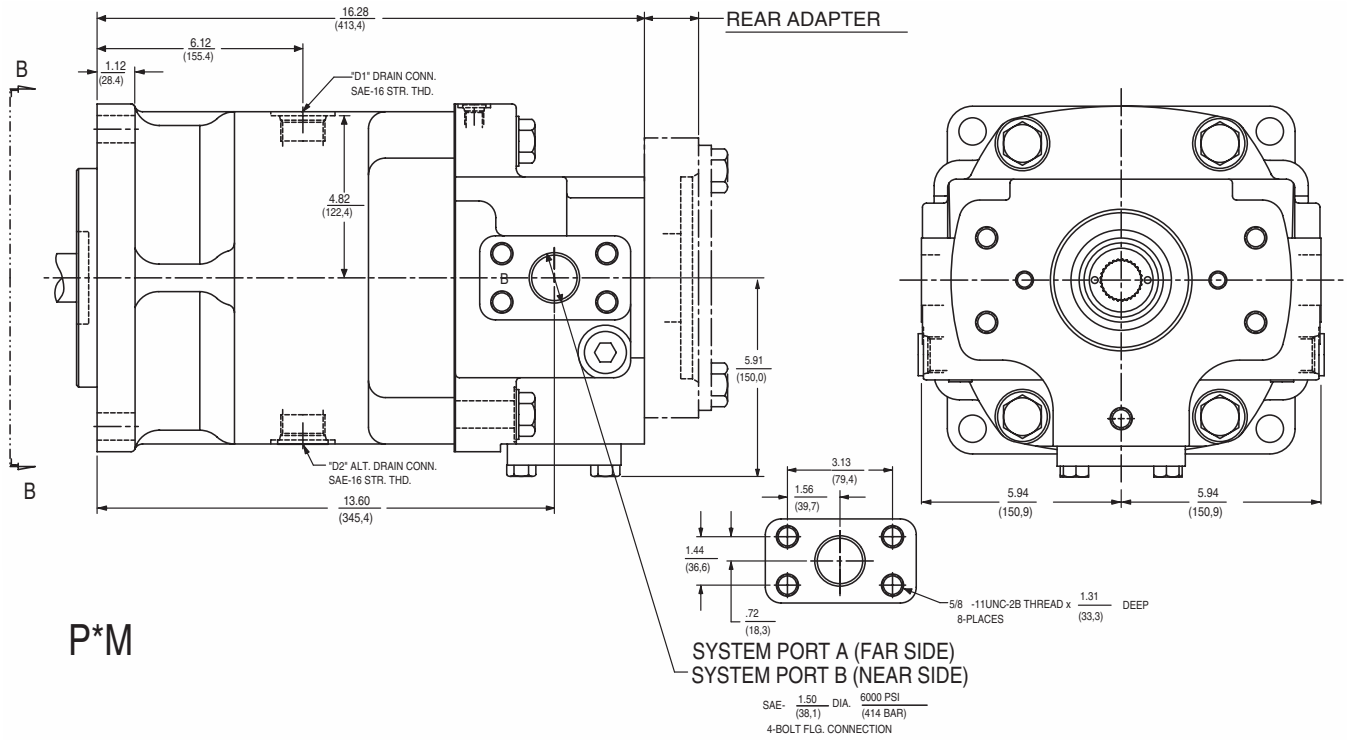

**P\*F**

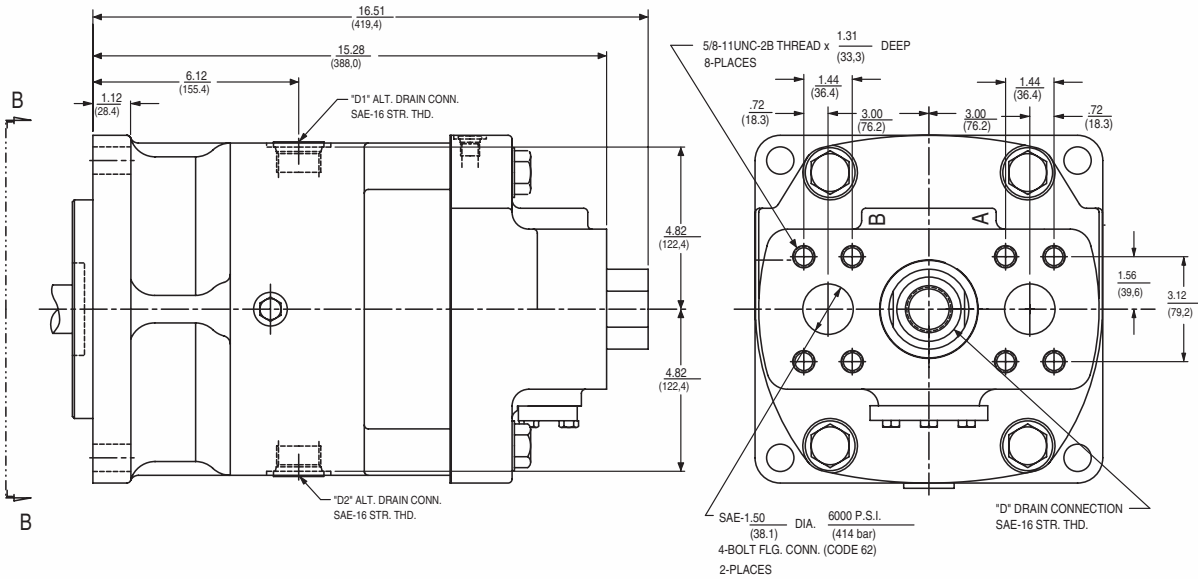

NOTE: See page 23 for shaft information.  
 See pages 45-54 for rear drive information.

**P11-P14 P, V Dimensions (Less Controls)**

**Hydrostatic Transmission Piston Pumps  
GOLD CUP® Series - Open & Closed Circuits**

SAE-1.50 DIA. 6000 P.S.I.  
(38.1) (415 bar)  
4-BOLT FLG. CONN. (CODE 62)  
TYPICAL 2-PLACES

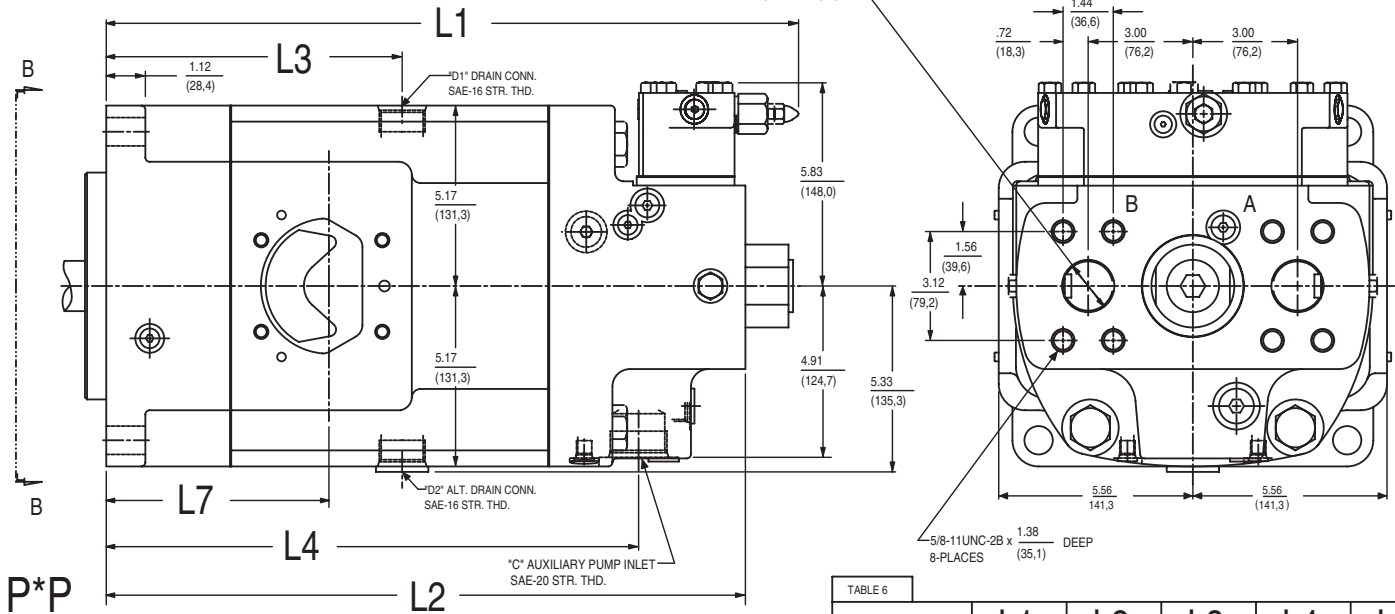

PUMP	L1	L2	L3	L4	L7
P11P, P14P & P11V, P14V	19.83 (503,8)	18.31 (465,2)	8.48 (215,3)	15.25 (387,4)	6.38 (162,0)

**P\*V**

SAE-1.50 DIA. 6000 P.S.I.  
(38.1) (415 bar)  
4-BOLT FLG. CONN. (CODE 62)

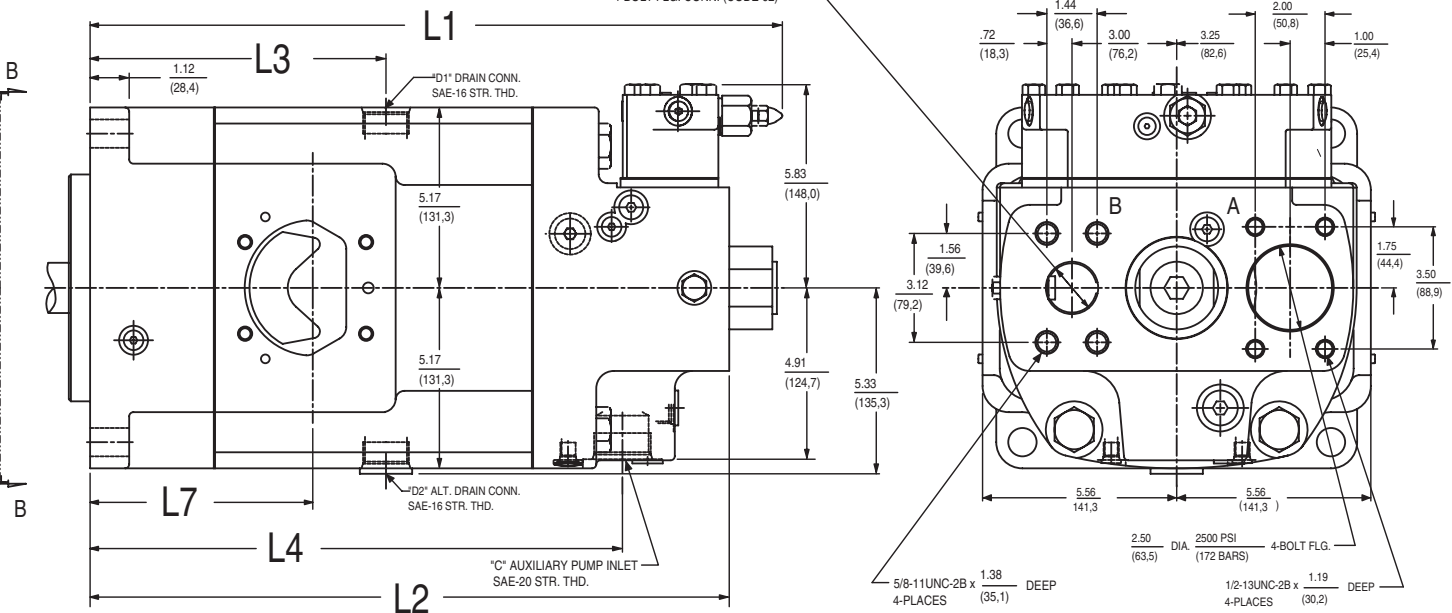

NOTE: See page 23 for shaft information.  
See appropriate controls mounting starting on page 34.

**P11-P14 S, X Dimensions (Less Controls)**

**Hydrostatic Transmission Piston Pumps  
GOLD CUP® Series - Open & Closed Circuits**

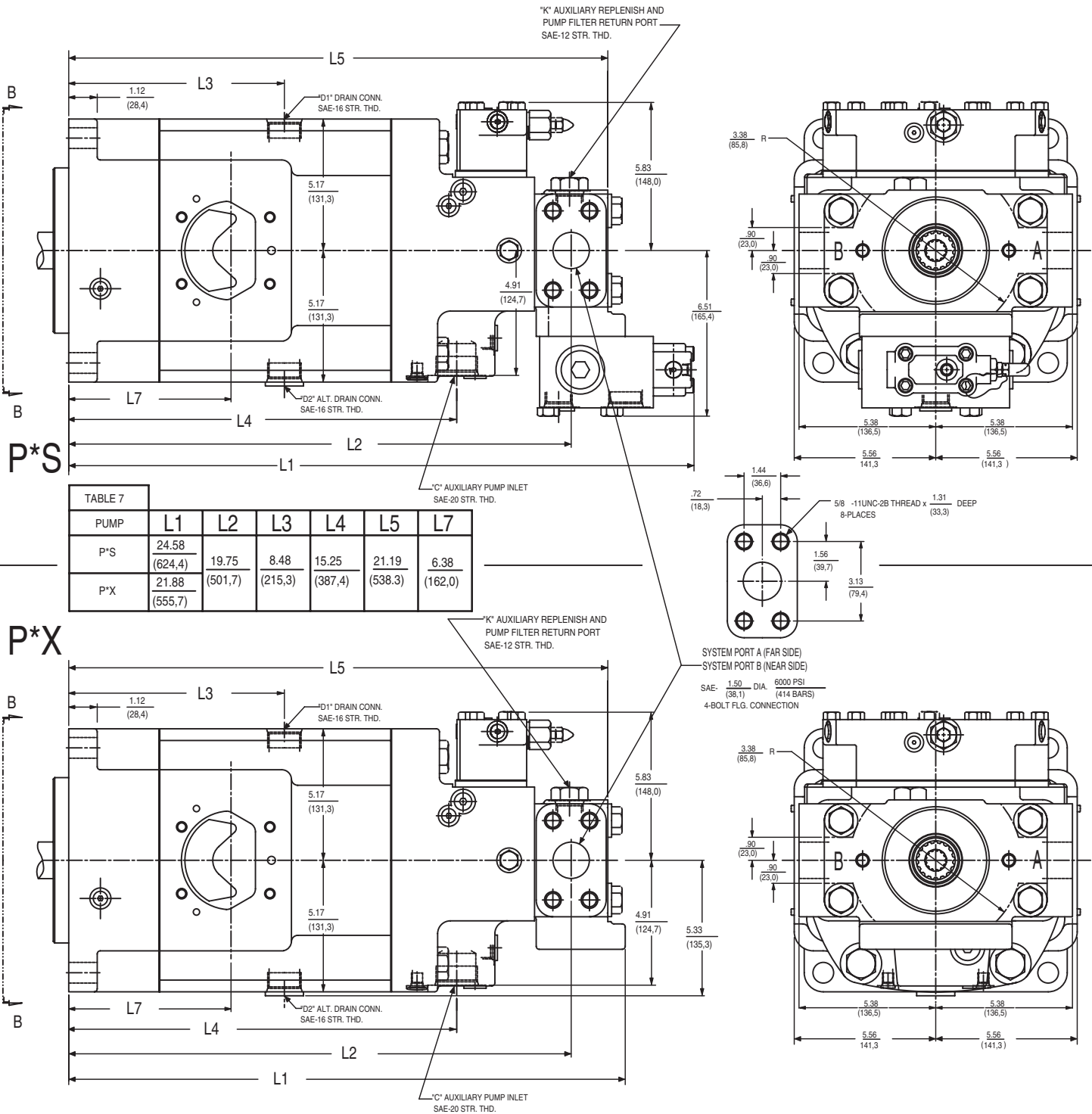

NOTE: See page 23 for shaft information.  
 See pages 45-53 for rear drive information.  
 See appropriate controls mounting starting on page 34.

**P\*R & P\*L**

TABLE 8					
PUMP	L1	L2	L3	L4	L7
P*R & P*L	18.31 (465,2)	15.64 (397,1)	8.48 (215,3)	18.31 (465,2)	6.38 (162,0)

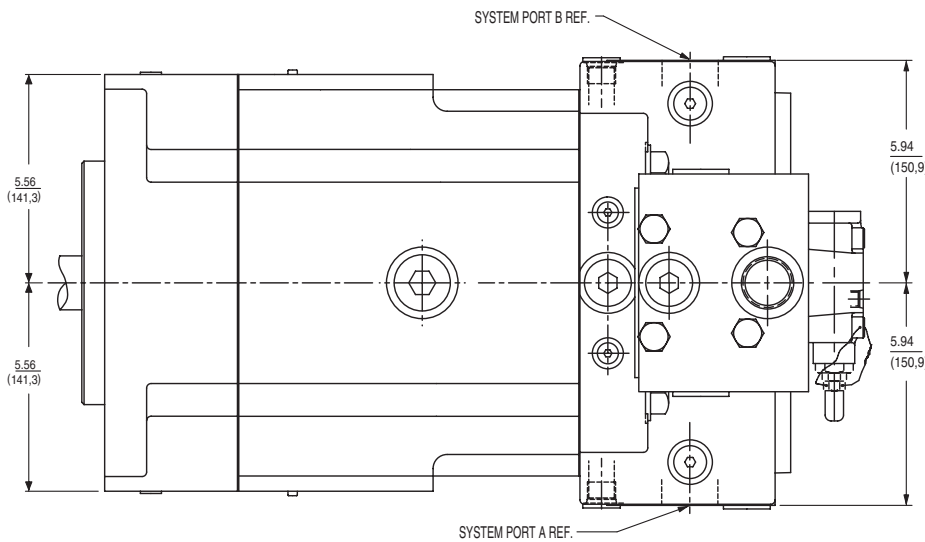
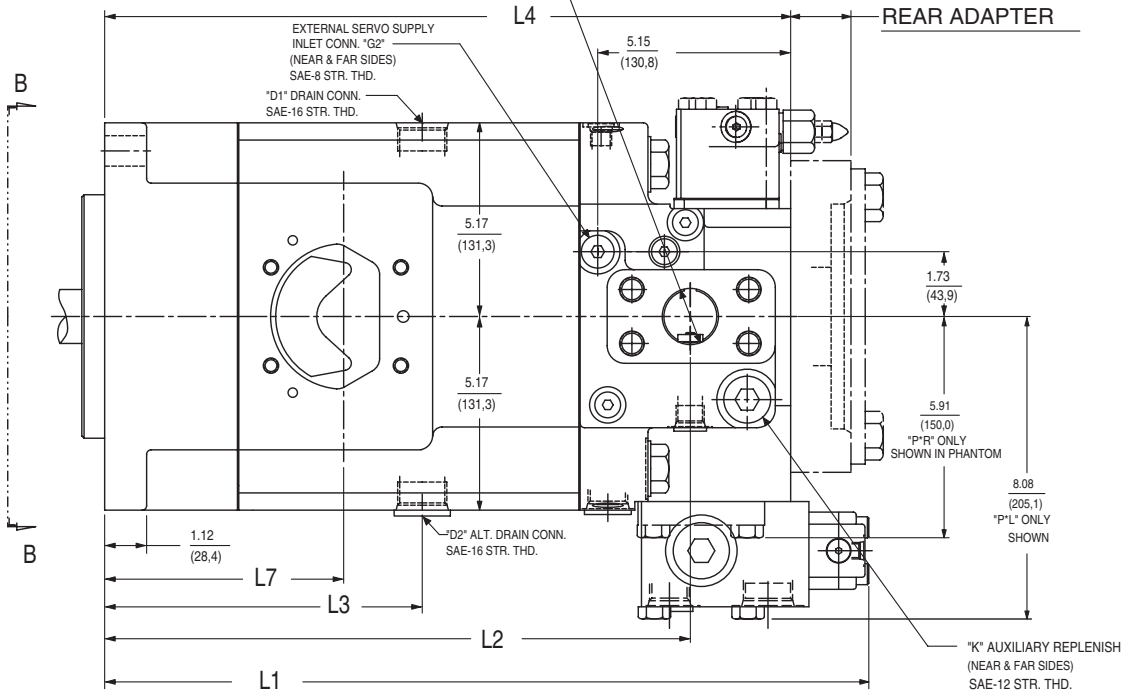
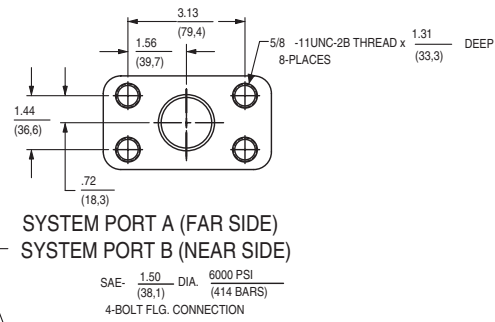

NOTE: See page 23 for shaft information.  
 See pages 45-53 for rear drive information.  
 See appropriate controls mounting starting on page 34.

11-14 MOTOR DIMENSIONS

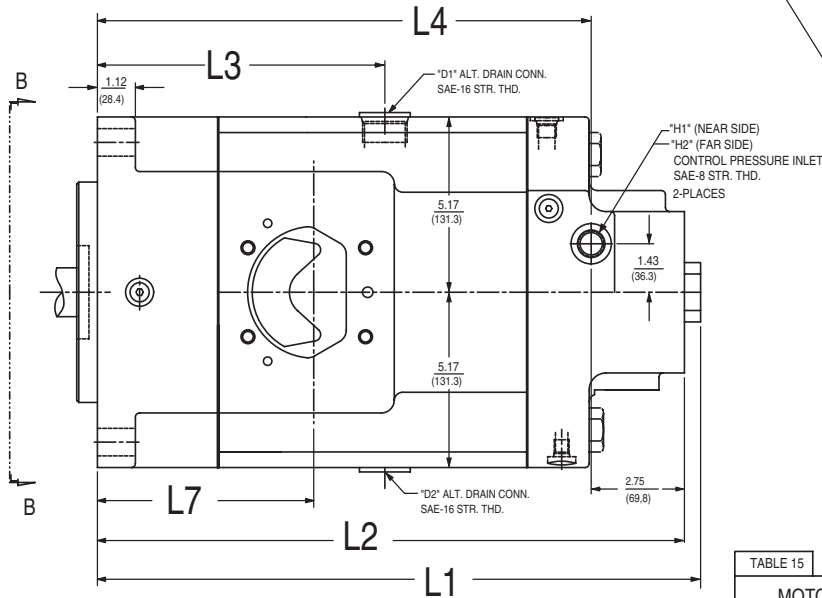

M\*H & M\*V

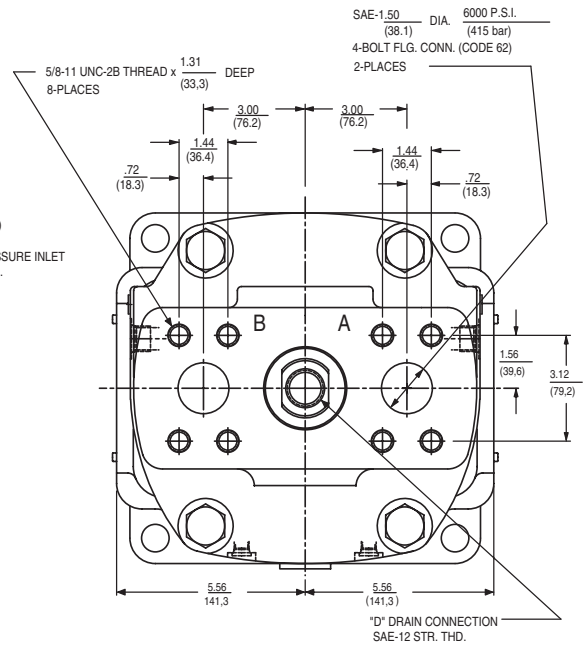
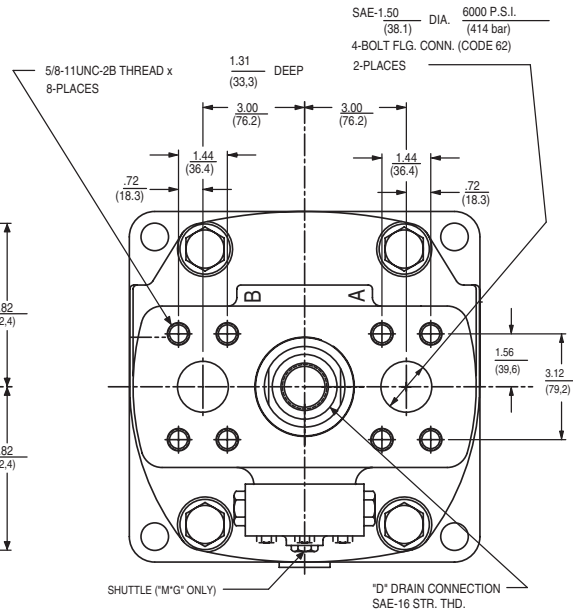
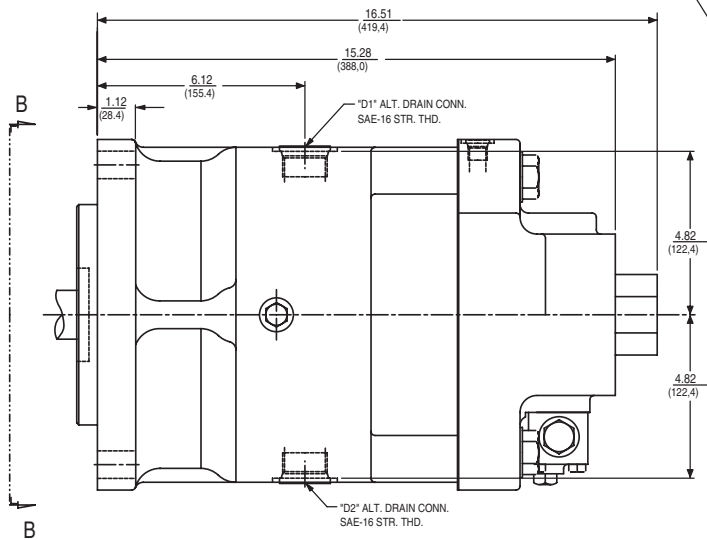

TABLE 15

MOTOR	L1	L2	L3	L4	L7
M11H, M11V & M14H, M14V	17.79 (451.9)	17.32 (439.9)	8.48 (215.3)	14.56 (369.9)	6.38 (162.0)

M\*F & M\*G



NOTE: See page 23 for shaft information.  
See appropriate controls mounting starting on page 34.

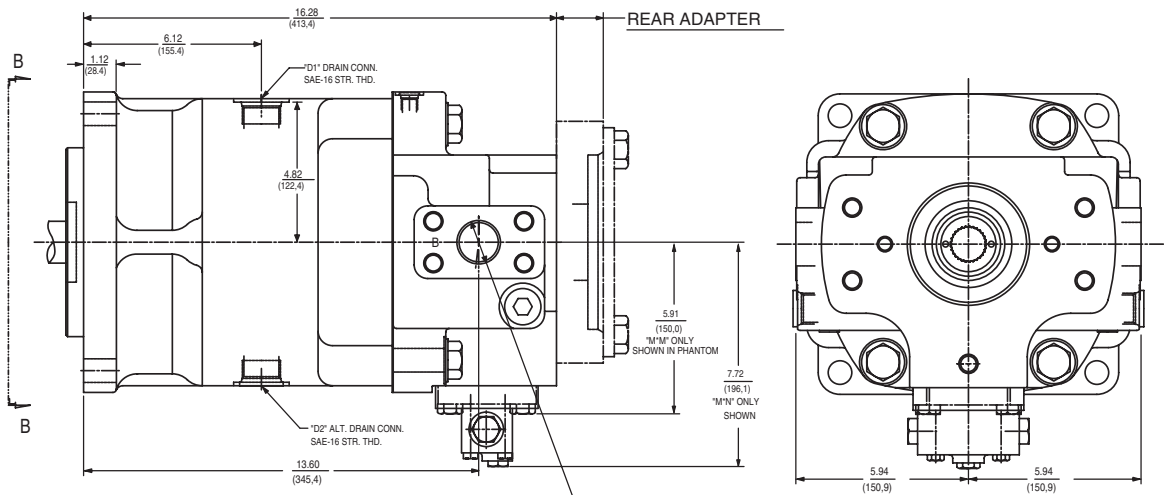

M\*M & M\*N

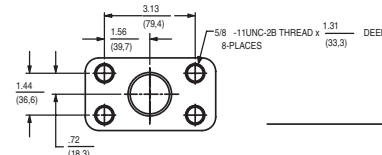

SYSTEM PORT A (FAR SIDE)  
SYSTEM PORT B (NEAR SIDE)

SAE: 1.50 DIA. 6000 PSI  
(38.1) (414 BARS)  
4-BOLT FLG. CONNECTION

M\*R & M\*L

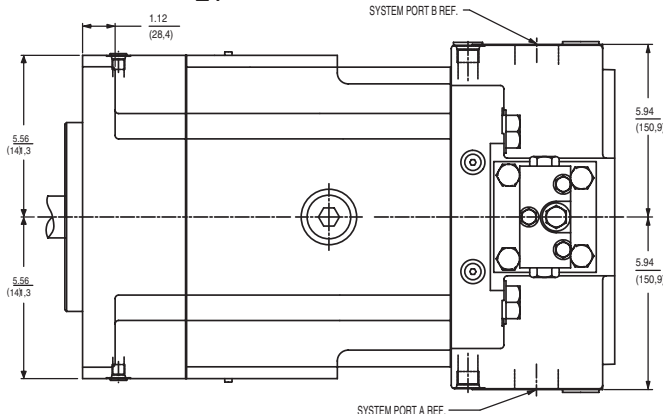
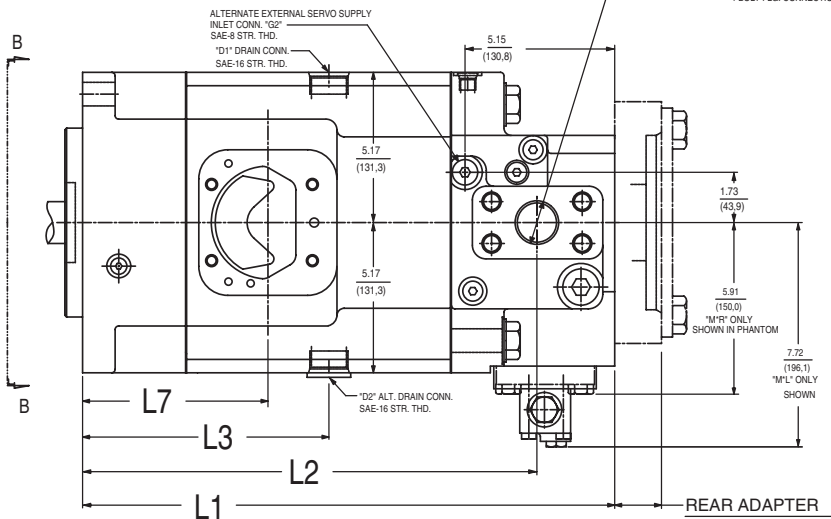

MOTOR	L1	L2	L3	L4	L7
M11R, M11L & M14R, M14L	18.31 (465,2)	15.64 (397,1)	8.48 (215,3)	14.56 (369,9)	6.38 (162,0)

NOTE: See page 23 for shaft information.  
See pages 45-54 for rear drive information.  
See appropriate controls mounting starting on page 34.

M\*F, M\*G, M\*H, M\*V, P\*S, P\*X, P\*P, P\*V & P\*F M\*R, M\*L, M\*M, M\*N, P\*L & P\*R

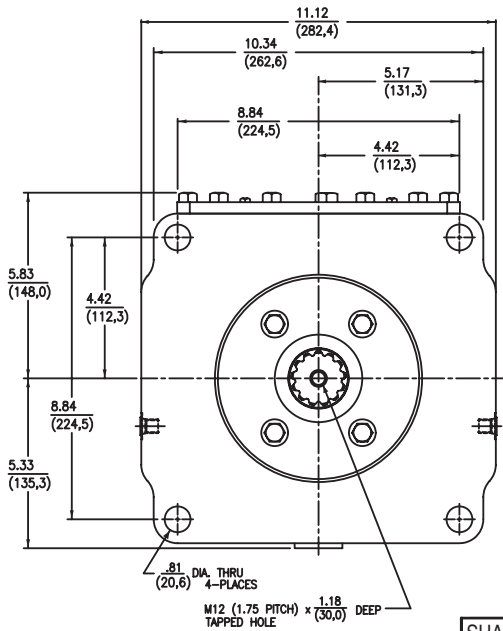

**VIEW B-B**

NOTES:

- SPLINE LENGTH AND NECK ONLY FOR:  
M\*F, M\*G, M\*H, M\*V, P\*S, P\*X, P\*P, P\*V & P\*F
- SPLINE LENGTH ONLY FOR:  
M\*R, M\*L, M\*M, M\*N, P\*L & P\*R

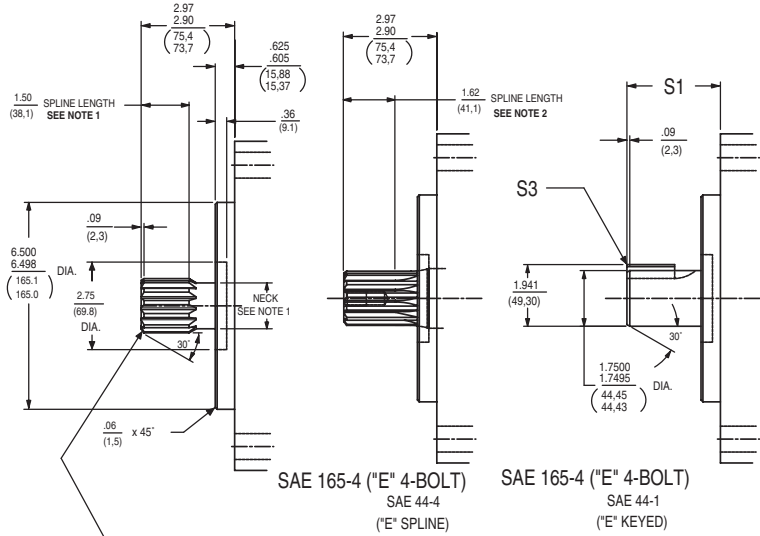

SHAFT DESIGNATION PUMP MODEL CODE	SAE INVOLUTE SPLINE DATA J498B 1969 FLAT ROOT SIDE FIT EXTERNAL CLASS 1 8/16 PITCH 30° PRESSURE ANGLE 13 TEETH 1.7210-1.7160 MAJOR DIA. (43,713-43,586)	
	03 or 08	

SHAFT DESIGNATION PUMP MODEL CODE	SHAFT	S1	S3
02 or 07	SAE 44-1 (SAE-E)	2.97/2.90 (75,4/73,7)	.437/.435 (11,10/11.05) SQ. KEY x LG. 1.50 (38,1)
09 or 10	SAE 44-1 LONG (SAE-E)	3.97/3.90 (100,8/99,1)	.437/.435 (11,10/11.05) SQ. KEY x LG. 2.50 (63,5)



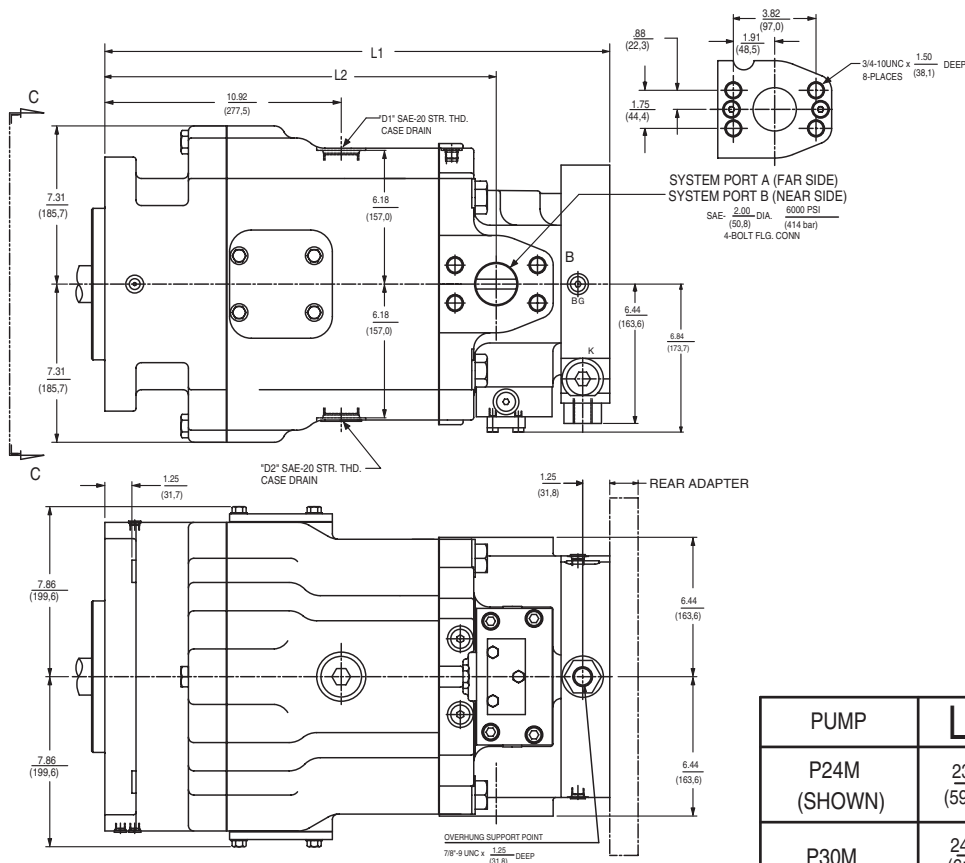

**P\*M**

PUMP	L1	L2
P24M (SHOWN)	23.33 (592.6)	18.09 (459.4)
P30M	24.33 (618.0)	19.09 (484.8)

**P\*F**

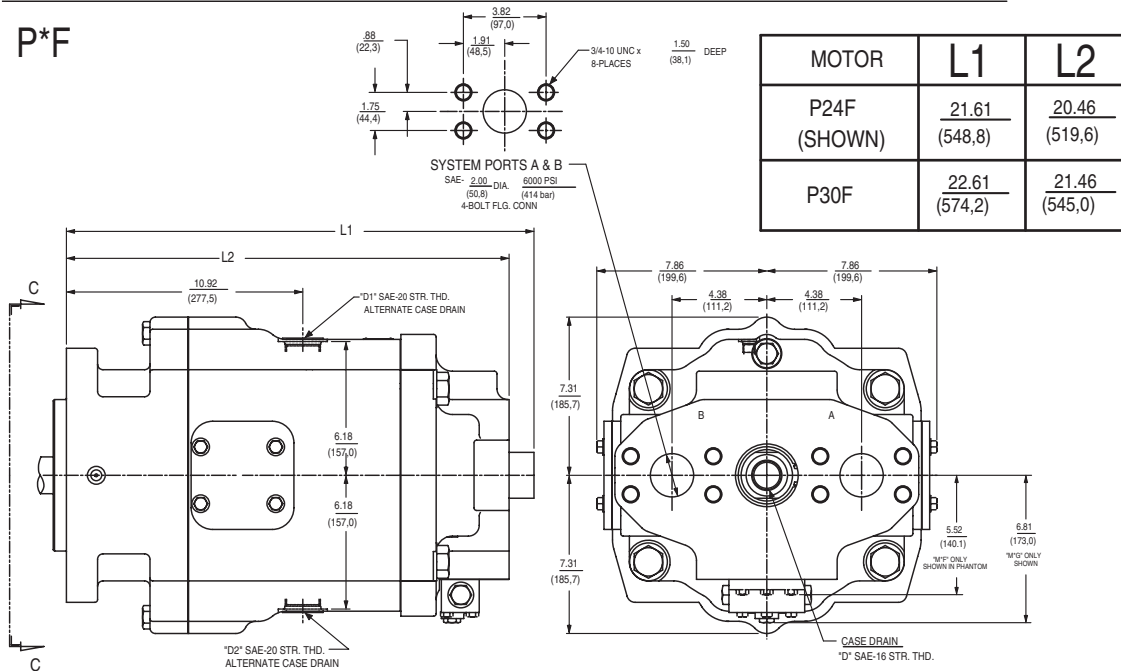

MOTOR	L1	L2
P24F (SHOWN)	21.61 (548.8)	20.46 (519.6)
P30F	22.61 (574.2)	21.46 (545.0)

NOTE: See page 32 for shaft information.

**P24-P30 P Dimensions (Less Controls)**

**Hydrostatic Transmission Piston Pumps  
GOLD CUP® Series - Open & Closed Circuits**

24-30 PUMP DIMENSIONS  
(LESS CONTROLS)

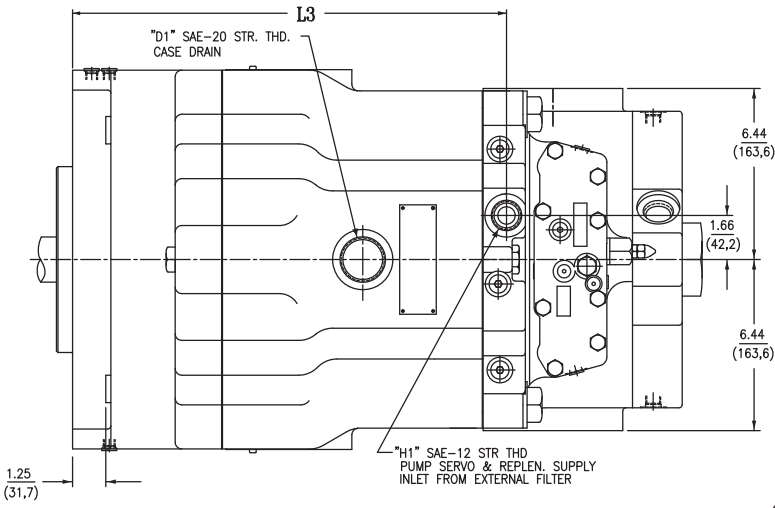

PUMP	L1	L2	L3	L4	L7
P24P (SHOWN)	23.70 (602,1)	18.08 (459,4)	16.34 (414,9)	18.80 (477,4)	8.14 (206,7)
P30P	24.70 (627,5)	19.08 (484,7)	17.34 (440,3)	19.80 (502,8)	

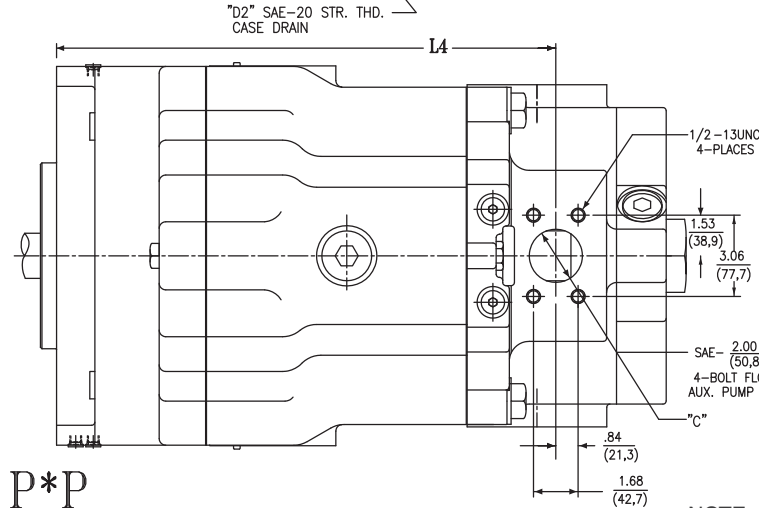
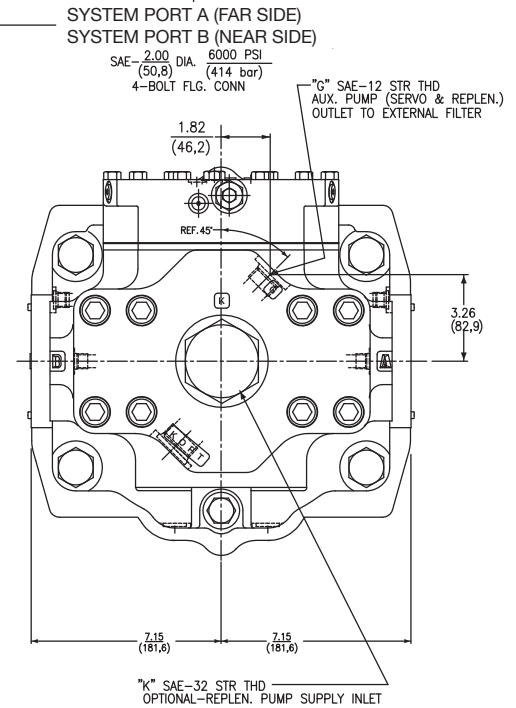
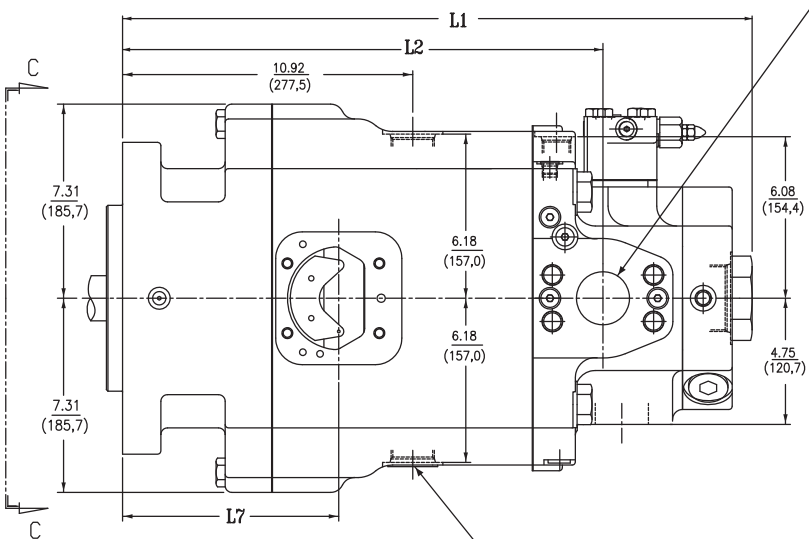
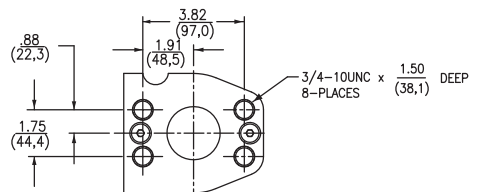

P\*P

NOTE: See page 32 for shaft information.  
See appropriate controls mounting starting on page 34.



**P24-P30 X Dimensions (Less Controls)**

**Hydrostatic Transmission Piston Pumps  
GOLD CUP® Series - Open & Closed Circuits**

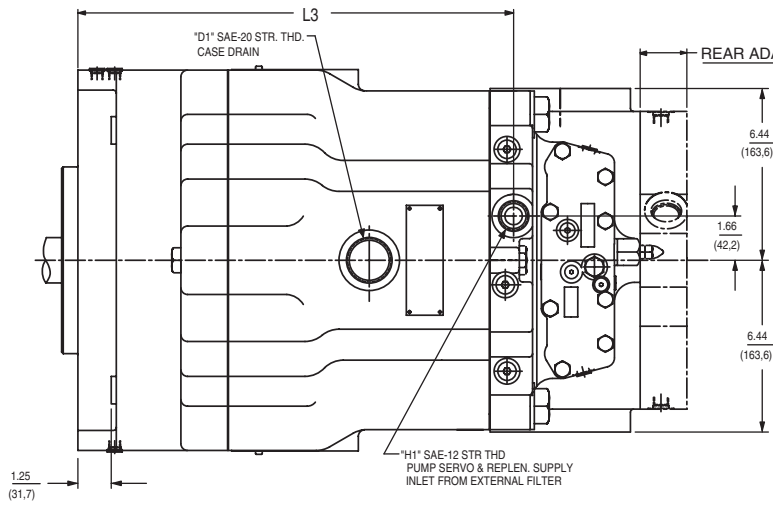
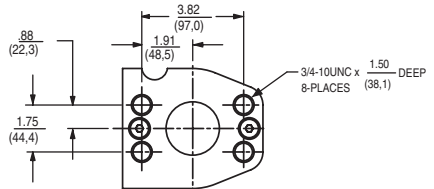
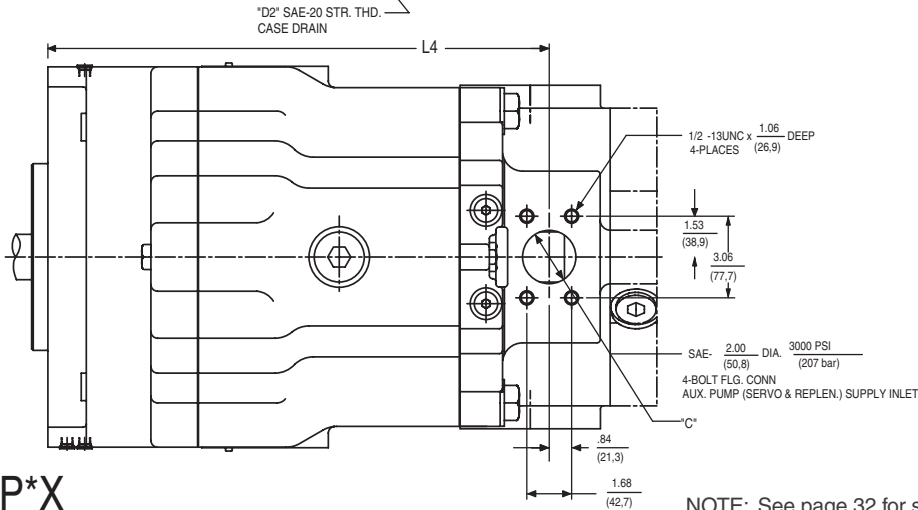
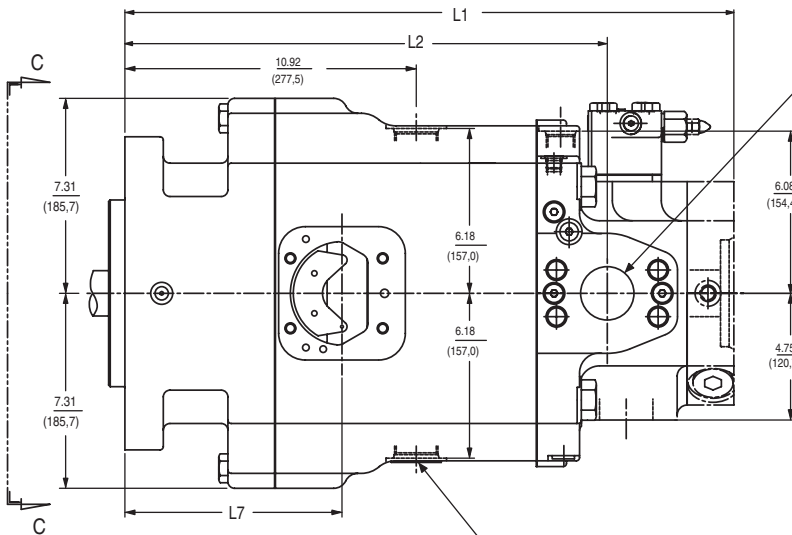
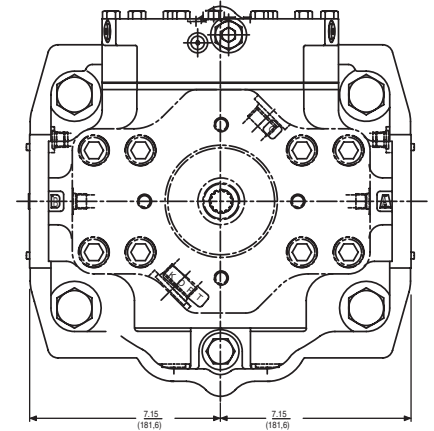

TABLE 11

PUMP	L1	L2	L3	L4	L7
P24X (SHOWN)	22.83 (579.9)	18.08 (459.4)	16.34 (414.9)	18.80 (477.4)	8.14 (206.7)
P30X	23.83 (605.3)	19.08 (484.7)	17.34 (440.3)	19.80 (502.8)	



SYSTEM PORT A (FAR SIDE)  
SYSTEM PORT B (NEAR SIDE)  
SAE- 2.00 DIA. 6000 PSI (50.8) (414 bar)  
4-BOLT FLG. CONN



**P\*X**

NOTE: See page 32 for shaft information.  
See pages 45-53 for rear drive information.  
See appropriate controls mounting starting on page 34.

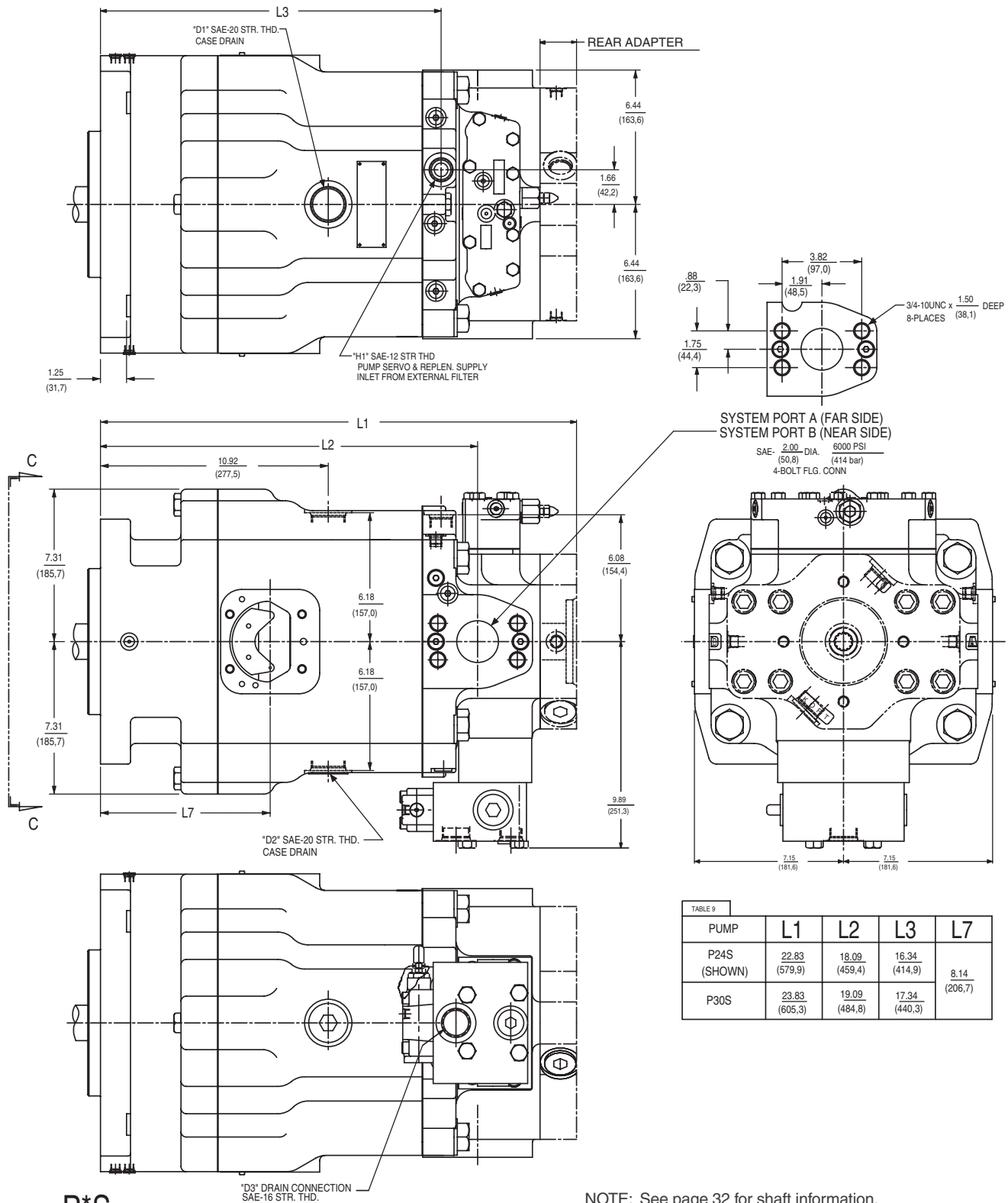

TABLE 9

PUMP	L1	L2	L3	L7
P24S (SHOWN)	22.83 (579.9)	18.09 (459.4)	16.34 (414.9)	8.14 (206.7)
P30S	23.83 (605.3)	19.09 (484.8)	17.34 (440.3)	

NOTE: See page 32 for shaft information.  
 See pages 45-53 for rear drive information.  
 See appropriate controls mounting starting on page 34.

**P24-P30 R, L Dimensions (Less Controls)**

**Hydrostatic Transmission Piston Pumps  
GOLD CUP® Series - Open & Closed Circuits**

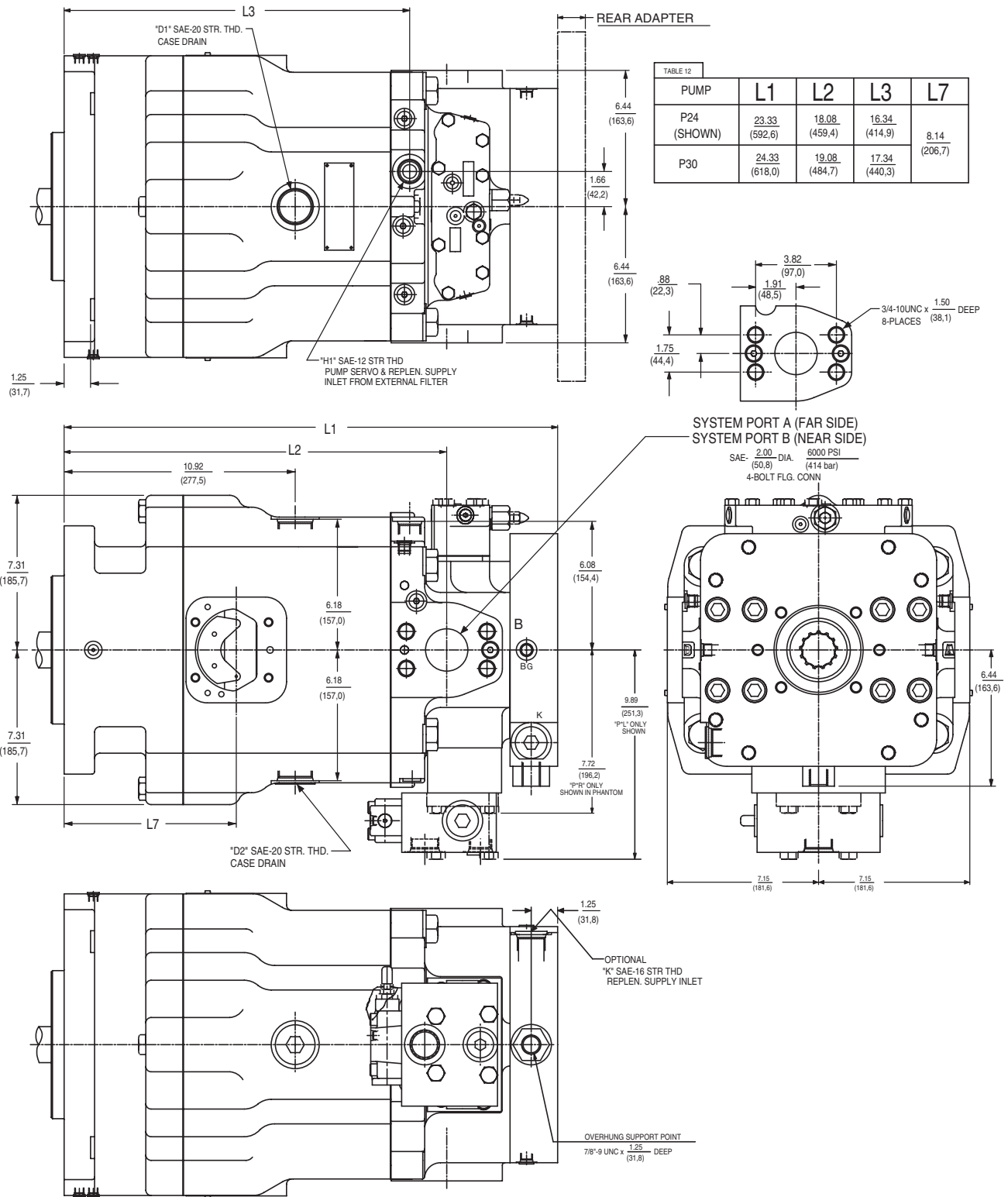

**P\*R & P\*L**

NOTE: See page 32 for shaft information.  
See pages 45-54 for rear drive information.  
See appropriate controls mounting starting on page 34.

**M\*H & M\*V**

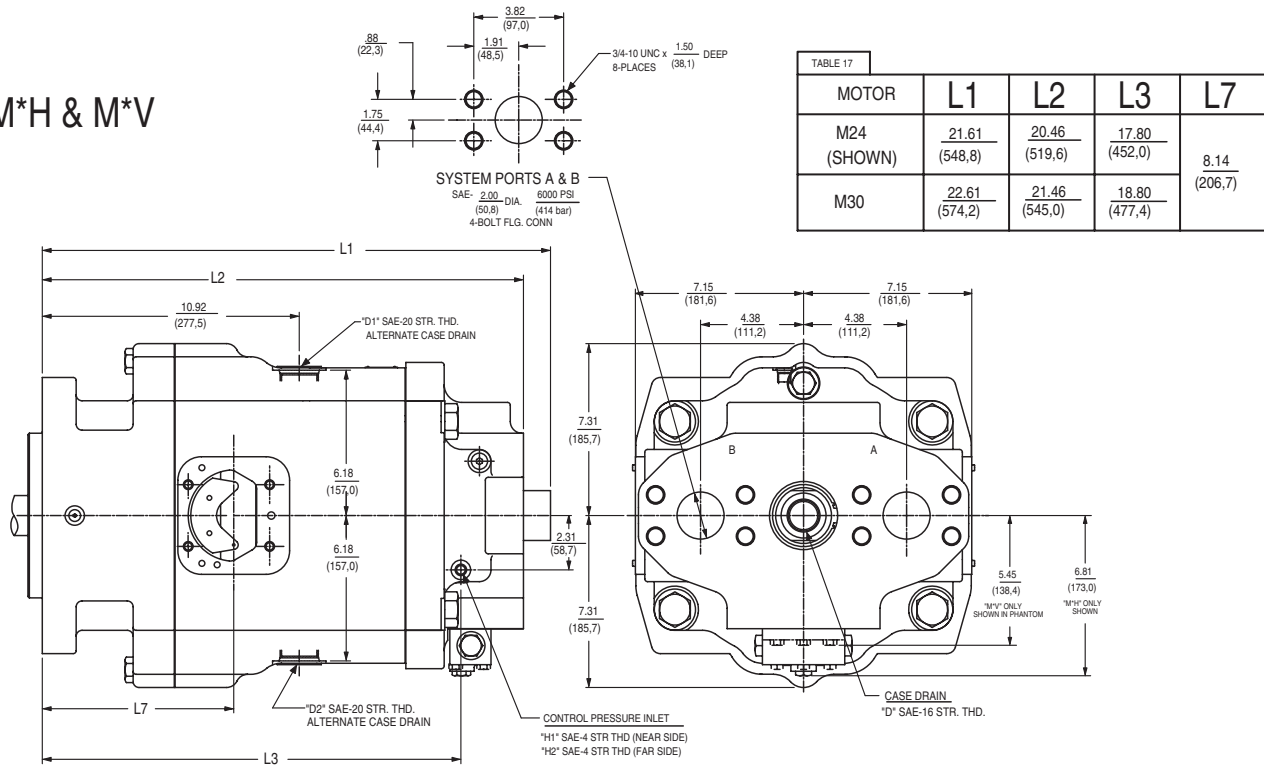

**M\*F & M\*G**

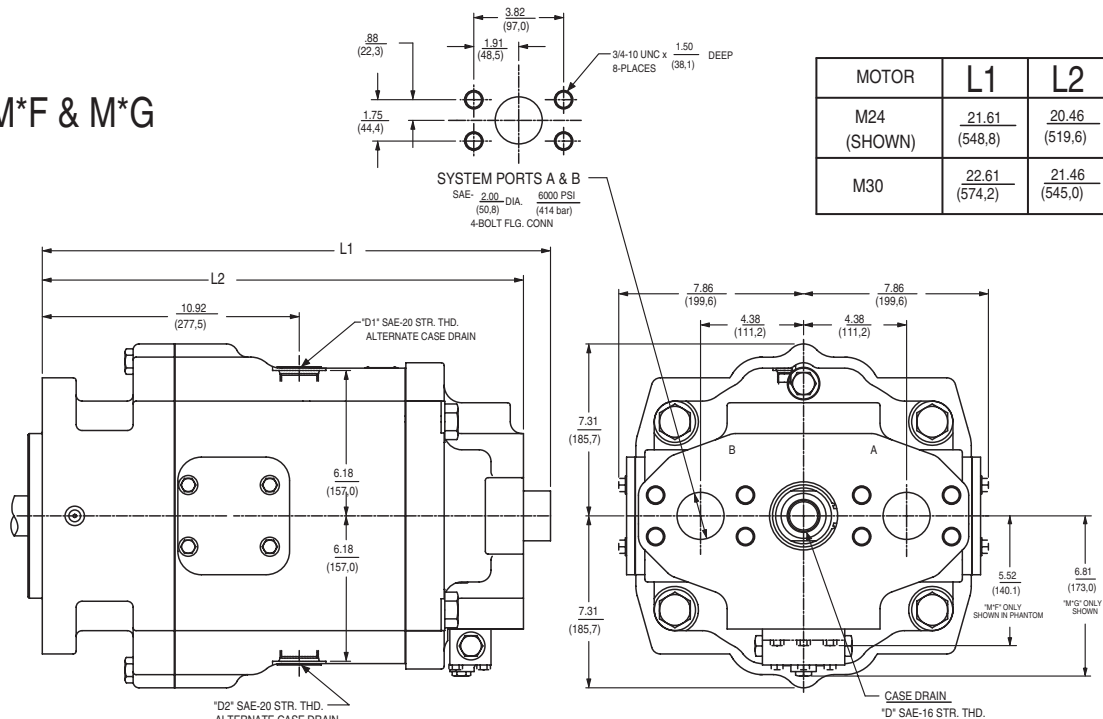

NOTE: See page 32 for shaft information.  
 See appropriate controls mounting starting on page 34.

M\*M & M\*N

PUMP	L1	L2
M24 (SHOWN)	23.33 (592,6)	18.09 (459,4)
M30	24.33 (618,0)	19.09 (484,8)

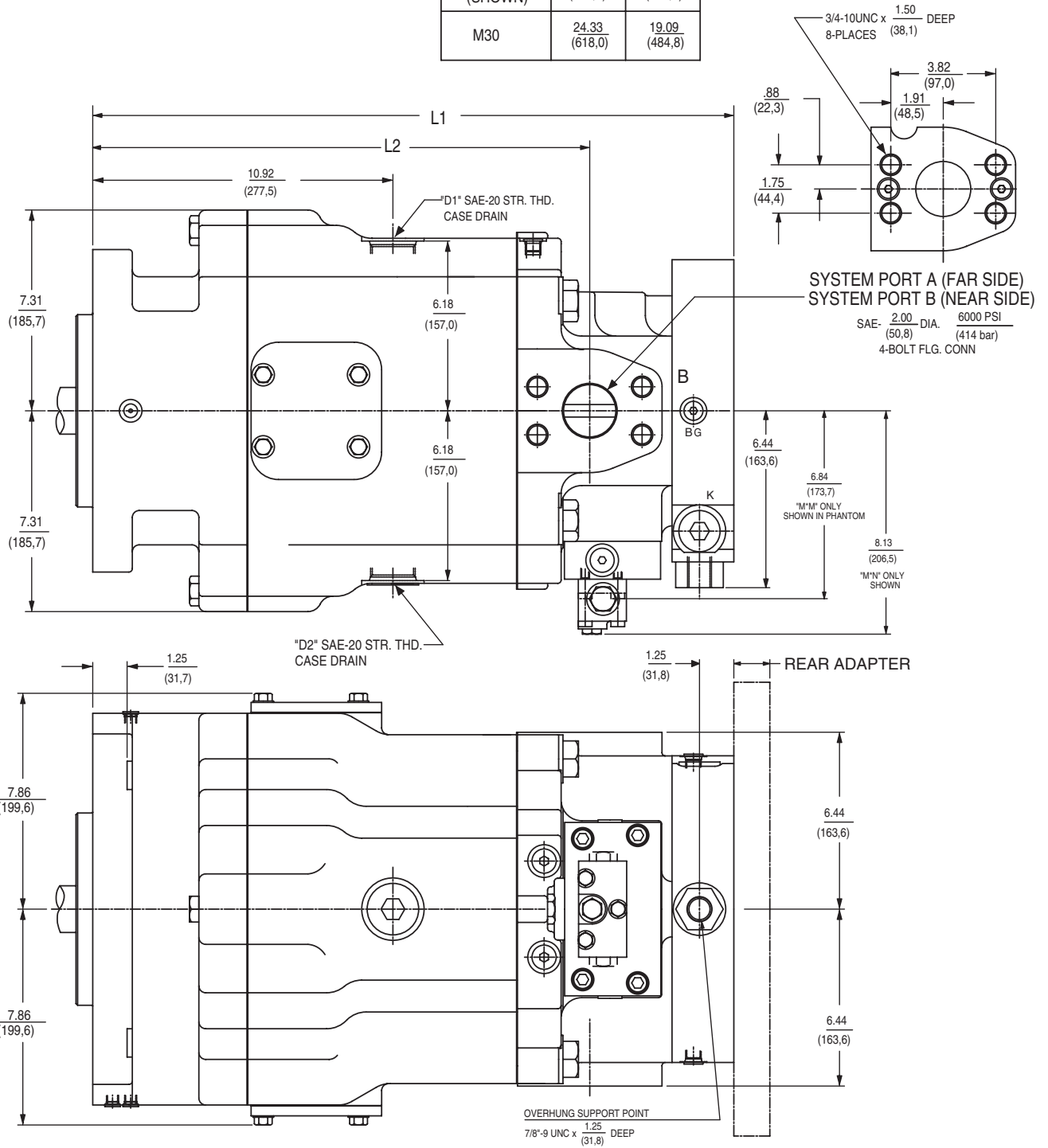

NOTE: See page 32 for shaft information.  
 See pages 45-54 for rear drive information.

M\*R & M\*L

TABLE 18			
PUMP	L1	L2	L7
M24 (SHOWN)	23.33 (592.6)	18.09 (459.4)	8.14 (206.7)
M30	24.33 (618.0)	19.09 (484.8)	

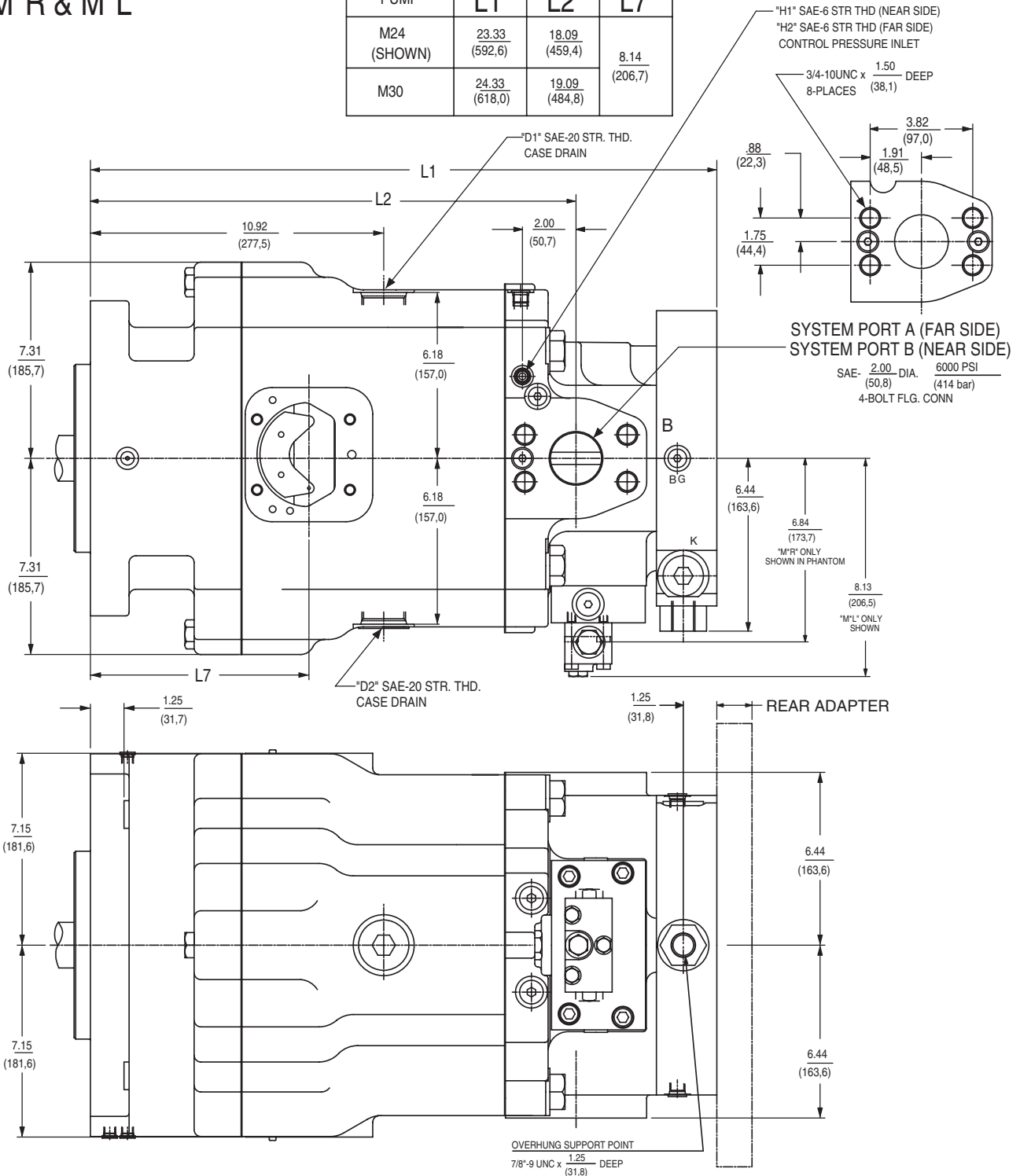

NOTE: See page 32 for shaft information.  
See pages 45-54 for rear drive information.  
See appropriate controls mounting starting on page 34.



**M\*F, M\*G, M\*H, M\*V, P\*S, P\*X, P\*P & P\*F M\*R, M\*L, M\*M, M\*N, P\*L & P\*R**

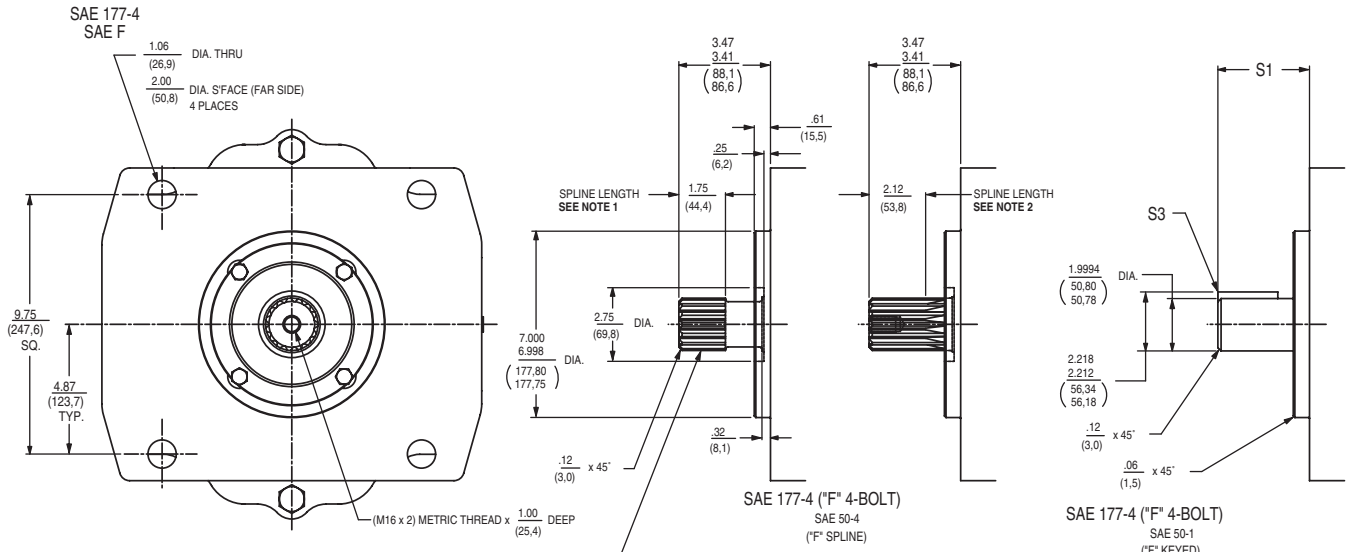

NOTES:  
 1. SPLINE LENGTH AND NECK ONLY FOR:  
 M\*F, M\*G, M\*H, M\*V, P\*S, P\*X, P\*P & P\*F  
 2. SPLINE LENGTH ONLY FOR:  
 M\*R, M\*L, M\*M, M\*N, P\*L & P\*R

SHAFT DESIGNATION PUMP MODEL CODE	SAE INVOLUTE SPLINE DATA J498-B 1969 FLAT ROOT SIDE FIT EXTERNAL CLASS-1 8/16 PITCH 30° PRESSURE ANGLE 15 TEETH 1.9710-1.9660/ (50,063-49,936) MAJOR DIA.
03 or 08	

SHAFT DESIGNATION PUMP MODEL CODE	SHAFT	S1	S3
02 or 07	SAE 50-1 (SAE-F)	3.47/3.41 (88,1/86,6)	.500/.498 (12,70/12,65) SQ. KEY x LG. 2.25 (57,1)
09 or 10	SAE 50-1 LONG (SAE-F)	5.35/5.29 (135,9/134,4)	.500/.498 (12,70/12,65) SQ. KEY x LG. 4.13 (104,9)

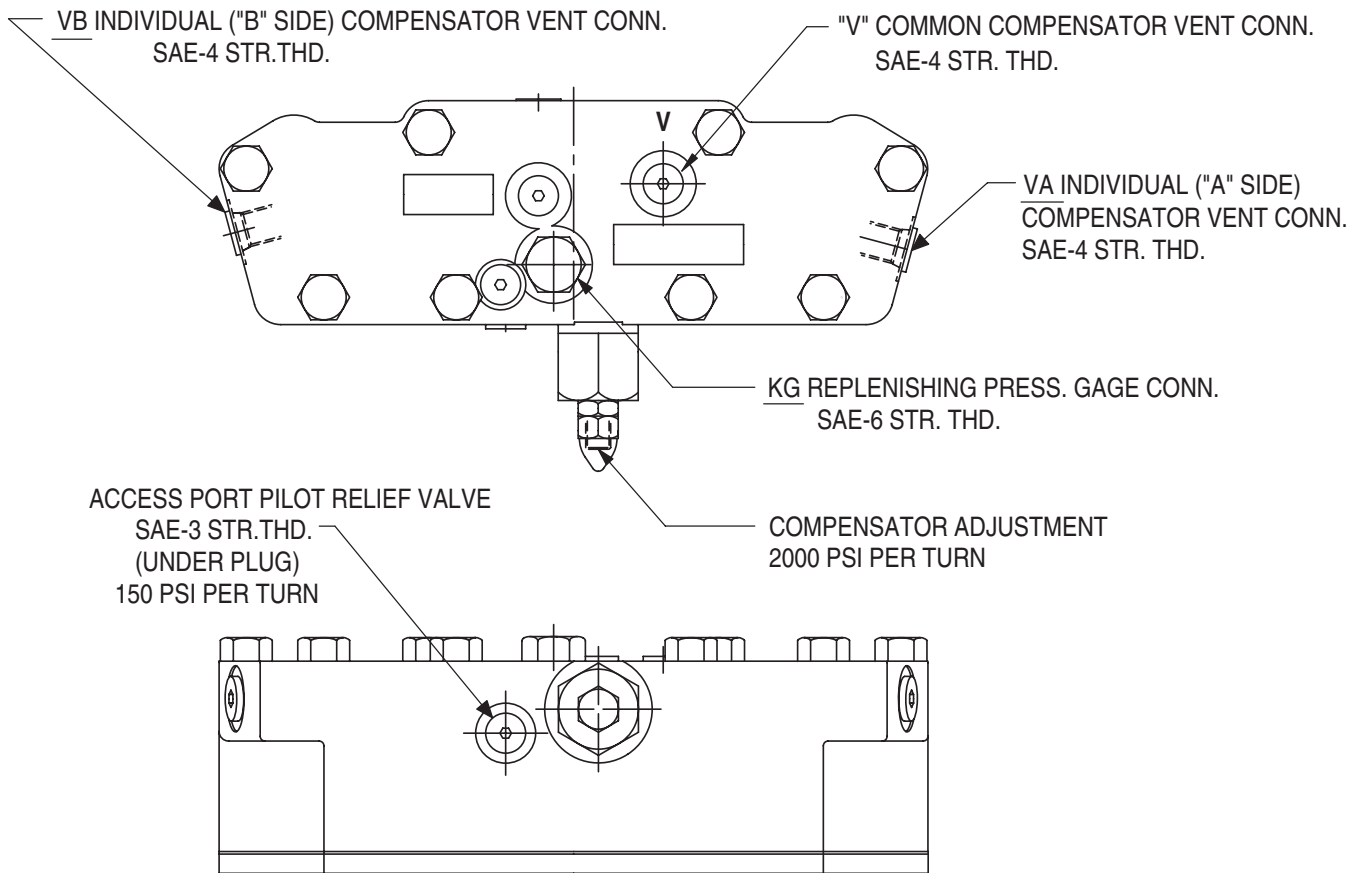

**Pump Primary Controls**

**Hydrostatic Transmission Piston Pumps  
GOLD CUP® Series - Open & Closed Circuits**

-B- CONTROL MTG. POSITION				
CONTROL OPTION	FIG.	PUMP ROT.	ROTARY SERVO INPUT SHAFT ROTATION	PORT "A"
"10"	1	CW	CCW	INLET
	1	CCW	CW	INLET

-A- CONTROL MTG. POSITION				
CONTROL OPTION	FIG.	PUMP ROT.	ROTARY SERVO INPUT SHAFT ROTATION	PORT "A"
"10"	2	CW	CW	INLET
	2	CCW	CCW	INLET

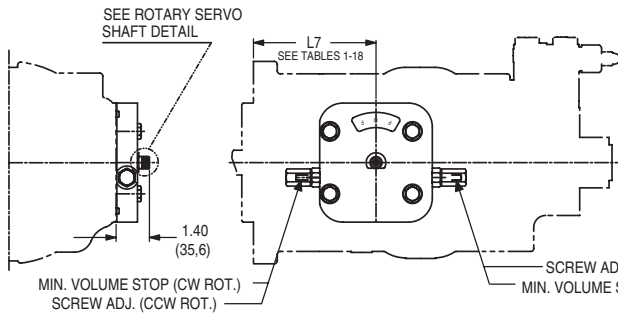

FIGURE -1

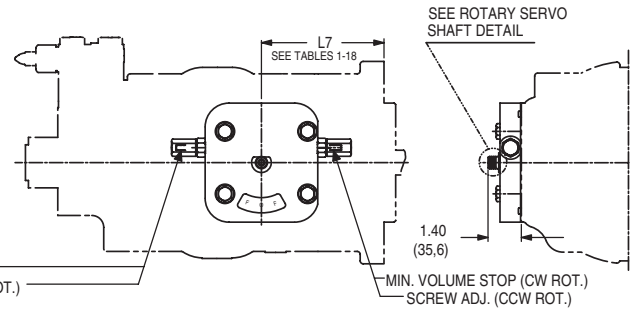

FIGURE -2

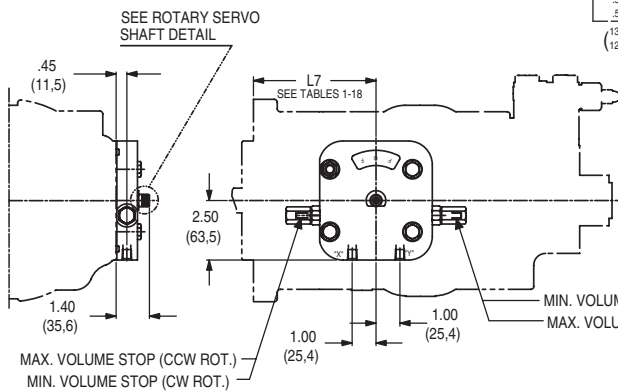
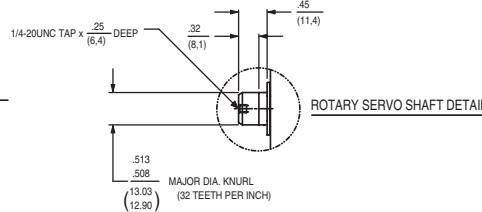

FIGURE -1

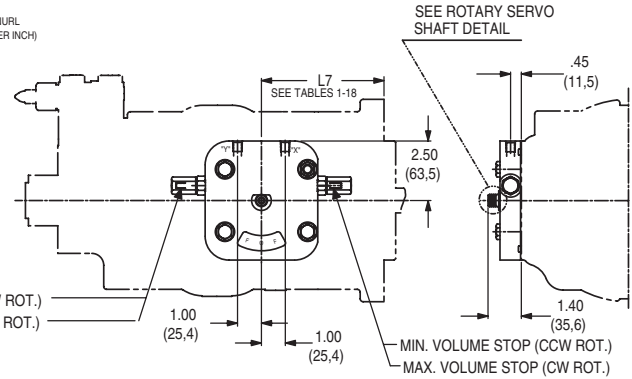

FIGURE -2

-B- CONTROL MTG. POSITION					
CONTROL SPRING OFF-SET TO MIN. VOLUME					
CONTROL OPTION	FIG.	PUMP ROT.	PRESSURE SIGNAL TO:		PORT "A"
			1/8-27 N.P.T.F. PORT "X"	1/8-27 N.P.T.F. PORT "Y"	
"2A"	1	CW	MAX. VOL.	MIN. VOL.	INLET
	1	CCW	MIN. VOL.	MAX. VOL.	INLET

-A- CONTROL MTG. POSITION					
CONTROL SPRING OFF-SET TO MIN. VOLUME					
CONTROL OPTION	FIG.	PUMP ROT.	PRESSURE SIGNAL TO:		PORT "A"
			1/8-27 N.P.T.F. PORT "X"	1/8-27 N.P.T.F. PORT "Y"	
"2A"	2	CW	MIN. VOL.	MAX. VOL.	INLET
	2	CCW	MAX. VOL.	MIN. VOL.	INLET

<b>-B- CONTROL MTG. POSITION</b>						
CONTROL SPRING OFF-SET TO MIN. VOLUME						
CONTROL OPTION	FIG.	PUMP ROT.	PRESSURE SIGNAL TO SAE-4 STR. THD. PORT:	ROTARY SERVO INPUT SHAFT ROTATION	PORT "A"	PORT "B"
"2H"	1	CW	"X"	CCW	INLET	OUTLET
	1	CCW	"Y"	CW	INLET	OUTLET
	1	CW	"Y"	CW	OUTLET	INLET
	1	CCW	"X"	CCW	OUTLET	INLET

<b>-A- CONTROL MTG. POSITION</b>						
CONTROL SPRING OFF-SET TO MIN. VOLUME						
CONTROL OPTION	FIG.	PUMP ROT.	PRESSURE SIGNAL TO SAE-4 STR. THD. PORT:	ROTARY SERVO INPUT SHAFT ROTATION	PORT "A"	PORT "B"
"2H"	2	CW	"Y"	CW	INLET	OUTLET
	2	CCW	"X"	CCW	INLET	OUTLET
	2	CW	"X"	CCW	OUTLET	INLET
	2	CCW	"Y"	CW	OUTLET	INLET
	2	CCW	"Y"	CW	OUTLET	INLET

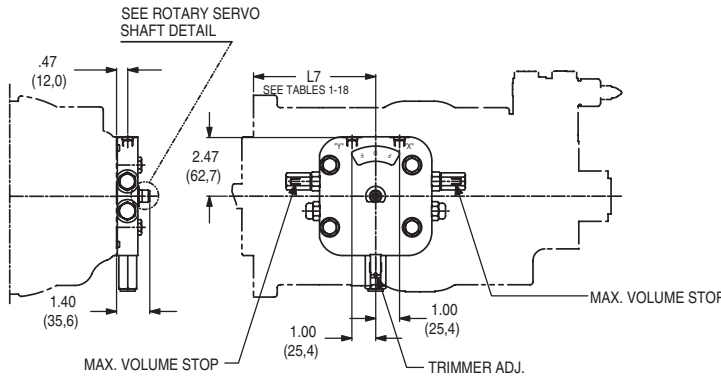

FIGURE -1

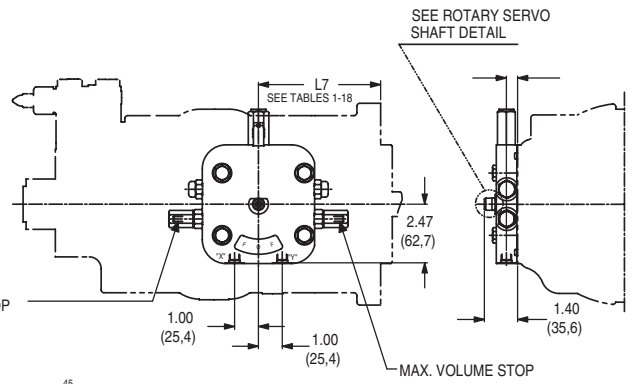

FIGURE -2

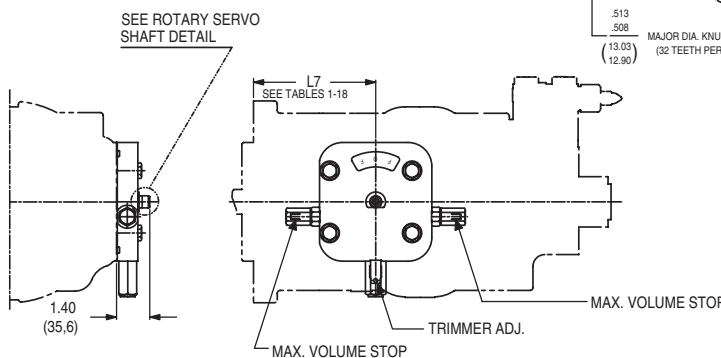
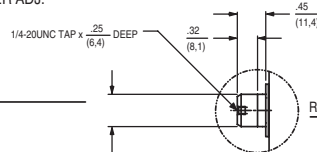

FIGURE -1

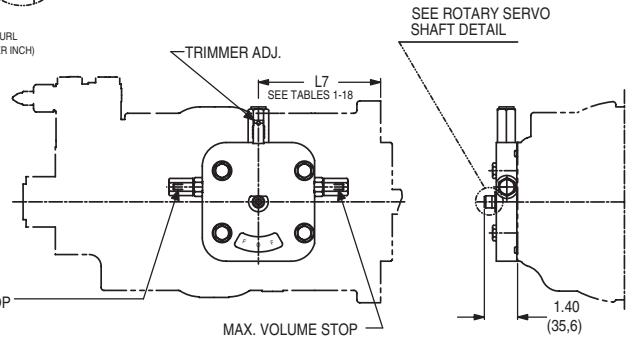

FIGURE -2

<b>-B- CONTROL MTG. POSITION</b>					
CONTROL SPRING OFF-SET TO MIN. VOLUME					
CONTROL OPTION	FIG.	PUMP ROT.	ROTARY SERVO INPUT SHAFT ROTATION	PORT "A"	PORT "B"
"4A"	1	CW	CCW	INLET	OUTLET
	1	CCW	CW	INLET	OUTLET
	1	CW	CW	OUTLET	INLET
	1	CCW	CCW	OUTLET	INLET

<b>-A- CONTROL MTG. POSITION</b>					
CONTROL SPRING OFF-SET TO MIN. VOLUME					
CONTROL OPTION	FIG.	PUMP ROT.	ROTARY SERVO INPUT SHAFT ROTATION	PORT "A"	PORT "B"
"4A"	2	CW	CW	INLET	OUTLET
	2	CCW	CCW	INLET	OUTLET
	2	CW	CCW	OUTLET	INLET
	2	CCW	CW	OUTLET	INLET
	2	CCW	CW	OUTLET	INLET

<b>-B- CONTROL MTG. POSITION</b>					
CONTROL SPRING OFF-SET TO MIN. VOLUME					
CONTROL OPTION	FIG.	PUMP ROT.	ROTARY SERVO INPUT SHAFT ROTATION	PORT "A"	PORT "B"
"5A"	1	CW	CCW	INLET	OUTLET
	1	CCW	CW	INLET	OUTLET
	1	CW	CW	OUTLET	INLET
	1	CCW	CCW	OUTLET	INLET

<b>-A- CONTROL MTG. POSITION</b>					
CONTROL SPRING OFF-SET TO MIN. VOLUME					
CONTROL OPTION	FIG.	PUMP ROT.	ROTARY SERVO INPUT SHAFT ROTATION	PORT "A"	PORT "B"
"5A"	2	CW	CW	INLET	OUTLET
	2	CCW	CCW	INLET	OUTLET
	2	CW	CCW	OUTLET	INLET
	2	CCW	CW	OUTLET	INLET

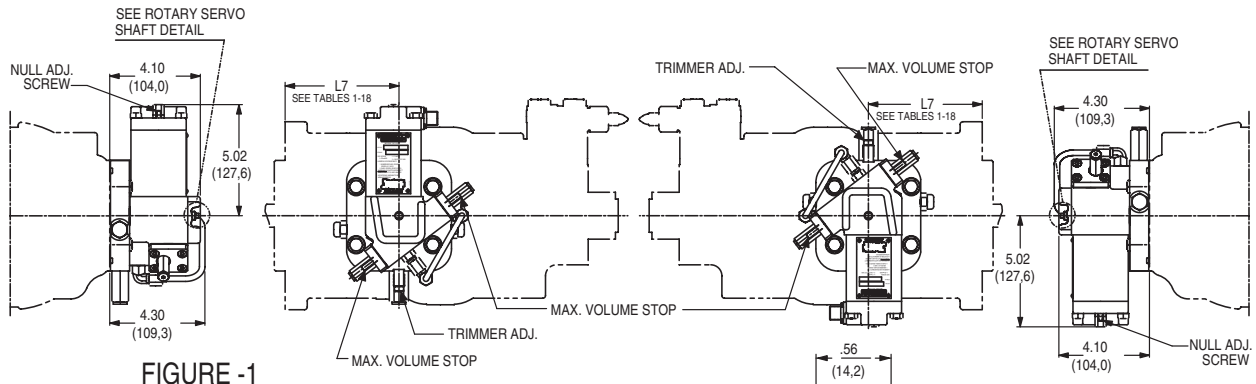

**FIGURE -1**

**FIGURE -2**

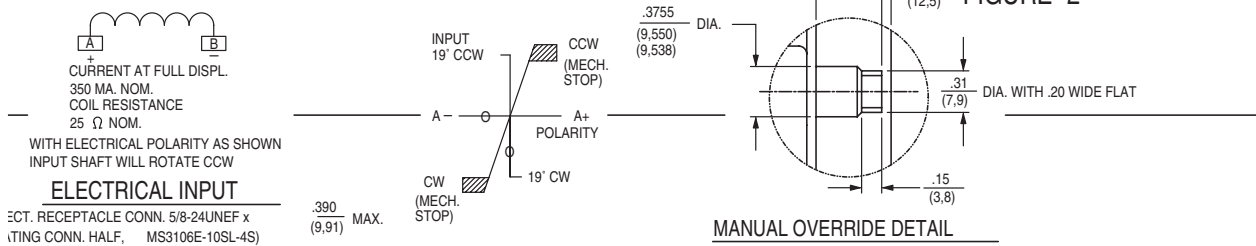

**ELECTRICAL INPUT**

ECT. RECEPTACLE CONN. 5/8-24UNEF x 1/2  
 (MOUNTING CONN. HALF, MS3106E-10SL-4S)

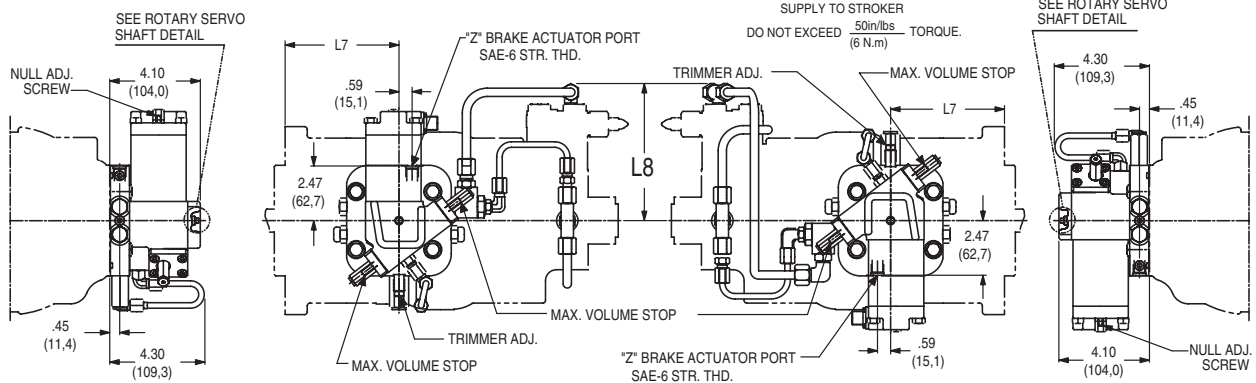

**FIGURE -1**

**FIGURE -2**

<b>-B- CONTROL MTG. POSITION</b>					
CONTROL SPRING OFF-SET TO MIN. VOLUME					
CONTROL OPTION	FIG.	PUMP ROT.	ROTARY SERVO INPUT SHAFT ROTATION	PORT "A"	PORT "B"
"5C"	1	CW	CCW	INLET	OUTLET
	1	CCW	CW	INLET	OUTLET
	1	CW	CW	OUTLET	INLET
	1	CCW	CCW	OUTLET	INLET

SERIES SIZE	L7	L8
6, 7 & 8 (SAE 127-2)	5.15 (130,9)	6.20 (157,4)
6, 7 & 8 (SAE 152-4)	6.49 (164,8)	
11 & 14	6.38 (162,0)	6.77 (171,9)
24 & 30	8.14 (206,7)	8.64 (219,4)

<b>-A- CONTROL MTG. POSITION</b>					
CONTROL SPRING OFF-SET TO MIN. VOLUME					
CONTROL OPTION	FIG.	PUMP ROT.	ROTARY SERVO INPUT SHAFT ROTATION	PORT "A"	PORT "B"
"5C"	2	CW	CW	INLET	OUTLET
	2	CCW	CCW	INLET	OUTLET
	2	CW	CCW	OUTLET	INLET
	2	CCW	CW	OUTLET	INLET

-B- CONTROL MTG. POSITION					
CONTROL OPTION	FIG.	PUMP ROT.	INDICATOR ROTATION	PORT "A"	PORT "B"
"7D**"	1	CW	CCW	INLET	OUTLET
	1	CCW	CW	INLET	OUTLET
	1	CW	CW	OUTLET	INLET
	1	CCW	CCW	OUTLET	INLET

SERIES SIZE	L7	L8	L9
6, 7 & 8 (SAE 127-2)	5.15 (130.9)	9.43 (239.6)	5.63 (143.1)
6, 7 & 8 (SAE 152-4)	6.49 (164.8)		
11 & 14	6.38 (162.0)	10.00 (254.1)	6.20 (157.5)
24 & 30	8.14 (206.7)	11.87 (301.5)	8.07 (205.0)

-A- CONTROL MTG. POSITION					
CONTROL OPTION	FIG.	PUMP ROT.	INDICATOR ROTATION	PORT "A"	PORT "B"
"7D**"	2	CW	CW	INLET	OUTLET
	2	CCW	CCW	INLET	OUTLET
	2	CW	CCW	OUTLET	INLET
	2	CCW	CW	OUTLET	INLET

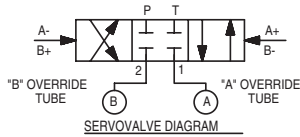

PUMP ROT.	CAM	SERVOVALVE		PORT "A"	PORT "B"
		COIL POLARITY	PORTING		
CW	ABOVE	A+ or B-	P---2 ▶	OUTLET	INLET
CW	BELOW	A- or B+	P---1 ▶	INLET	OUTLET
CCW	BELOW	A+ or B-	P---2 ▶	OUTLET	INLET
CCW	ABOVE	A- or B+	P---1 ▶	INLET	OUTLET

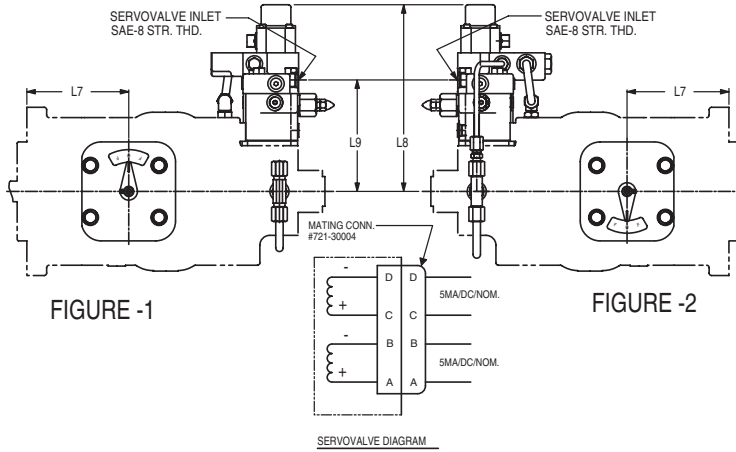

-B- CONTROL MTG. POSITION						
CONTROL OPTION	FIG.	PUMP ROT.	VALVE COMMAND DTO E	VOL. INDICATOR SHAFT ROT. (SHOWN)	PORT "A"	PORT "B"
"7J**"	1	CW	0...-10V	CCW	INLET	OUTLET
	1	CCW	0...-10V	CW	INLET	OUTLET
	1	CW	0...+10V	CW	OUTLET	INLET
	1	CCW	0...+10V	CCW	OUTLET	INLET

SERIES SIZE	L7	L8	L9	L10
6, 7 & 8 (SAE 127-2)	5.15 (130.9)	12.70 (322.6)	5.63 (143.1)	7.66 (194.6)
6, 7 & 8 (SAE 152-4)	6.49 (164.8)			
11 & 14	6.38 (162.0)	14.37 (365.0)	6.20 (157.5)	
24 & 30	8.14 (206.7)	14.58 (370.3)	8.07 (205.0)	

-A- CONTROL MTG. POSITION						
CONTROL OPTION	FIG.	PUMP ROT.	VALVE COMMAND DTO E	VOL. INDICATOR SHAFT ROT. (SHOWN)	PORT "A"	PORT "B"
"7J**"	2	CW	0...-10V	CW	INLET	OUTLET
	2	CCW	0...-10V	CCW	INLET	OUTLET
	2	CW	0...+10V	CCW	OUTLET	INLET
	2	CCW	0...+10V	CW	OUTLET	INLET

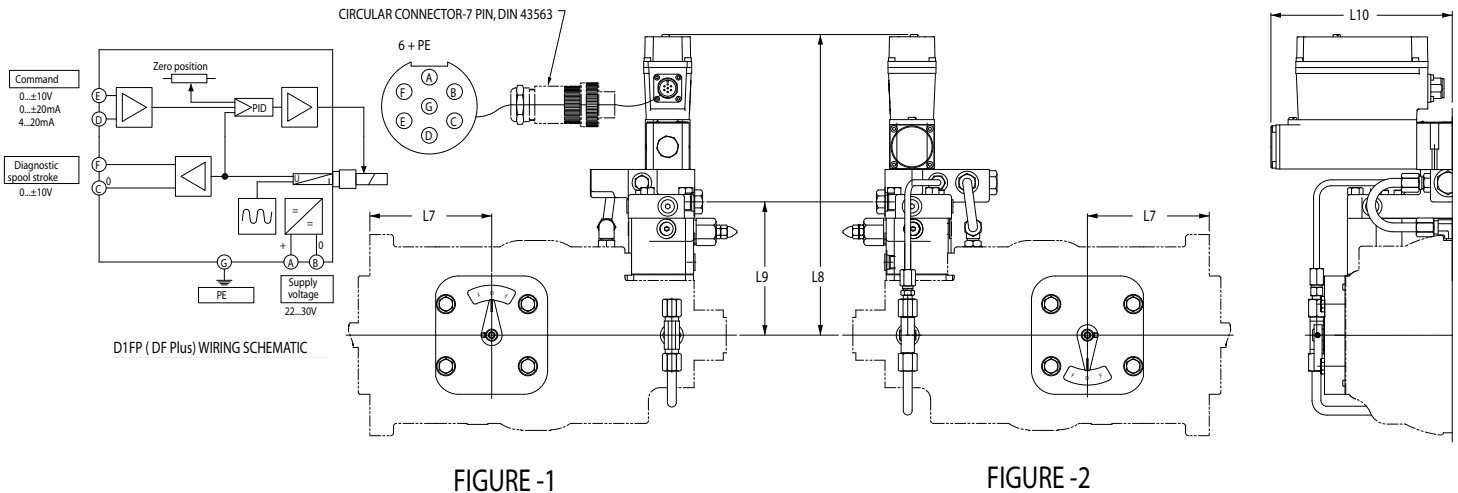

-B- CONTROL MTG. POSITION					
CONTROL OPTION	FIG.	PUMP ROT.	ROTARY SERVO INPUT SHAFT ROTATION	PORT "A"	PORT "B"
"7F**"	1	CW	CCW	INLET	OUTLET
	1	CCW	CW	INLET	OUTLET
	1	CW	CW	OUTLET	INLET
	1	CCW	CCW	OUTLET	INLET

SERIES SIZE	L7	L8	L9
6, 7 & 8 (SAE 127-2)	5.15 (130.9)	9.43 (239.6)	5.63 (143.1)
6, 7 & 8 (SAE 152-4)	6.49 (164.8)		
11 & 14	6.38 (162.0)	10.00 (254.1)	6.20 (157.5)
24 & 30	8.14 (206.7)	11.87 (301.5)	8.07 (205.0)

-A- CONTROL MTG. POSITION					
CONTROL OPTION	FIG.	PUMP ROT.	ROTARY SERVO INPUT SHAFT ROTATION	PORT "A"	PORT "B"
"7F**"	2	CW	CW	INLET	OUTLET
	2	CCW	CCW	INLET	OUTLET
	2	CW	CCW	OUTLET	INLET
	2	CCW	CW	OUTLET	INLET

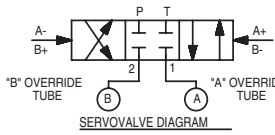

PUMP ROT.	CAM	SERVOVALVE		PORT "A"	PORT "B"
		COIL POLARITY	PORTING		
CW	ABOVE	A+ or B-	P---2 ▶	OUTLET	INLET
CW	BELOW	A- or B+	P---1 ▶	INLET	OUTLET
CCW	BELOW	A+ or B-	P---2 ▶	OUTLET	INLET
CCW	ABOVE	A- or B+	P---1 ▶	INLET	OUTLET

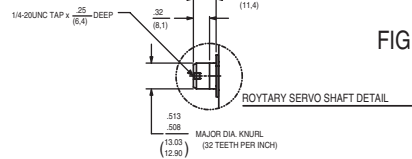
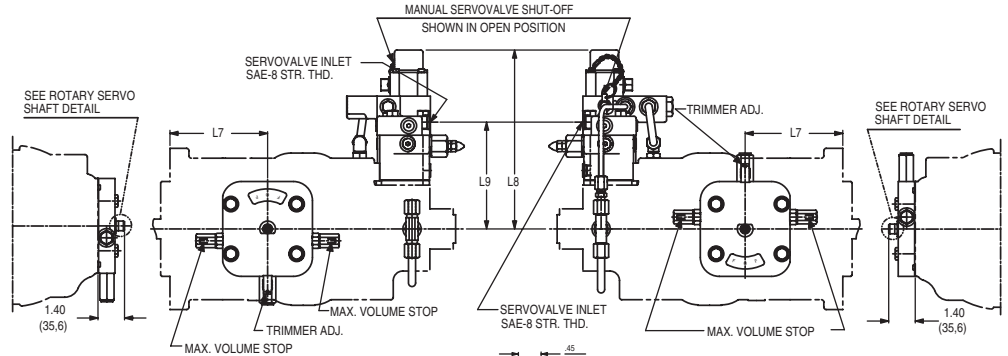

-B- CONTROL MTG. POSITION						
CONTROL OPTION	FIG.	PUMP ROT.	VALVE COMMAND D TO E	CONTROL INPUT SHAFT ROT. (SHOWN)	PORT "A"	PORT "B"
"7K**"	1	CW	0...-10V	CCW	INLET	OUTLET
	1	CCW	0...-10V	CW	INLET	OUTLET
	1	CW	0...+10V	CW	OUTLET	INLET
	1	CCW	0...+10V	CCW	OUTLET	INLET

SERIES SIZE	L7	L8	L9	L10
6, 7 & 8 (SAE 127-2)	5.15 (130.9)	12.70 (322.6)	5.63 (143.1)	7.66 (194.6)
6, 7 & 8 (SAE 152-4)	6.49 (164.8)			
11 & 14	6.38 (162.0)	14.37 (365.0)	6.20 (157.5)	
24 & 30	8.14 (206.7)	14.58 (370.3)	8.07 (205.0)	

-A- CONTROL MTG. POSITION						
CONTROL OPTION	FIG.	PUMP ROT.	VALVE COMMAND D TO E	CONTROL INPUT SHAFT ROT. (SHOWN)	PORT "A"	PORT "B"
"7K**"	2	CW	0...-10V	CW	INLET	OUTLET
	2	CCW	0...-10V	CCW	INLET	OUTLET
	2	CW	0...+10V	CCW	OUTLET	INLET
	2	CCW	0...+10V	CW	OUTLET	INLET

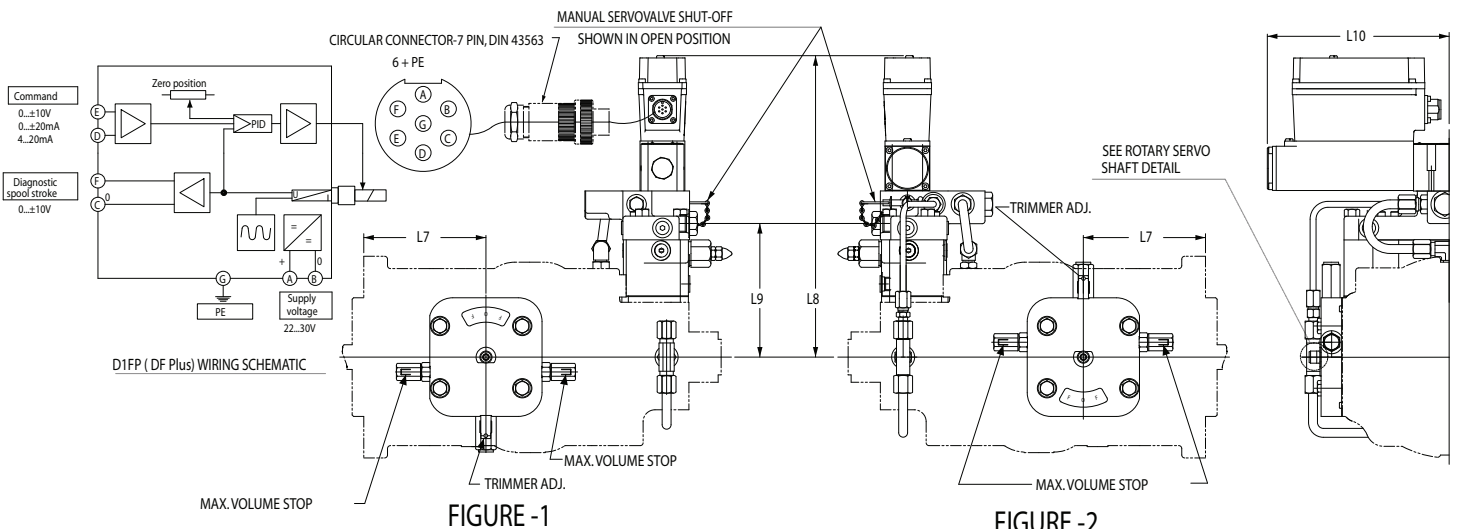

<b>-B- CONTROL MTG. POSITION</b>						
CONTROL SPRING OFF-SET TO MIN, VOLUME						
CONTROL OPTION	FIG.	PUMP ROT.	PRESSURE SIGNAL TO SAE-4 STR. THD. PORT:	ROTARY SERVO INPUT SHAFT ROTATION	PORT "A"	PORT "B"
"8A"	1	CW	"P1"	CCW	INLET	OUTLET
	1	CCW	"P2"	CW	INLET	OUTLET
	1	CW	"P2"	CW	OUTLET	INLET
	1	CCW	"P1"	CCW	OUTLET	INLET

<b>-A- CONTROL MTG. POSITION</b>						
CONTROL SPRING OFF-SET TO MIN, VOLUME						
CONTROL OPTION	FIG.	PUMP ROT.	PRESSURE SIGNAL TO SAE-4 STR. THD. PORT:	ROTARY SERVO INPUT SHAFT ROTATION	PORT "A"	PORT "B"
"8A"	2	CW	"P2"	CW	INLET	OUTLET
	2	CCW	"P1"	CCW	INLET	OUTLET
	2	CW	"P1"	CCW	OUTLET	INLET
	2	CCW	"P2"	CW	OUTLET	INLET
	2	CW	"P2"	CW	OUTLET	INLET
	2	CCW	"P1"	CCW	OUTLET	INLET

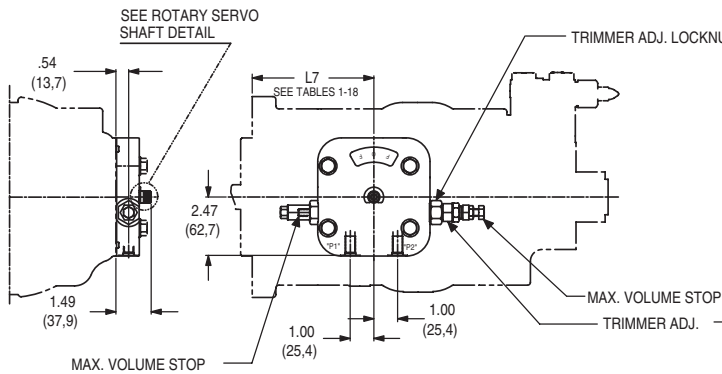

**FIGURE -1**

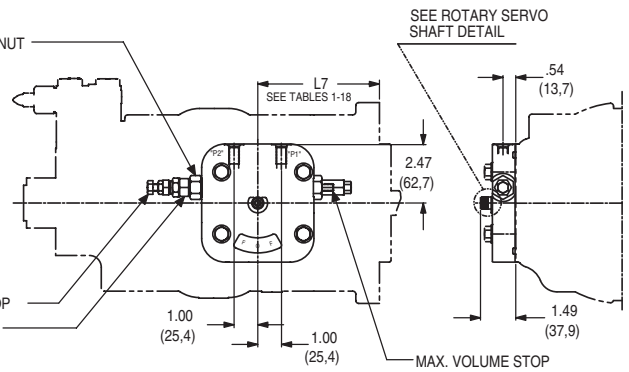

**FIGURE -2**

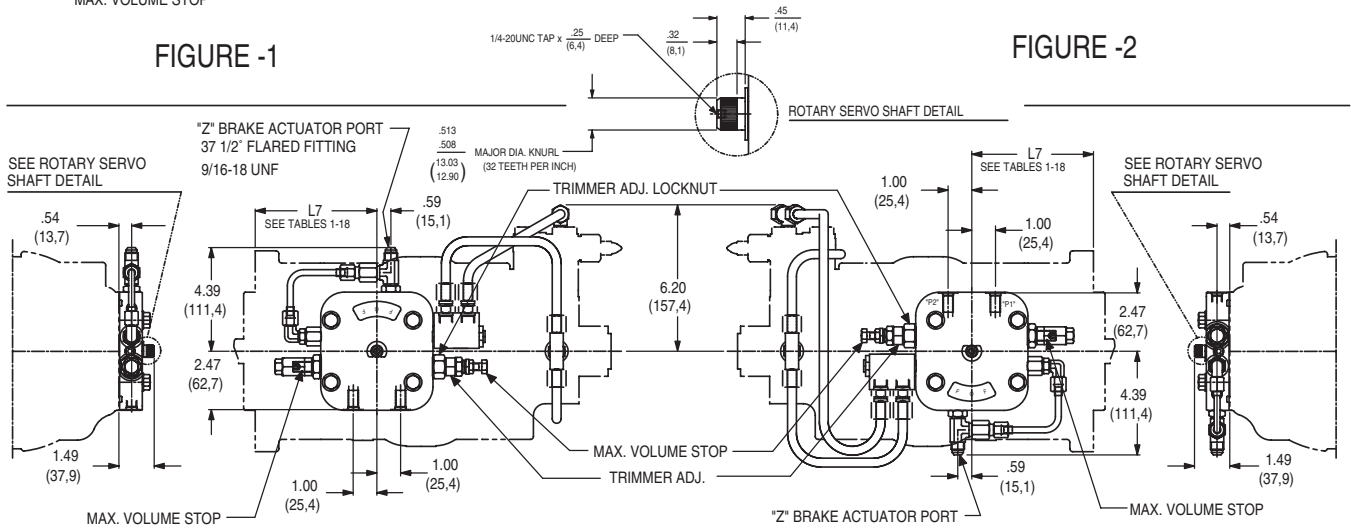

**FIGURE -1**

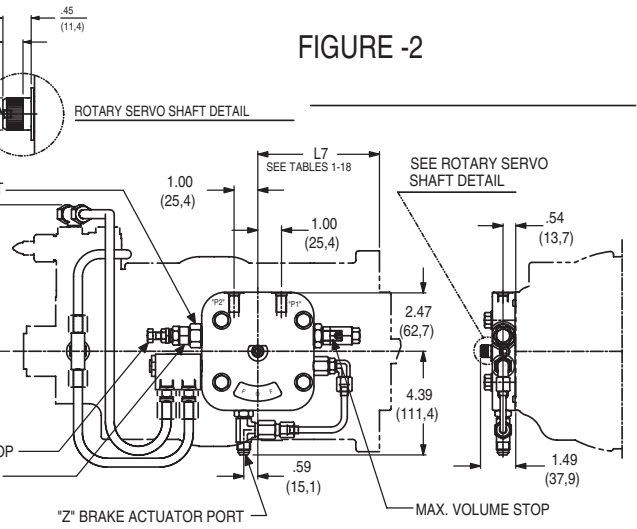

**FIGURE -2**

<b>-B- CONTROL MTG. POSITION</b>						
CONTROL SPRING OFF-SET TO MIN, VOLUME						
CONTROL OPTION	FIG.	PUMP ROT.	PRESSURE SIGNAL TO SAE-4 STR. THD. PORT:	ROTARY SERVO INPUT SHAFT ROTATION	PORT "A"	PORT "B"
"8C"	1	CW	"P1"	CCW	INLET	OUTLET
	1	CCW	"P2"	CW	INLET	OUTLET
	1	CW	"P2"	CW	OUTLET	INLET
	1	CCW	"P1"	CCW	OUTLET	INLET

<b>-A- CONTROL MTG. POSITION</b>						
CONTROL SPRING OFF-SET TO MIN, VOLUME						
CONTROL OPTION	FIG.	PUMP ROT.	PRESSURE SIGNAL TO SAE-4 STR. THD. PORT:	ROTARY SERVO INPUT SHAFT ROTATION	PORT "A"	PORT "B"
"8C"	2	CW	"P2"	CW	INLET	OUTLET
	2	CCW	"P1"	CCW	INLET	OUTLET
	2	CW	"P1"	CCW	OUTLET	INLET
	2	CCW	"P2"	CW	OUTLET	INLET
	2	CW	"P2"	CW	OUTLET	INLET
	2	CCW	"P1"	CCW	OUTLET	INLET



**Pump Primary Controls**

**Hydrostatic Transmission Piston Pumps  
GOLD CUP® Series - Open & Closed Circuits**

-B- CONTROL MTG. POSITION						
CONTROL OPTION	FIG.	PUMP ROT.	ENERGIZE SOLENOID	MANUAL OVERRIDE SHAFT ROTATION	PORT "A"	PORT "B"
"9A"	1	CW	"A"	CCW	INLET	OUTLET
	1	CCW	"B"	CW	INLET	OUTLET
	1	CW	"B"	CW	OUTLET	INLET
	1	CCW	"A"	CCW	OUTLET	INLET

-A- CONTROL MTG. POSITION						
CONTROL OPTION	FIG.	PUMP ROT.	ENERGIZE SOLENOID	MANUAL OVERRIDE SHAFT ROTATION	PORT "A"	PORT "B"
"9A"	2	CW	"B"	CW	INLET	OUTLET
	2	CCW	"A"	CCW	INLET	OUTLET
	2	CW	"A"	CCW	OUTLET	INLET
	2	CCW	"B"	CW	OUTLET	INLET

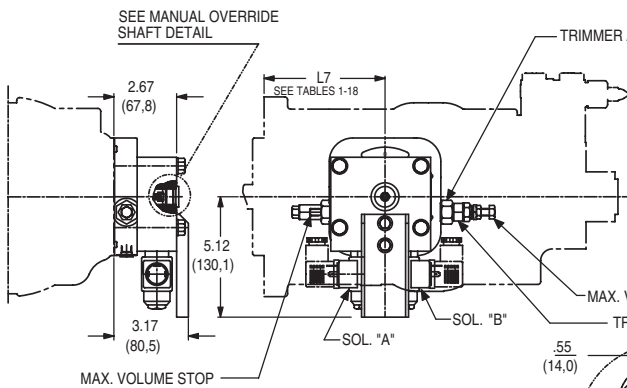

FIGURE -1

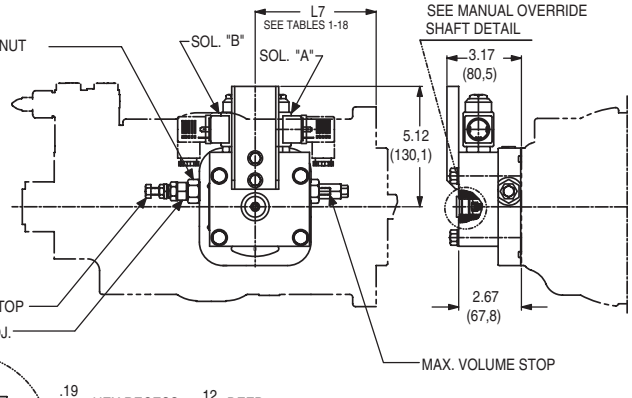

FIGURE -2

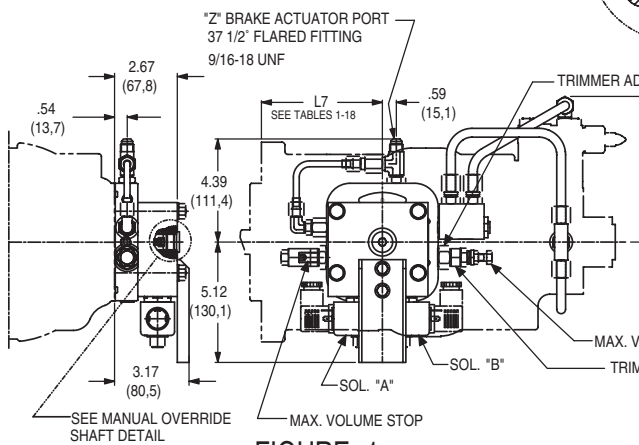

FIGURE -1

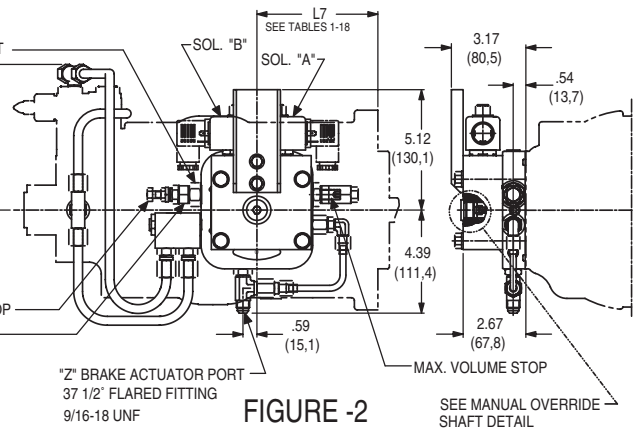

FIGURE -2

-B- CONTROL MTG. POSITION						
CONTROL OPTION	FIG.	PUMP ROT.	ENERGIZE SOLENOID	MANUAL OVERRIDE SHAFT ROTATION	PORT "A"	PORT "B"
"9C"	1	CW	"A"	CCW	INLET	OUTLET
	1	CCW	"B"	CW	INLET	OUTLET
	1	CW	"B"	CW	OUTLET	INLET
	1	CCW	"A"	CCW	OUTLET	INLET

-A- CONTROL MTG. POSITION						
CONTROL OPTION	FIG.	PUMP ROT.	ENERGIZE SOLENOID	MANUAL OVERRIDE SHAFT ROTATION	PORT "A"	PORT "B"
"9C"	2	CW	"B"	CW	INLET	OUTLET
	2	CCW	"A"	CCW	INLET	OUTLET
	2	CW	"A"	CCW	OUTLET	INLET
	2	CCW	"B"	CW	OUTLET	INLET

-B- CONTROL MTG. POSITION					
CONTROL SPRING OFF-SET TO FULL VOLUME					
CONTROL OPTION	FIG.	MOTOR ROT.	PRESSURE SIGNAL TO:		PORT "A"
			1/8-27 N.P.T.F. PORT "X"	1/8-27 N.P.T.F. PORT "Y"	
"2A**"	1	CW	REDUCED SPEED	FULL SPEED	INLET
	1	CCW			OUTLET

-A- CONTROL MTG. POSITION					
CONTROL SPRING OFF-SET TO FULL VOLUME					
CONTROL OPTION	FIG.	MOTOR ROT.	PRESSURE SIGNAL TO:		PORT "A"
			1/8-27 N.P.T.F. PORT "X"	1/8-27 N.P.T.F. PORT "Y"	
"2A**"	2	CW	FULL SPEED	REDUCED SPEED	INLET
	2	CCW			OUTLET

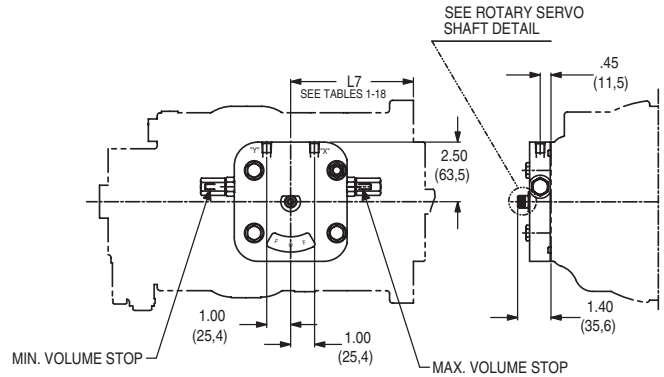
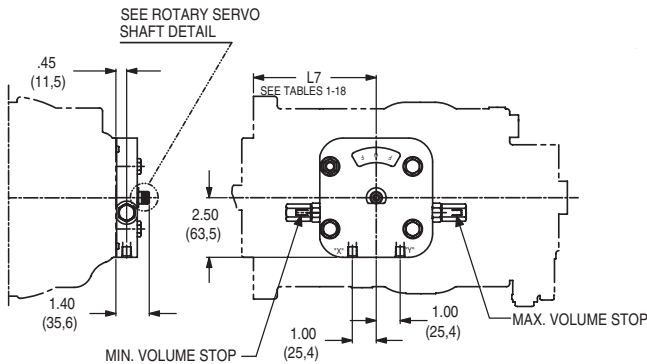

FIGURE -1

FIGURE -2

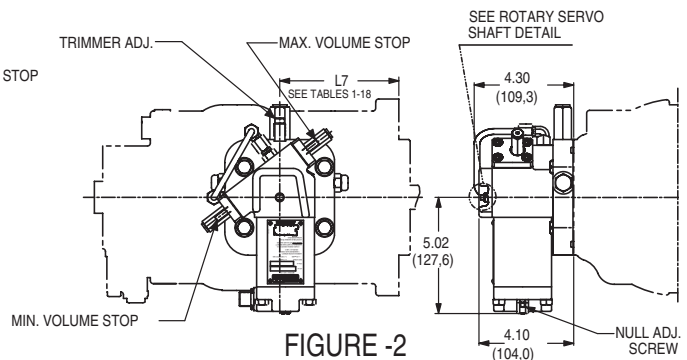
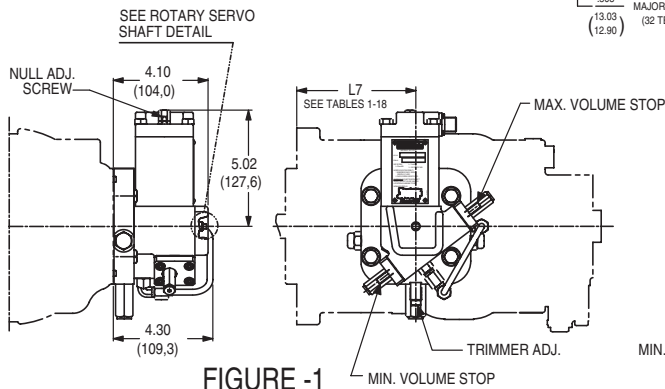
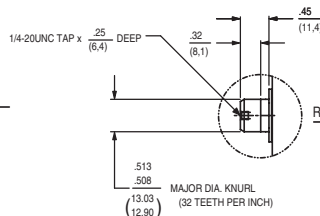

FIGURE -1

FIGURE -2

-B- CONTROL MTG. POSITION						
CONTROL SPRING OFF-SET TO FULL VOLUME						
CONTROL OPTION	FIG.	MOTOR ROT.	ROTARY SERVO INPUT SHAFT	ROTARY SERVO INPUT SHAFT	PORT "A"	PORT "B"
			CCW ROTATION	CW ROTATION		
"5A**"	1	CW			INLET	OUTLET
	1	CCW	REDUCED SPEED	FULL SPEED	OUTLET	INLET

-A- CONTROL MTG. POSITION						
CONTROL SPRING OFF-SET TO FULL VOLUME						
CONTROL OPTION	FIG.	MOTOR ROT.	ROTARY SERVO INPUT SHAFT	ROTARY SERVO INPUT SHAFT	PORT "A"	PORT "B"
			CCW ROTATION	CW ROTATION		
"5A**"	2	CW			INLET	OUTLET
	2	CCW	FULL SPEED	REDUCED SPEED	OUTLET	INLET

**Motor Primary Controls**

**Hydrostatic Transmission Piston Pumps  
GOLD CUP® Series - Open & Closed Circuits**

<b>-B- CONTROL MTG. POSITION</b>						
CONTROL SPRING OFF-SET TO FULL VOLUME						
CONTROL OPTION	FIG.	MOTOR ROT.	PRESSURE SIGNAL TO SAE-4 STR. THD. PORT P2	ROTARY SERVO INPUT SHAFT ROTATION	PORT "A"	PORT "B"
"8A"	1	CW	FULL SPEED	CW	INLET	OUTLET
	1	CCW		CW	OUTLET	INLET

<b>-A- CONTROL MTG. POSITION</b>						
CONTROL SPRING OFF-SET TO FULL VOLUME						
CONTROL OPTION	FIG.	MOTOR ROT.	PRESSURE SIGNAL TO SAE-4 STR. THD. PORT P1	ROTARY SERVO INPUT SHAFT ROTATION	PORT "A"	PORT "B"
"8A"	2	CW	FULL SPEED	CCW	INLET	OUTLET
	2	CCW		CCW	OUTLET	INLET

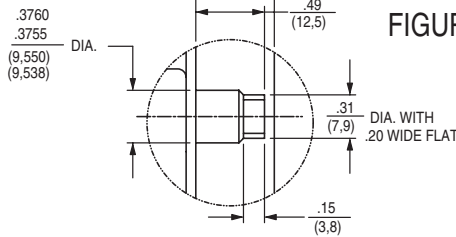
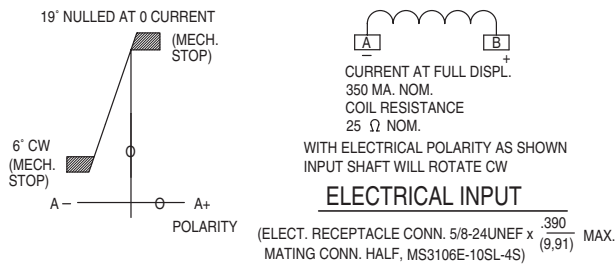
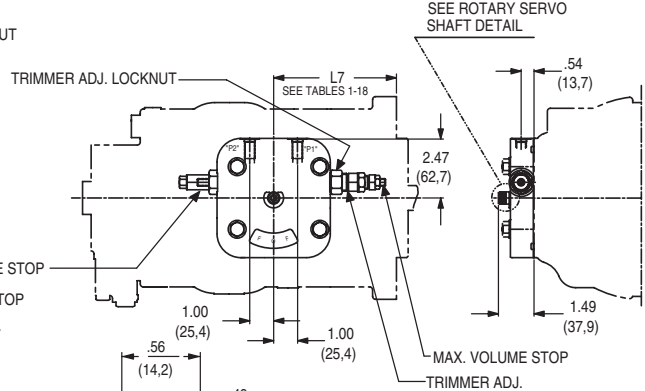
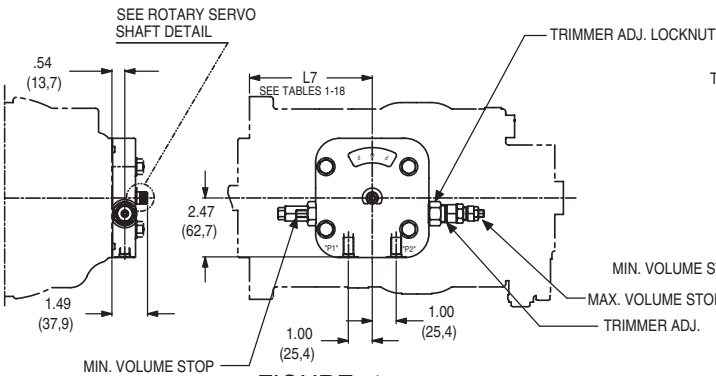

**MANUAL OVERRIDE DETAIL**  
SERVO MUST BE DISCONNECTED

<b>-B- CONTROL MTG. POSITION</b>						
CONTROL SPRING OFF-SET TO FULL VOLUME						
CONTROL OPTION	FIG.	MOTOR ROT.	ENERGIZE SOLENOID	MANUAL OVERRIDE SHAFT ROTATION	PORT "A"	PORT "B"
"9A"	1	CW	FULL SPEED	CW	INLET	OUTLET
	1	CCW		CW	OUTLET	INLET

<b>-A- CONTROL MTG. POSITION</b>						
CONTROL SPRING OFF-SET TO FULL VOLUME						
CONTROL OPTION	FIG.	MOTOR ROT.	ENERGIZE SOLENOID	MANUAL OVERRIDE SHAFT ROTATION	PORT "A"	PORT "B"
"9A"	2	CW	FULL SPEED	CCW	INLET	OUTLET
	2	CCW		CCW	OUTLET	INLET

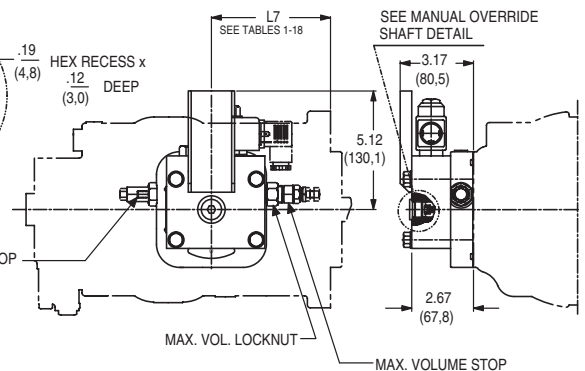
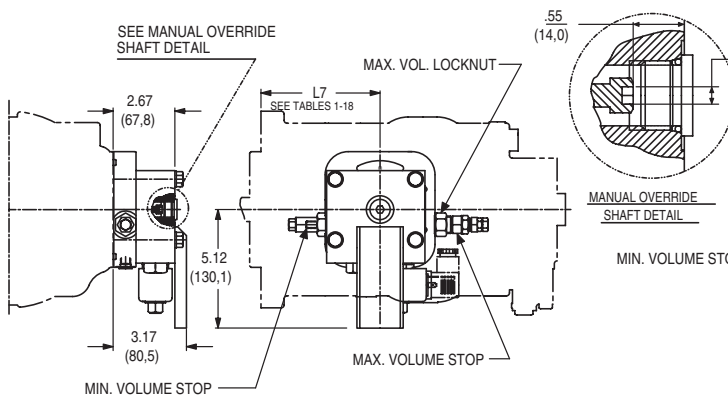

FIGURE -1

FIGURE -2

-A- CONTROL MTG. POSITION						
CONTROL OPTION	FIG.	PUMP ROT.	INPUT SHAFT ROTATION	PORT "A"	PORT "B"	TORQUE LIMITER ADJ.
***4"	3	CW	CW	INLET	OUTLET	E
	1	CCW	CCW	INLET	OUTLET	F
	1	CCW	CW	OUTLET	INLET	E
	3	CW	CCW	OUTLET	INLET	F

SERIES SIZE	L7	L10	L11
6, 7 & 8 (SAE 127-2)	5.15 (130.9)	6.20 (157.4)	6.48 (164.5)
6, 7 & 8 (SAE 152-4)	6.49 (164.8)		
11 & 14	6.38 (162.0)	5.83 (148.0)	5.83 (148.0)
24 & 30	8.14 (206.7)	7.15 (181.6)	7.15 (181.6)

-B- CONTROL MTG. POSITION						
CONTROL OPTION	FIG.	PUMP ROT.	INPUT SHAFT ROTATION	PORT "A"	PORT "B"	TORQUE LIMITER ADJ.
***4"	4	CW	CCW	INLET	OUTLET	F
	2	CCW	CW	INLET	OUTLET	E
	2	CCW	CCW	OUTLET	INLET	F
	4	CW	CW	OUTLET	INLET	E

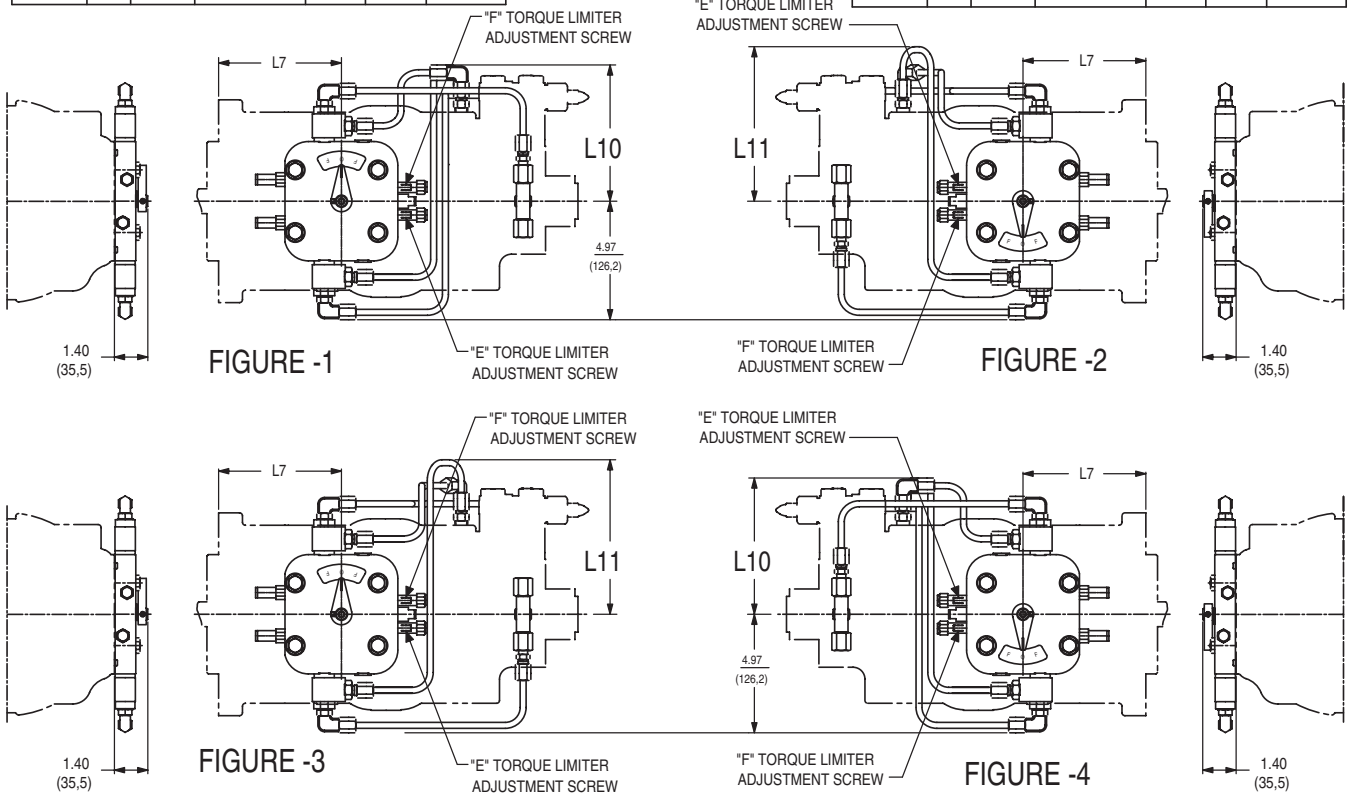

-A- CONTROL MTG. POSITION					
CONTROL OPTION	FIG.	PUMP ROT.	INPUT SHAFT ROTATION	PORT "A"	PORT "B"
***6" or ***8"	2	CW	CW	INLET	OUTLET
	2	CCW	CCW	INLET	OUTLET
	2	CW	CCW	OUTLET	INLET
	2	CCW	CW	OUTLET	INLET

-B- CONTROL MTG. POSITION					
CONTROL OPTION	FIG.	PUMP ROT.	INPUT SHAFT ROTATION	PORT "A"	PORT "B"
***6" or ***8"	1	CW	CCW	INLET	OUTLET
	1	CCW	CW	INLET	OUTLET
	1	CW	CW	OUTLET	INLET
	1	CCW	CCW	OUTLET	INLET

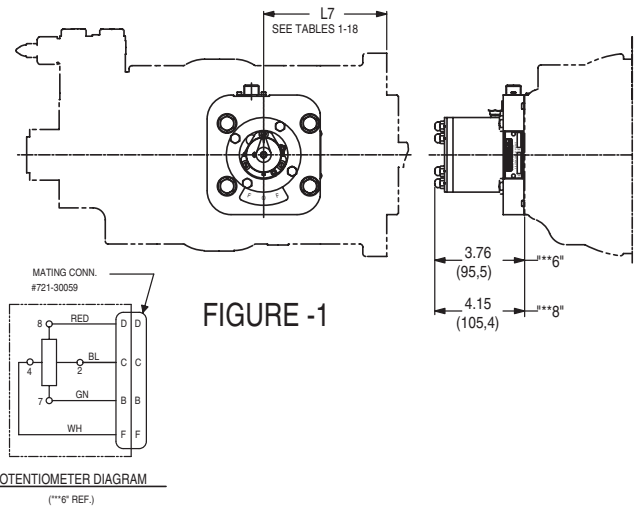
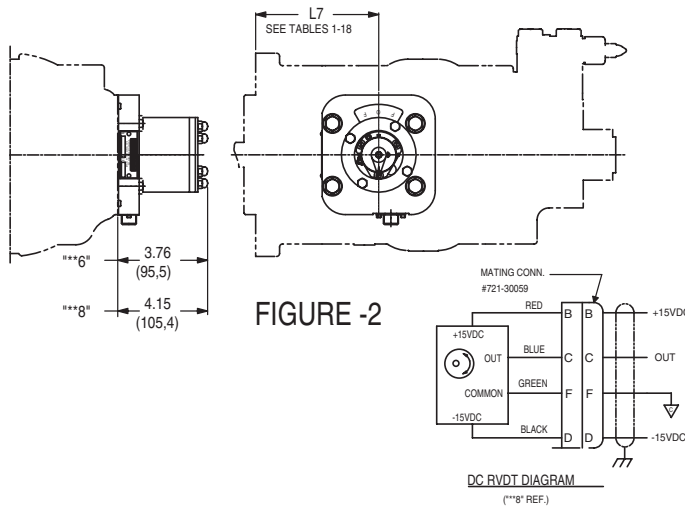

-A- CONTROL MTG. POSITION					
CONTROL OPTION	FIG.	PUMP ROT.	INPUT SHAFT ROTATION	PORT "A"	PORT "B"
***2"	2	CW	CW	INLET	OUTLET
	2	CCW	CCW	INLET	OUTLET
	2	CW	CCW	OUTLET	INLET
	2	CCW	CW	OUTLET	INLET

-B- CONTROL MTG. POSITION					
CONTROL OPTION	FIG.	PUMP ROT.	INPUT SHAFT ROTATION	PORT "A"	PORT "B"
***2"	1	CW	CCW	INLET	OUTLET
	1	CCW	CW	INLET	OUTLET
	1	CW	CW	OUTLET	INLET
	1	CCW	CCW	OUTLET	INLET

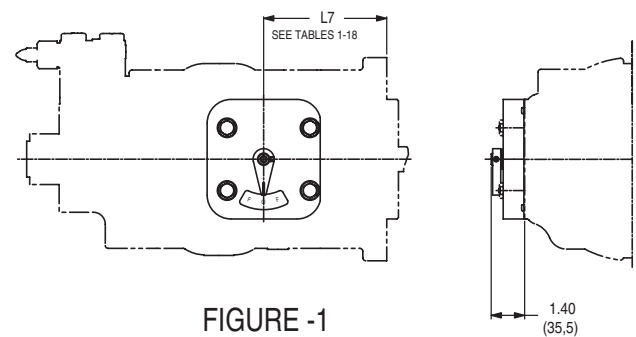
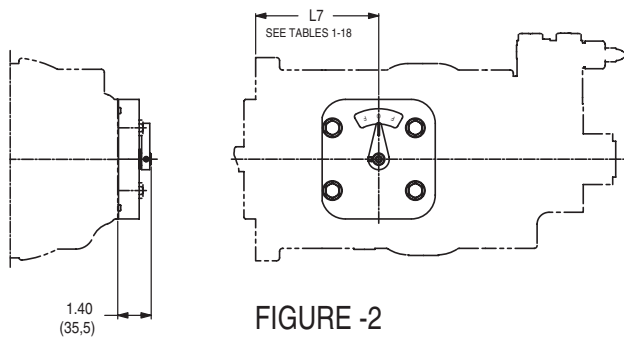

		SAE Mounting and Coupling								
Mounting	Blanking Plate	82-2 (A)	101-2 (B)	101-4 (B)	127-2 (C)	127-4 (C)	152-4 (D)	165-4 (E)	177-4 (F)	
Coupling	None	16-4 (A)	22-4 (B)	22-4 (B)	32-4 (C)	32-4 (C)	44-4 (D)	44-4 (E)	50-4 (F)	
Pumps	P6/7/8 S, X	M	A	B	-	-	-	-	-	
	P6/7/8 R, L, M	M	A	B	-	C	-	-	-	
	P11/14 S, X	M	A	B	-	-	-	-	-	
	P11/14 R, L, M	M	A	B	B	C	C	D	E	
	P24/30 S, X	-	-	B	-	C	-	-	-	
	P24/30 R, L, M	M	-	B	B	C	C	D	E	F
Motors	M6/7/8 R, L, M, N	M	A	B	-	C	-	-	-	
	M11/14 R, L, M, N	M	A	B	B	C	C	D	E	-
	M24/30 R, L, M, N	M	-	B	B	C	C	D	E	F

**P6-14 S,X**  
**SAE 82-2 (A) WITH COUPLING 16-4**  
**SAE 101-2 (B) WITH COUPLING 22-4**

NOTE:  
 1. REAR AUXILIARY UNIT TO LIMIT COUPLING TRAVEL  $\underline{.28(7.1)}$  MINIMUM FROM MOUNTING FACE ( SAE STD. REF.)

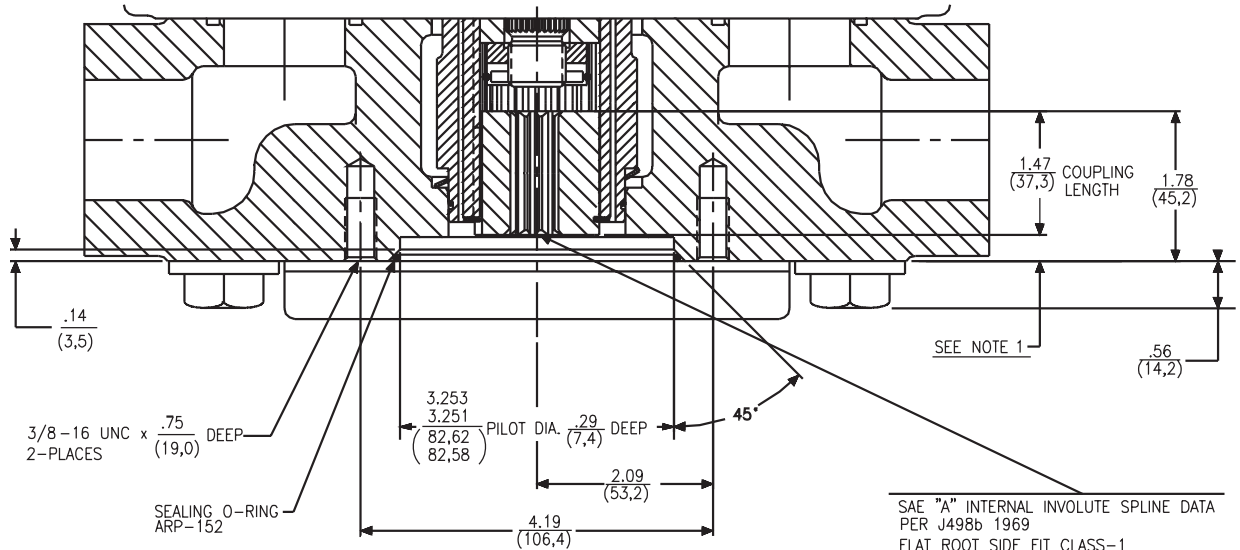

SAE "A" INTERNAL INVOLUTE SPLINE DATA  
 PER J498b 1969  
 FLAT ROOT SIDE FIT CLASS-1  
 16/32 PITCH  
 30° PRESSURE ANGLE  
 9 TEETH  
 .5139-.5089 (13,053-12,926) MINOR DIA.

**SAE 82-2 (A)**

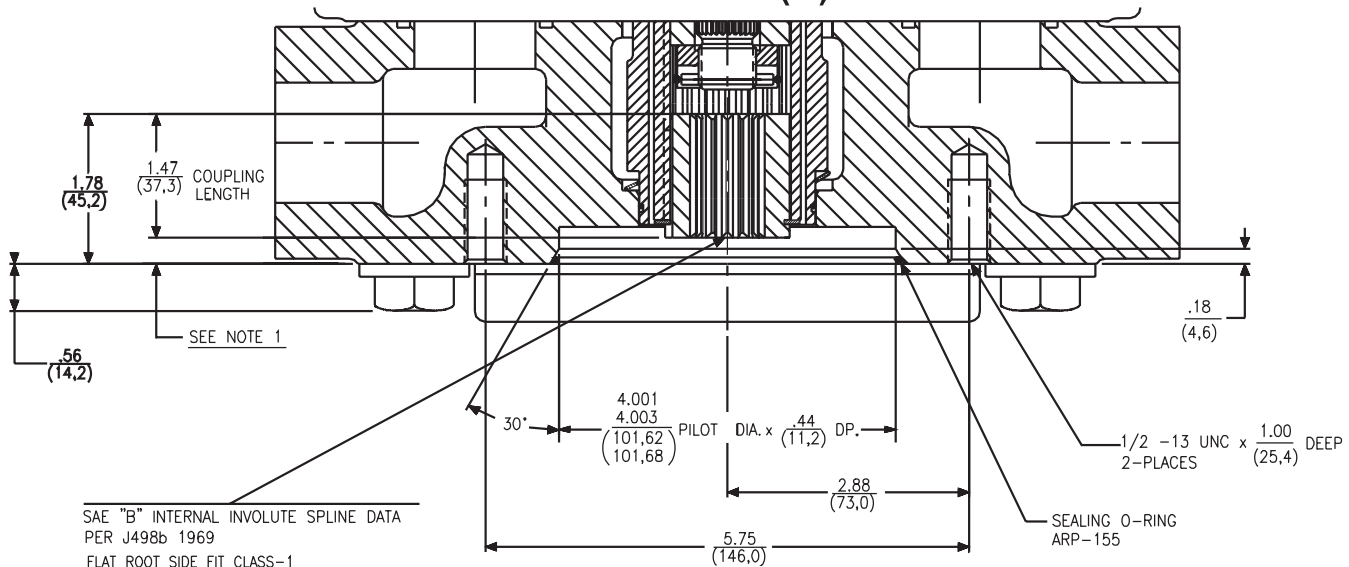

SAE "B" INTERNAL INVOLUTE SPLINE DATA  
 PER J498b 1969  
 FLAT ROOT SIDE FIT CLASS-1  
 16/32 PITCH  
 30° PRESSURE ANGLE  
 13 TEETH  
 .7583-.7533 (19,261-19,134) MINOR DIA.

**SAE 101-2 (B)**

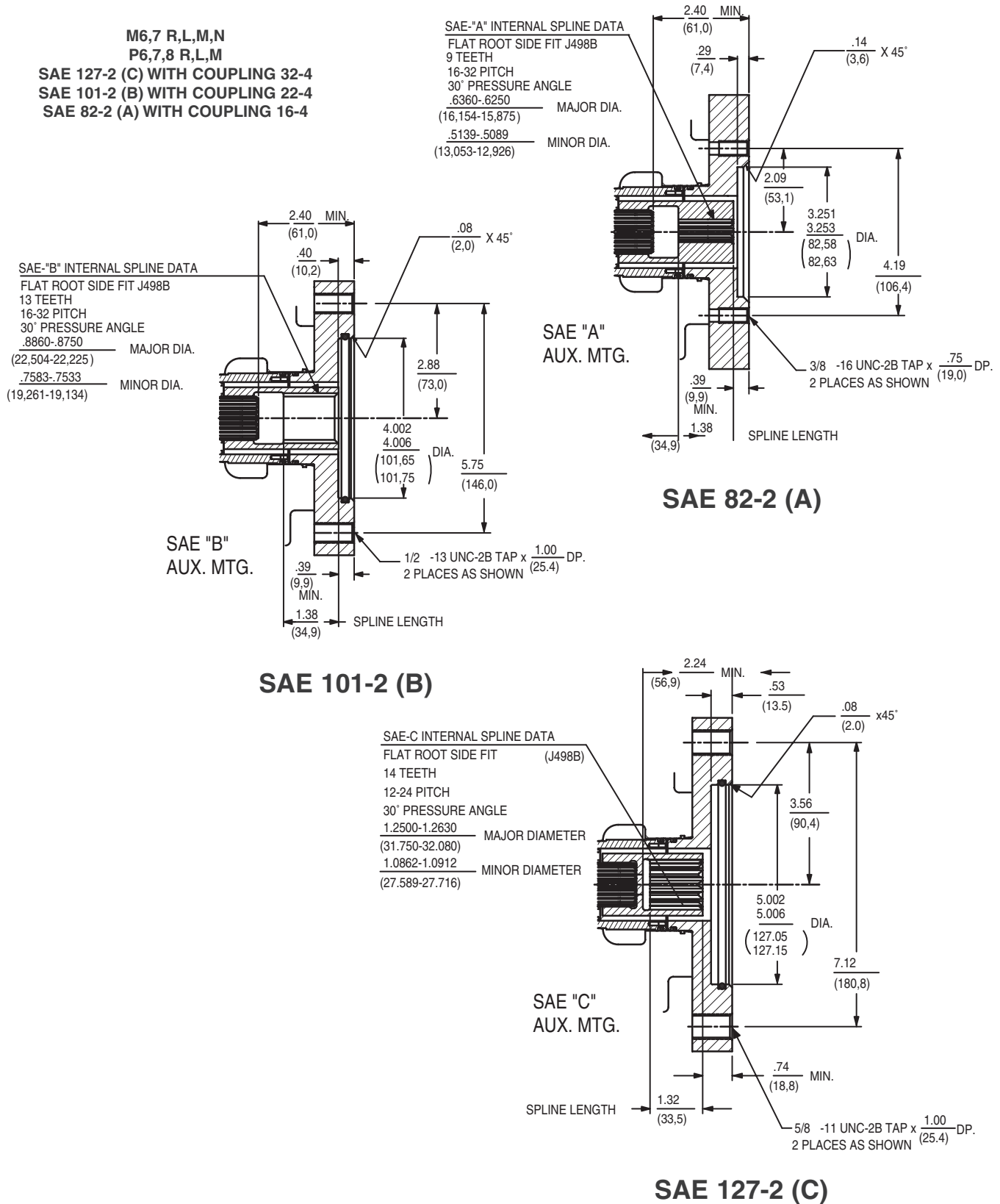



M11,14 R,L,M,N  
 P11,14 R,L  
**BLANKING PLATE**

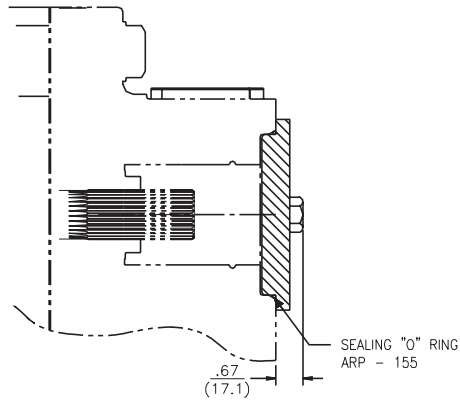

M11,14 R,L,M,N  
 P11,14 R,L,M  
**SAE 82-2 (A) WITH COUPLING 16-4**

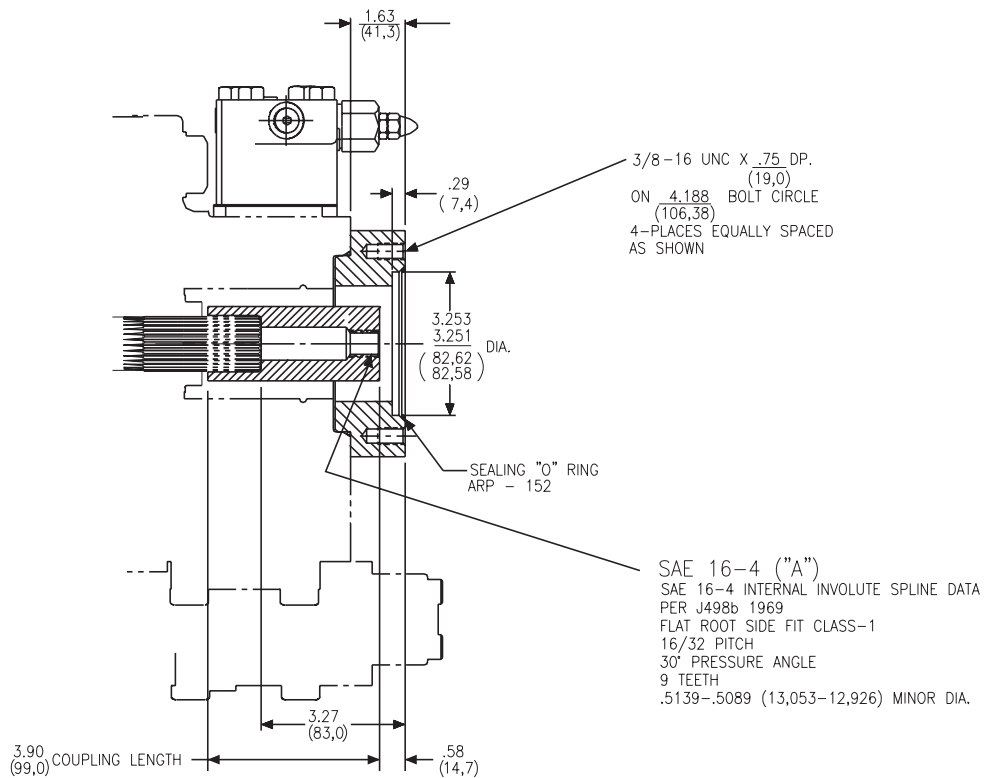

**M11,14 R,L,M,N**  
**P11,14 R,L,M**  
**SAE 101-2 (B) WITH COUPLING 22-4**  
**SAE 101-4 (B) WITH COUPLING 22-4**

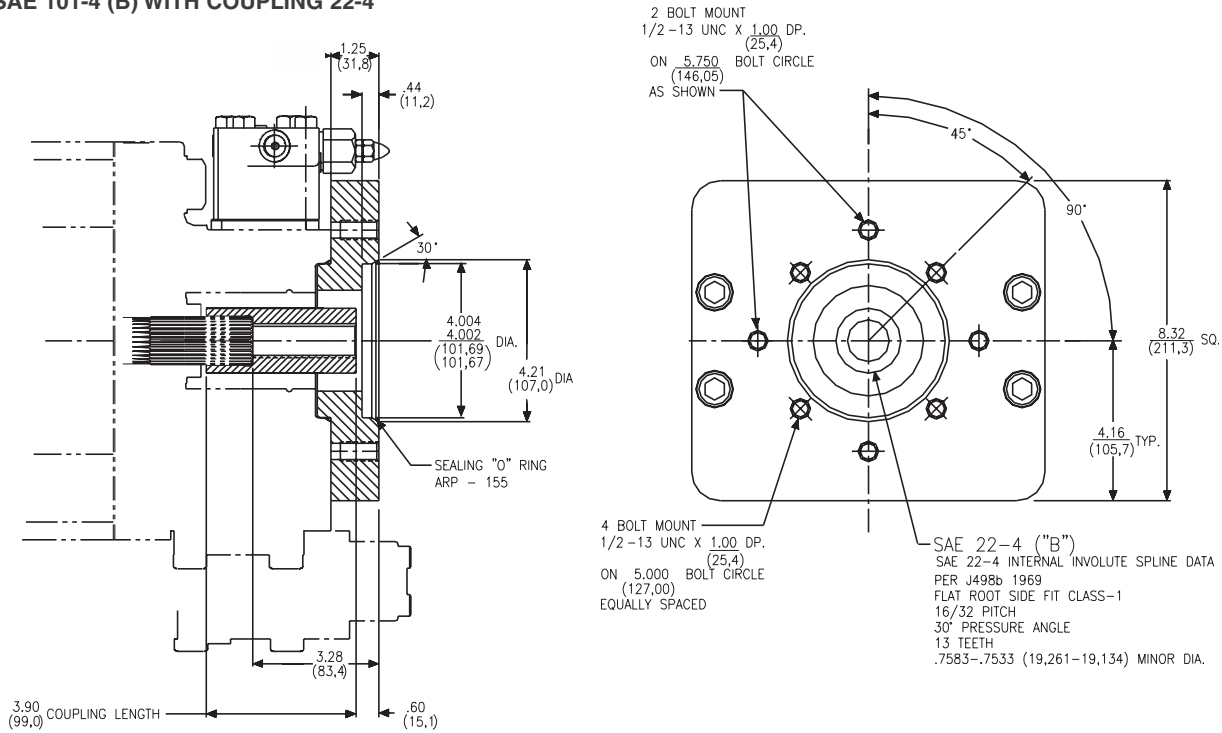

**M11,14 R,L,M,N**  
**P11,14 R,L,M**  
**SAE 127-2 (C) WITH COUPLING 32-4**  
**SAE 127-4 (C) WITH COUPLING 32-4**

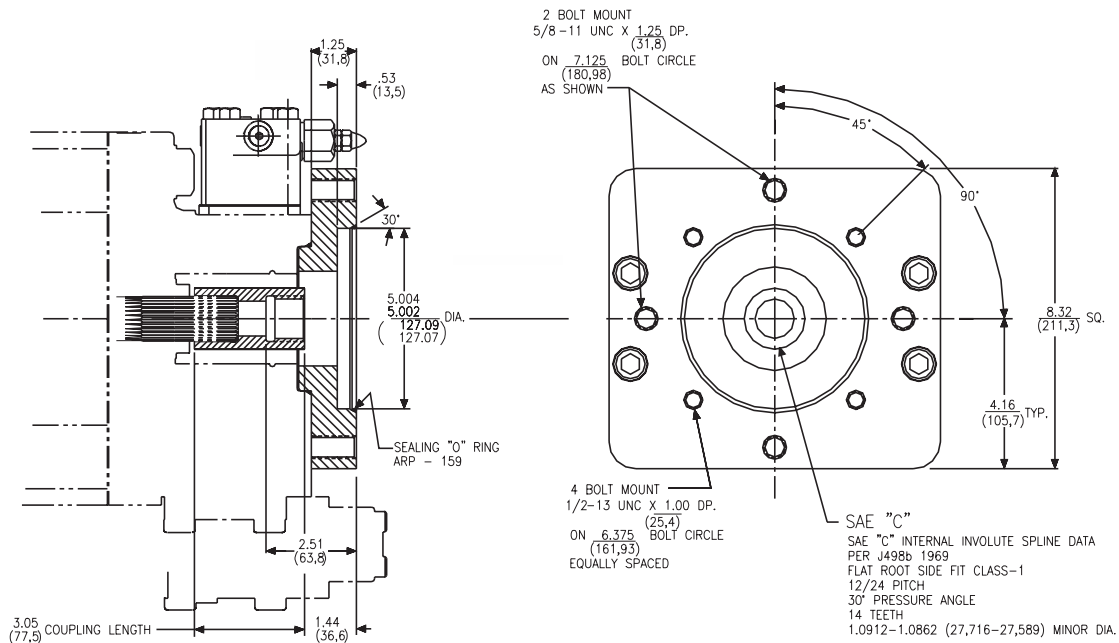

**M11,14 R,L,M,N  
P11,14 R,L,M  
SAE 152-4 (D) WITH COUPLING 44-4**

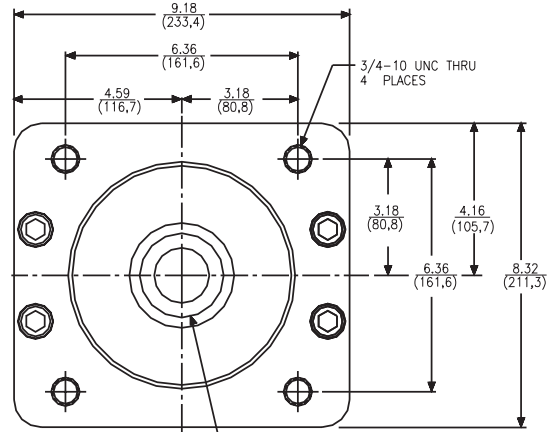
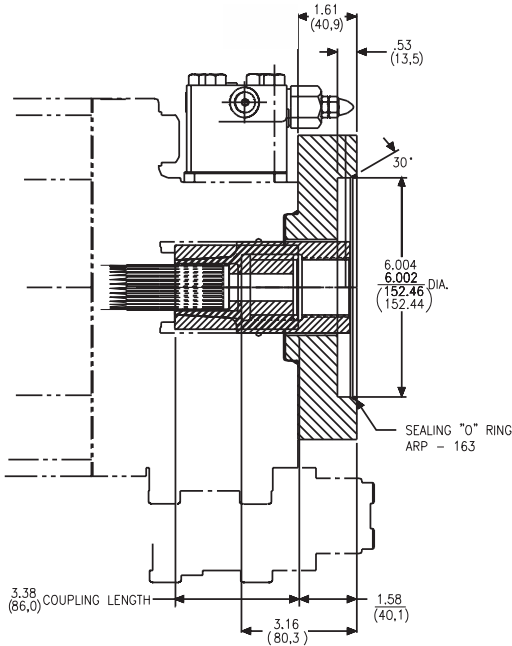

SAE "D"  
SAE "D" & "E" INTERNAL INVOLUTE SPLINE DATA  
PER J498b 1969  
FLAT ROOT SIDE FIT CLASS-1  
8/16 PITCH  
30° PRESSURE ANGLE  
13 TEETH  
1.5110-1.5060 (38,379-38,252) MINOR DIA.

**M11,14 R,L,M,N  
P11,14 R,L,M  
SAE 165-4 (E) WITH COUPLING 44-4**

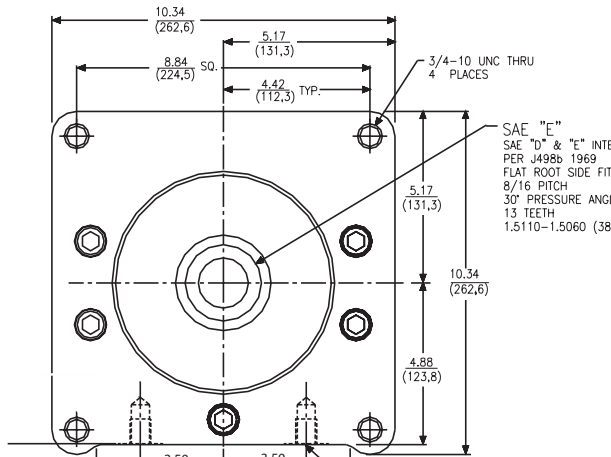
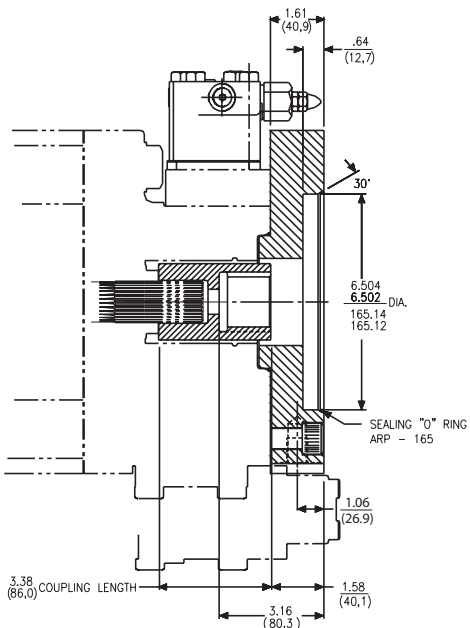

SAE "E"  
SAE "D" & "E" INTERNAL INVOLUTE SPLINE DATA  
PER J498b 1969  
FLAT ROOT SIDE FIT CLASS-1  
8/16 PITCH  
30° PRESSURE ANGLE  
13 TEETH  
1.5110-1.5060 (38,379-38,252) MINOR DIA.

OVERHUNG SUPPORT HOLES  
5/8-11 UNC x .75 DEEP  
SPOTFACE 1.34 (20.5) DIA. x DEPTH SHOWN  
2-PLACES

**P24,30,S,X**  
**SAE 101-2 (B) WITH COUPLING 22-4**

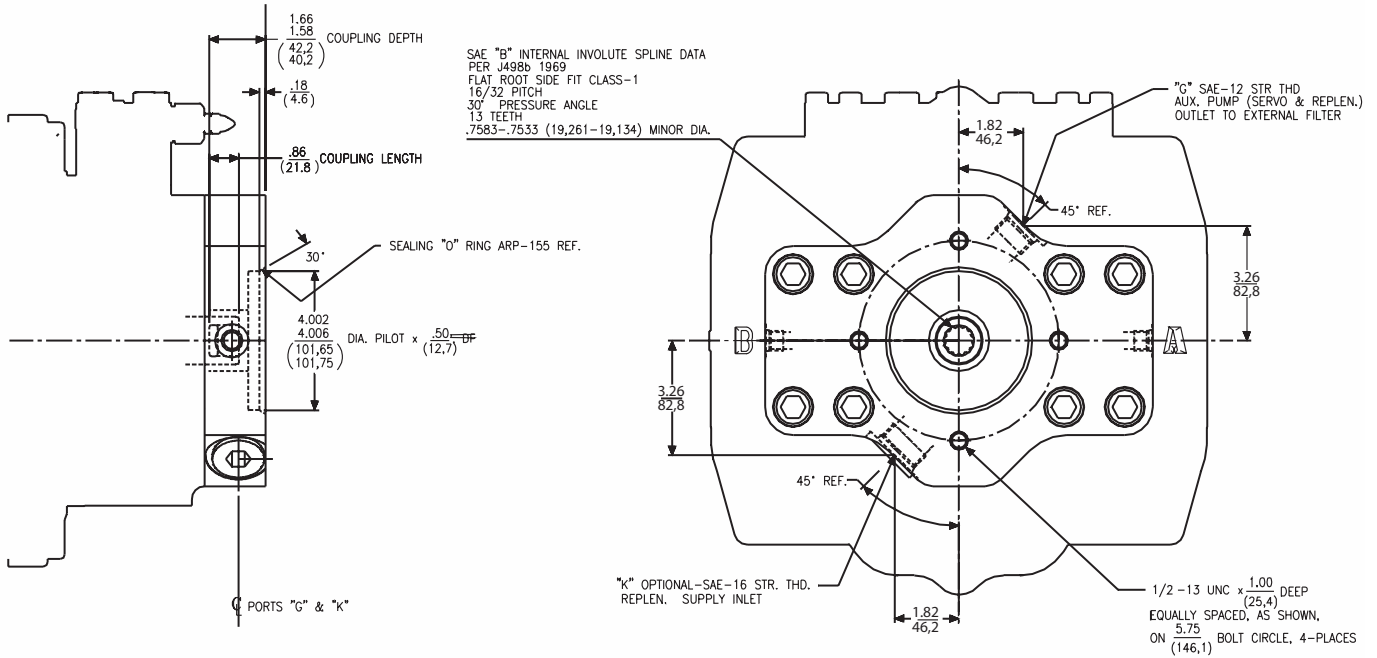

**P24,30,S,X**  
**SAE 127-2 (C) WITH COUPLING 32-4**  
**SAE 127-4 (C) WITH COUPLING 32-4**

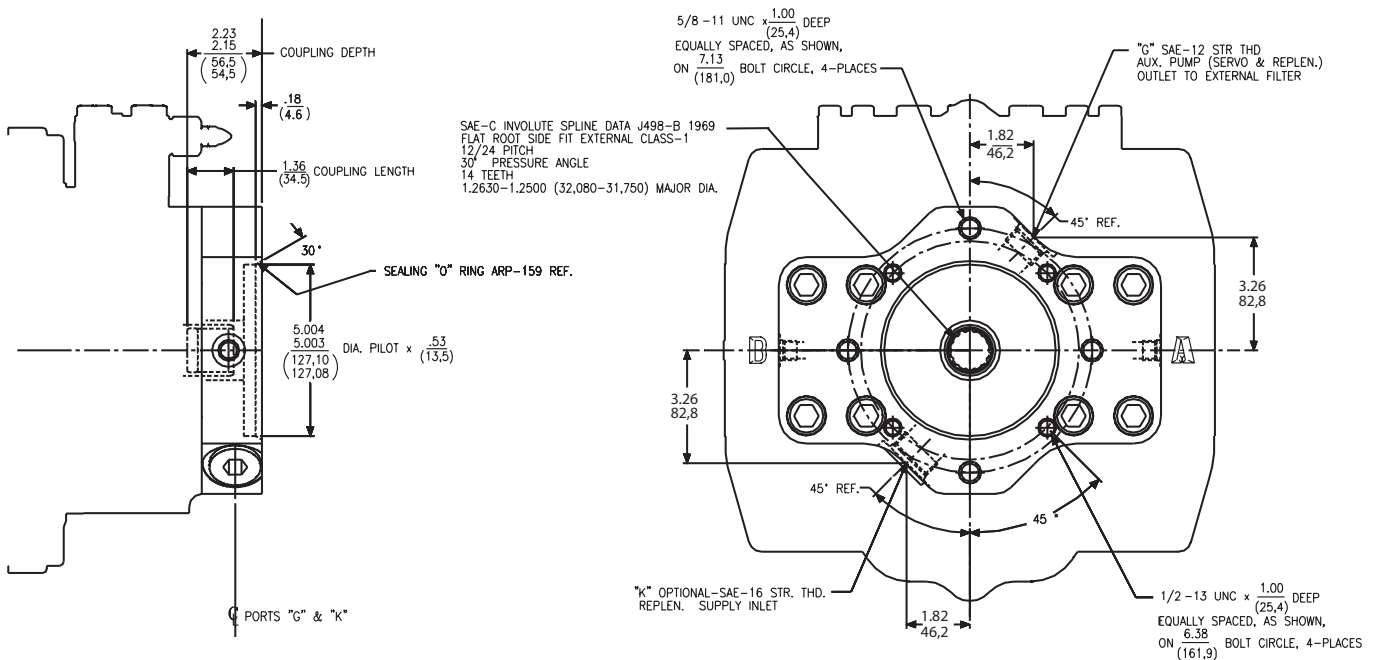

**M24,30 R,L,M,N  
P24,30 R,L,M  
BLANKING PLATE**

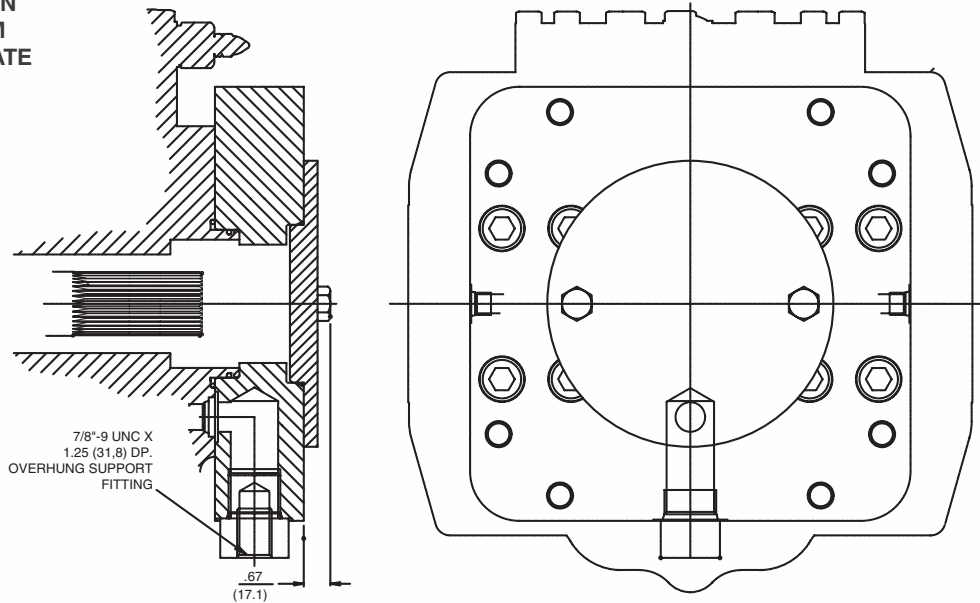

**M24,30 R,L,M,N  
P24,30 R,L,M  
SAE 101-2 (B) WITH COUPLING 22-4  
SAE 101-4 (B) WITH COUPLING 22-4**

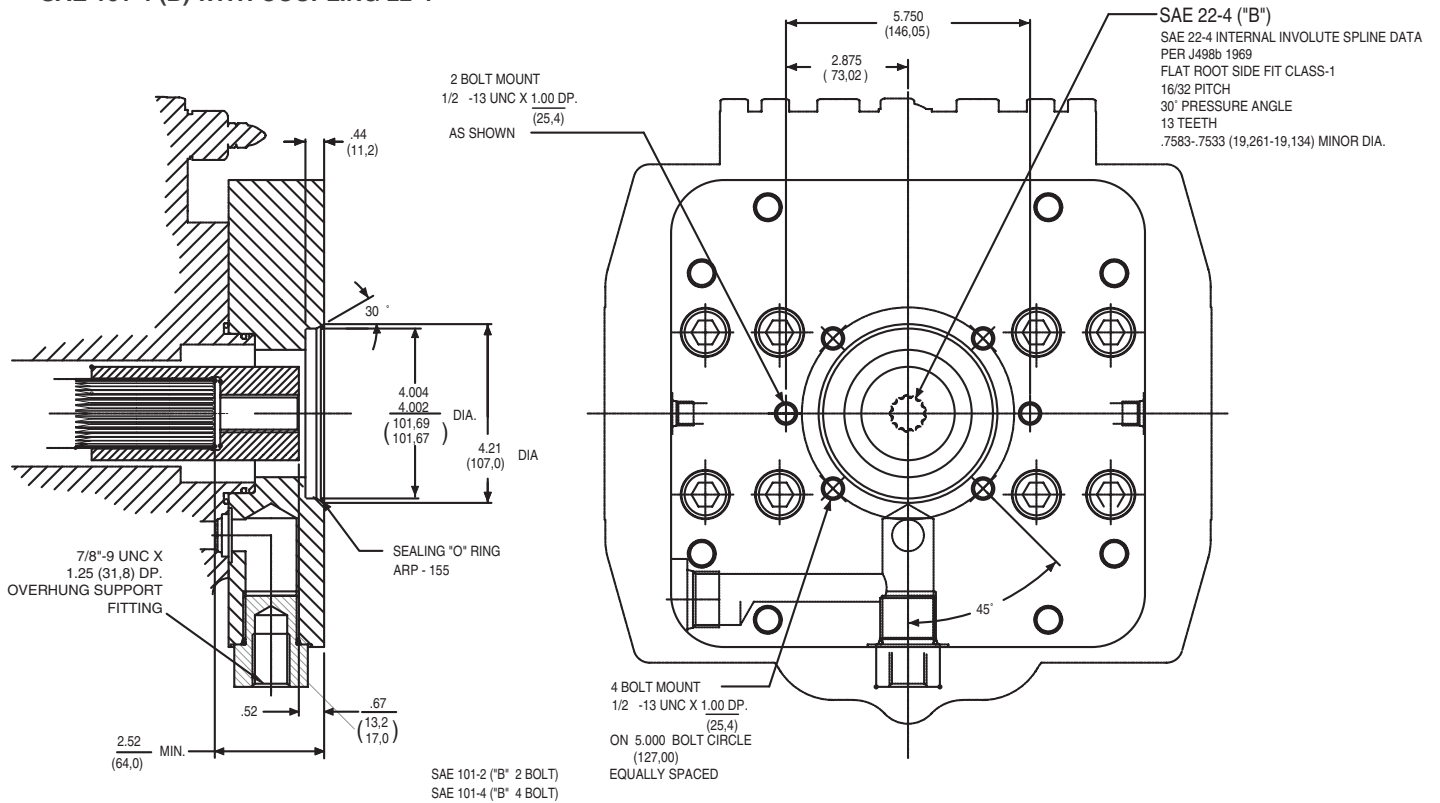

**M24,30 R,L,M,N**  
**P24,30 R,L,M**  
**SAE 127-2 (C) WITH COUPLING 32-4**  
**SAE 127-4 (C) WITH COUPLING 32-4**

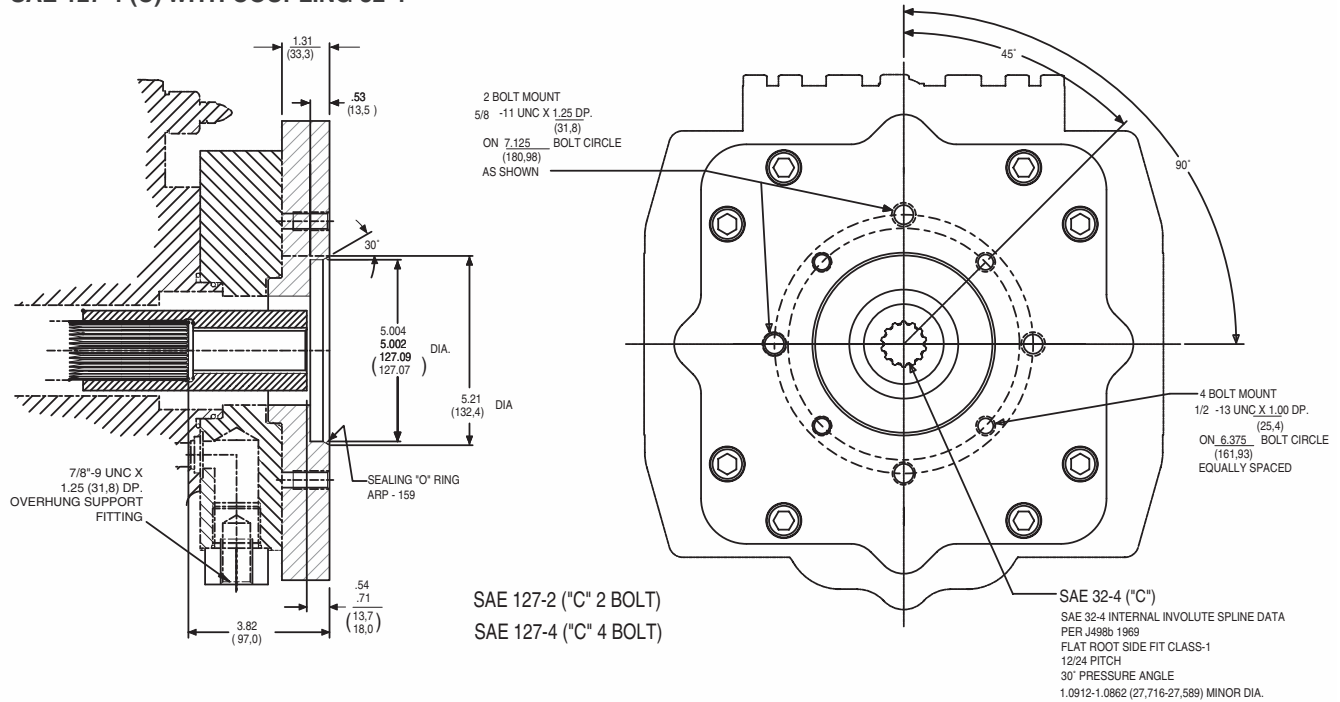

**M24,30 R,L,M,N**  
**P24,30 R,L,M**  
**SAE 152-4 (D) WITH COUPLING 44-4**

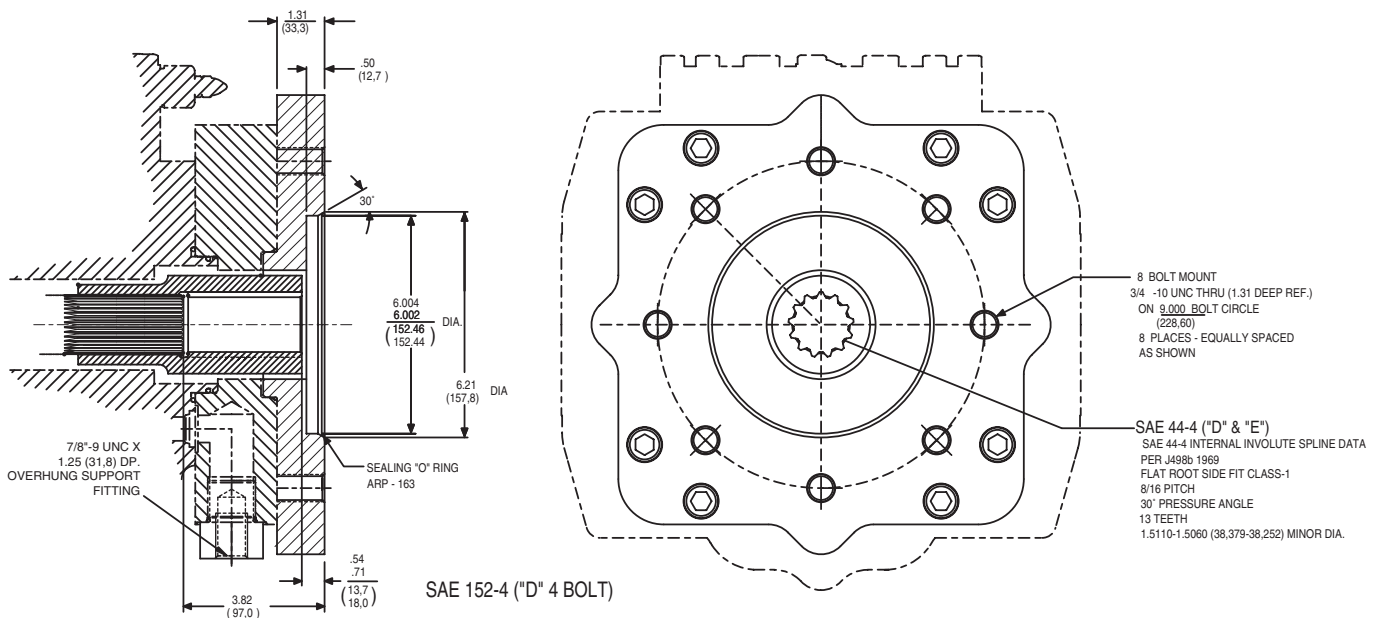

**M24,30 R,L,M,N**  
**P24,30 R,L,M**  
**SAE 165-4 (E) WITH COUPLING 44-4**

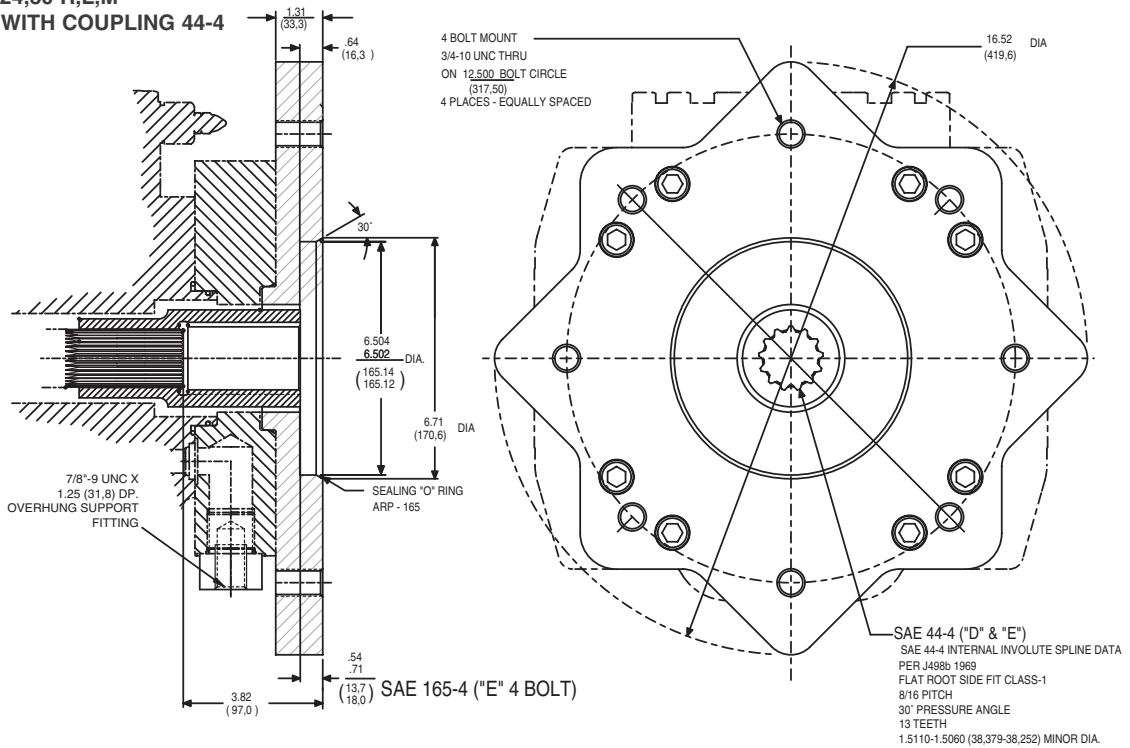

**M24,30 R,L,M,N**  
**P24,30 R,L,M**  
**SAE 177-4 (F) WITH COUPLING 50-4**

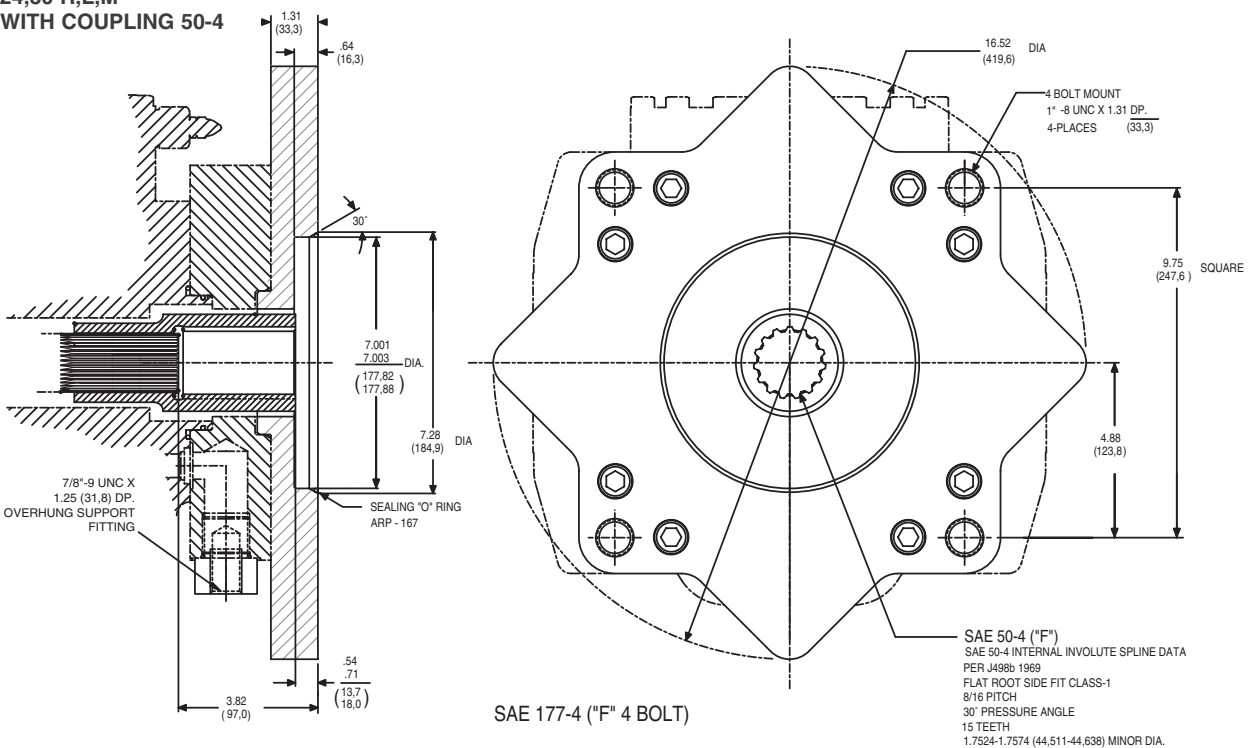

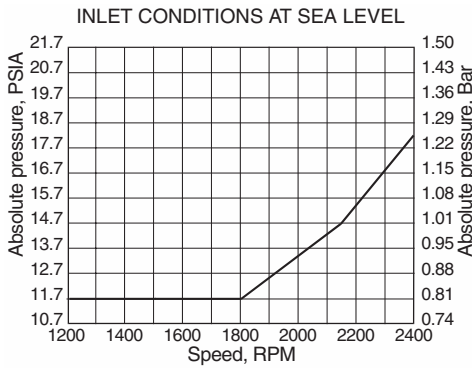

**P6V & P6F**

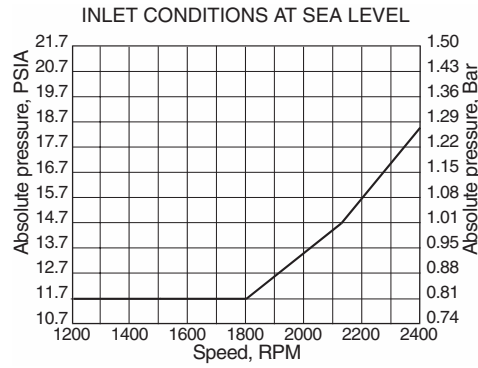

**P7V & P7F**

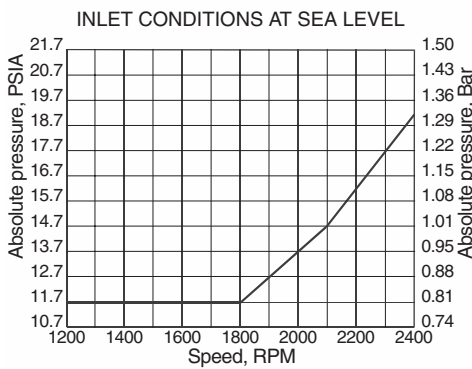

**P8V & P8F**

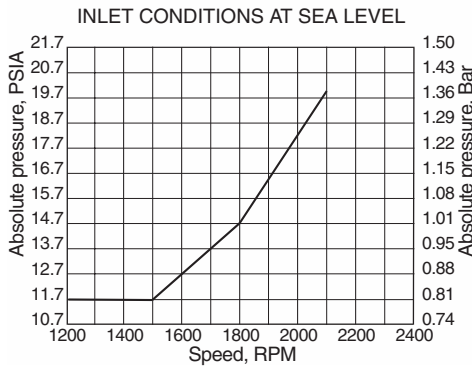

**P11V**

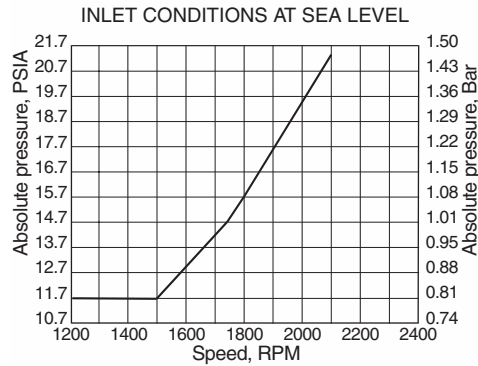

**P14V**

**Note:** The absolute inlet pressure is the pressure required to fill the pump with petroleum based fluids. The maximum pressure in the inlet port is 200 psi, 14 bar. For unboosted systems, the diameter of the suction line must be sized to allow a maximum velocity not higher than 4 ft/sec. A coarse screen may be considered in the suction line, no filter. For water in oil invert emulsions and water glycols increase the inlet absolute pressure by 25%, for phosphate ester increase the absolute inlet pressure by 35%. Any inlet pressures above atmospheric may increase noise levels and decrease efficiencies noted in this literature. Please consult your nearest Parker Office for further details.

**Inlet characteristics-auxiliary pump, port C**

Series	Speed rpm	Displacement		Pressure absolute	
		in <sup>3</sup> /rev	cm <sup>3</sup> /rev	psi	bar
6, 7, 8, 11, 14	1200	1.07	17,5	9.5	0,66
6, 7, 8, 11, 14	1800	1.07	17,5	9.5	0,66
6, 7, 8, 11, 14	2400	1.07	17,5	10.5	0,72
24, 30	1200	4.84	79,3	9.5	0,66
24, 30	1800	4.84	79,3	10.5	0,72

**Note:** Maximum pressure on inlet port C is 200 psi, 14 bar.





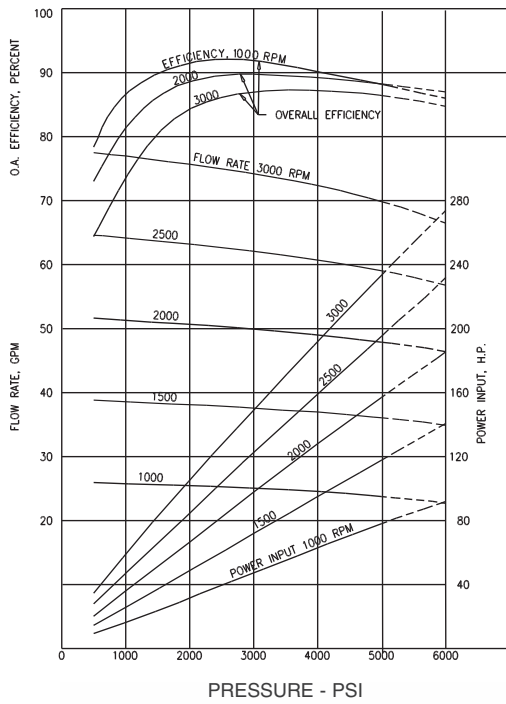

**Performance curves Series 6  
 Pump at full displacement**

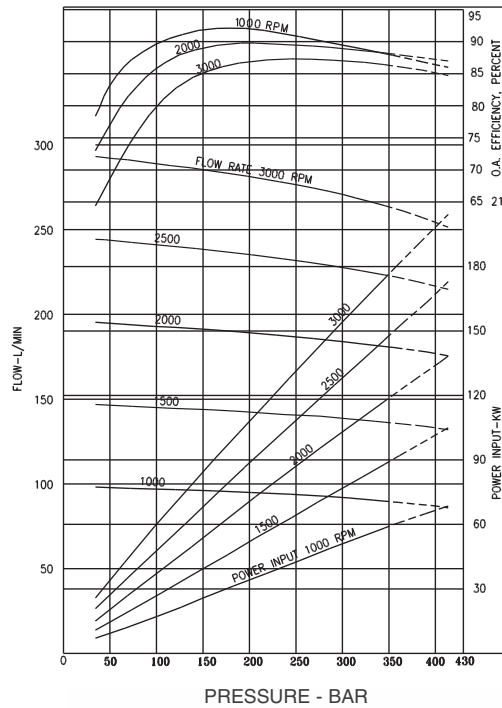

**Performance curves Series 6  
 Pump at full displacement**

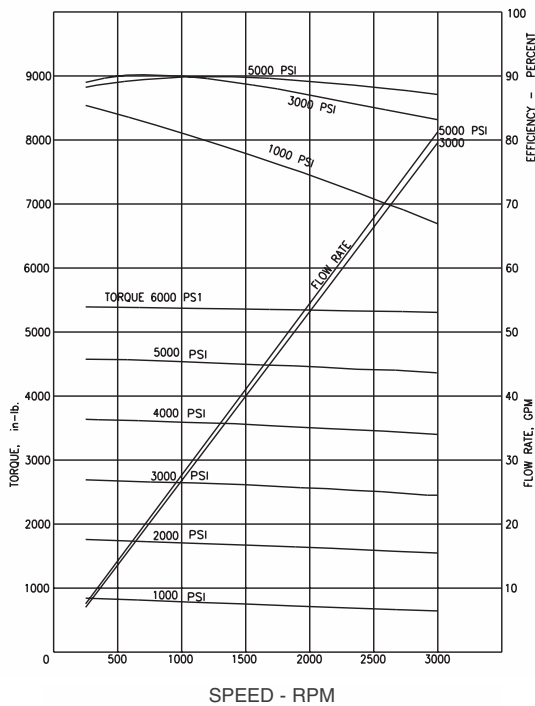

**Performance curves Series 6  
 Motor at full displacement**

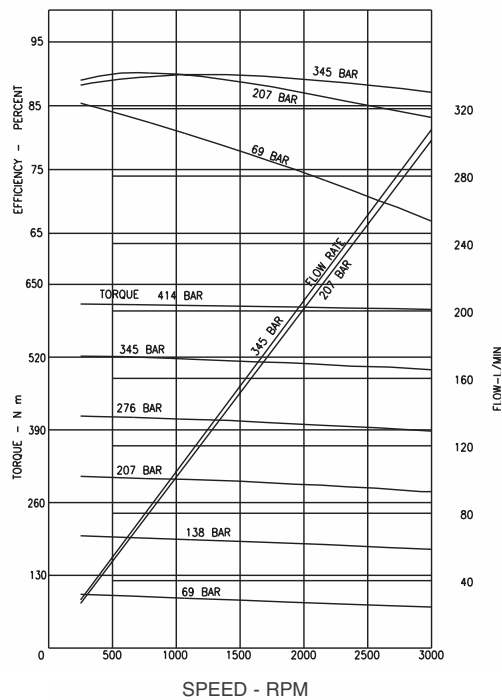

**Performance curves Series 6  
 Motor at full displacement**

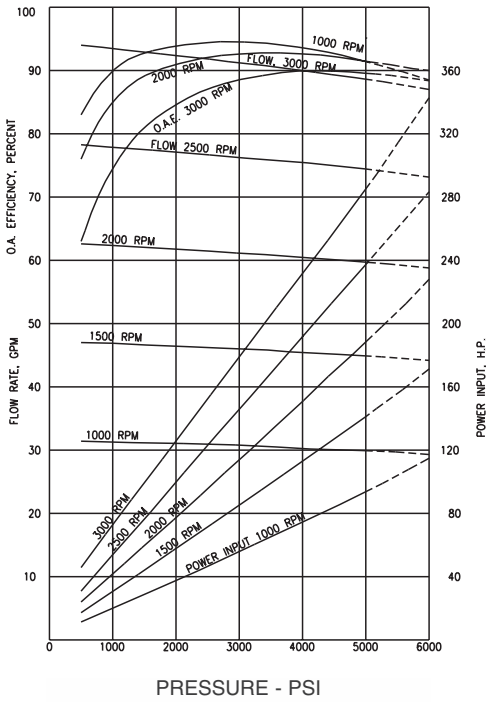

**Performance curves Series 7  
 Pump at full displacement**

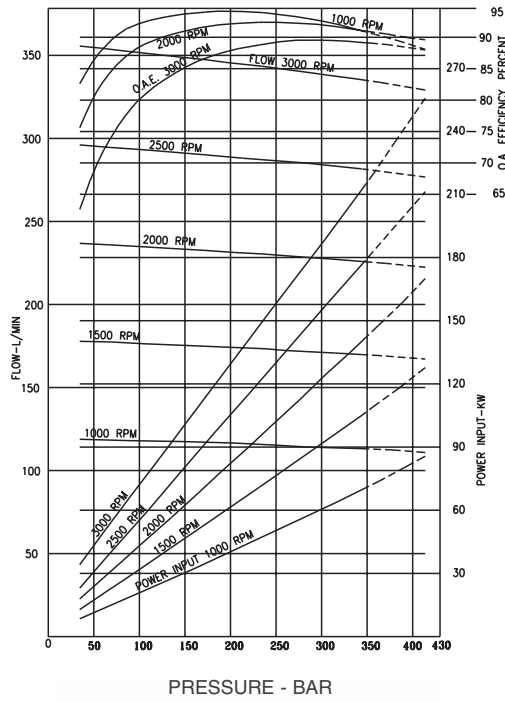

**Performance curves Series 7  
 Pump at full displacement**

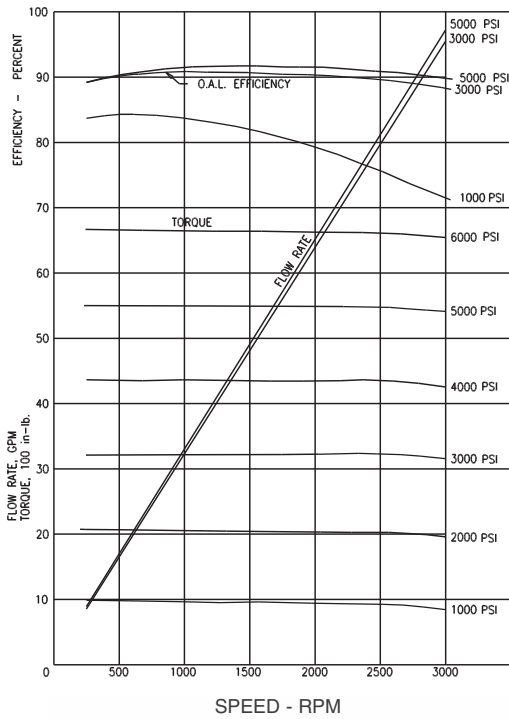

**Performance curves Series 7  
 Motor at full displacement**

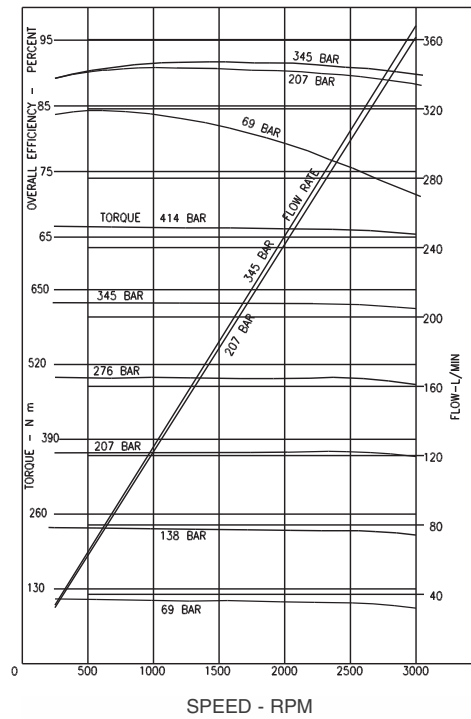

**Performance curves Series 7  
 Motor at full displacement**



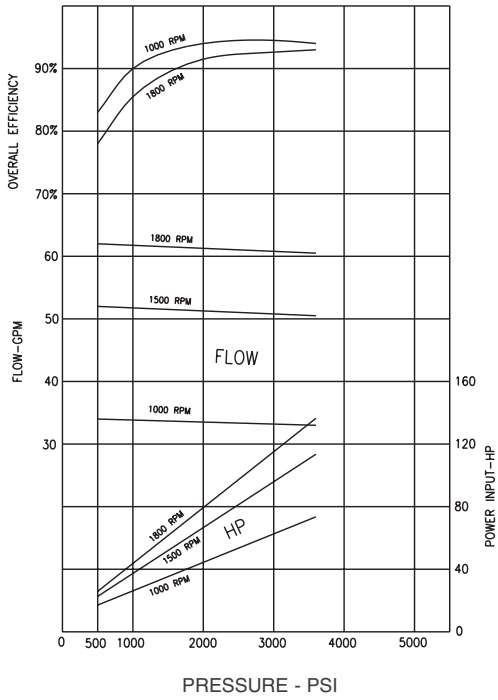

Performance curves Series 8  
 Pump at full displacement

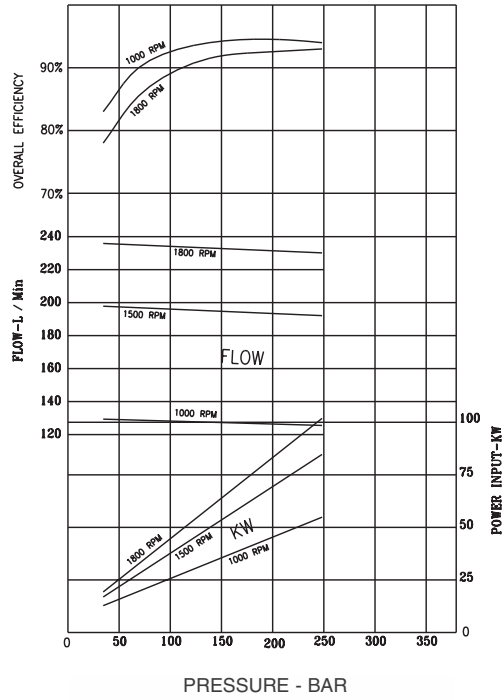

Performance curves Series 8  
 Pump at full displacement

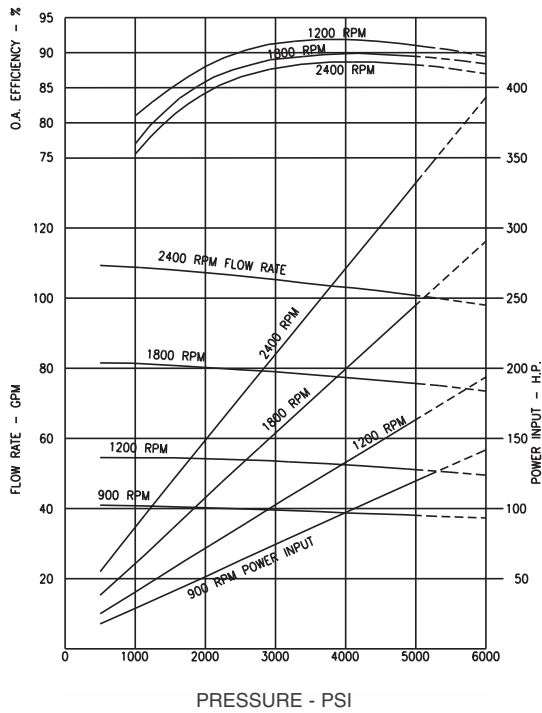

Performance curves Series 11  
Pump at full displacement

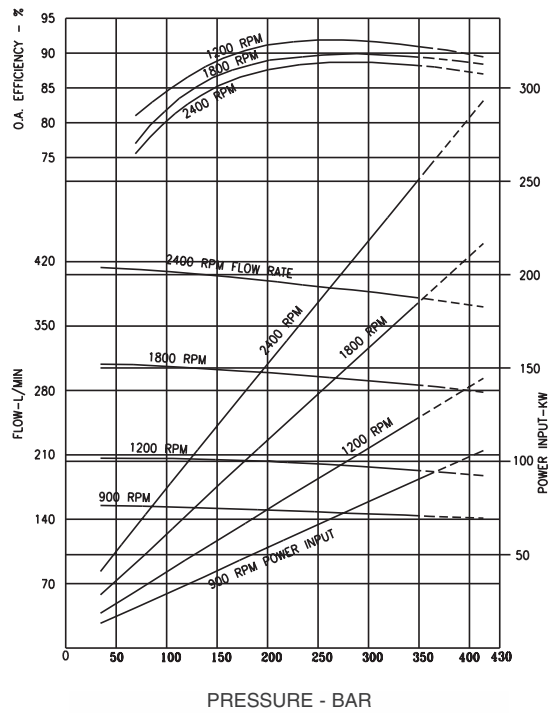

Performance curves Series 11  
Pump at full displacement

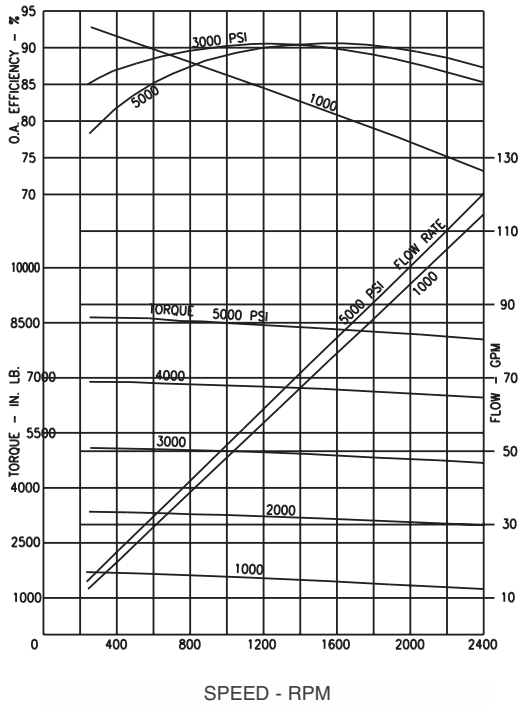

Performance curves Series 11  
Motor at full displacement

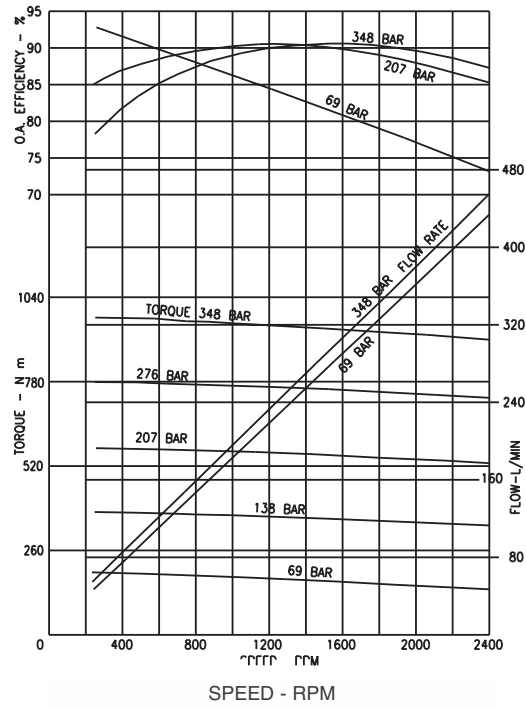

Performance curves Series 11  
Motor at full displacement



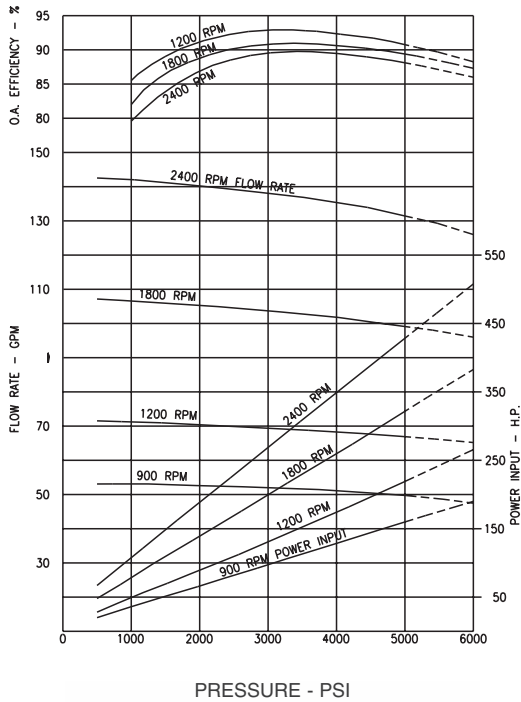

**Performance curves Series 14  
 Pump at full displacement**

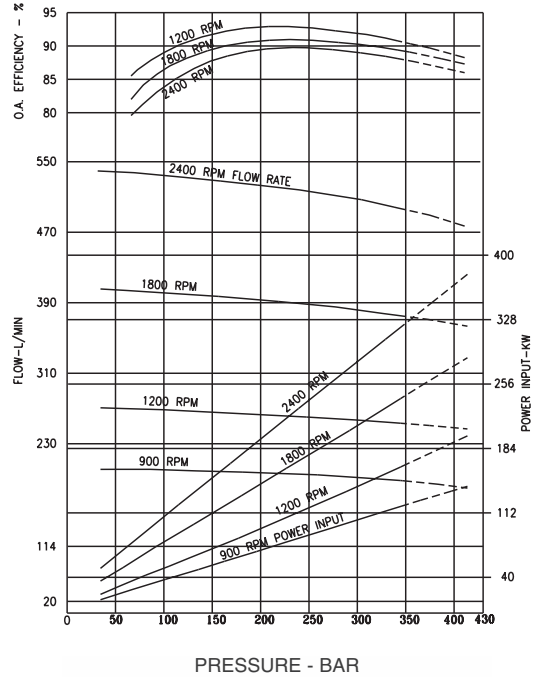

**Performance curves Series 14  
 Pump at full displacement**

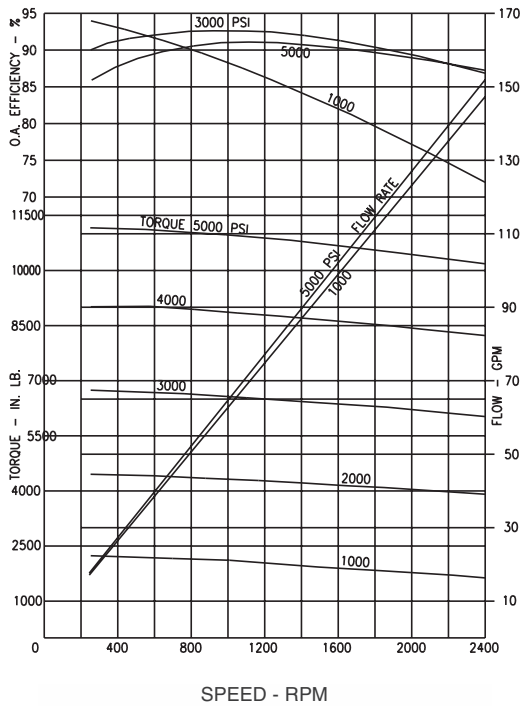

**Performance curves Series 14  
 Motor at full displacement**

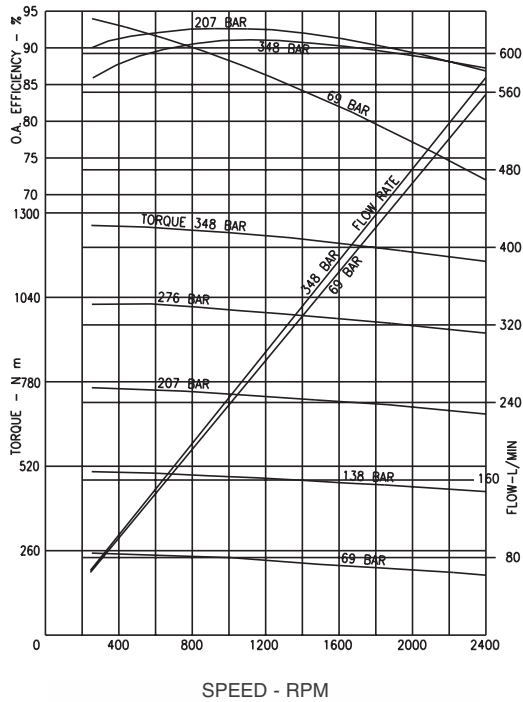

**Performance curves Series 14  
 Motor at full displacement**

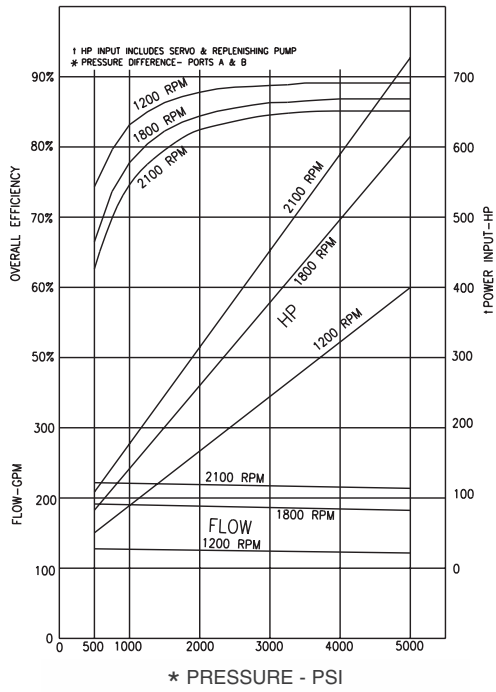

**Performance curves Series 24  
 Pump at full displacement**

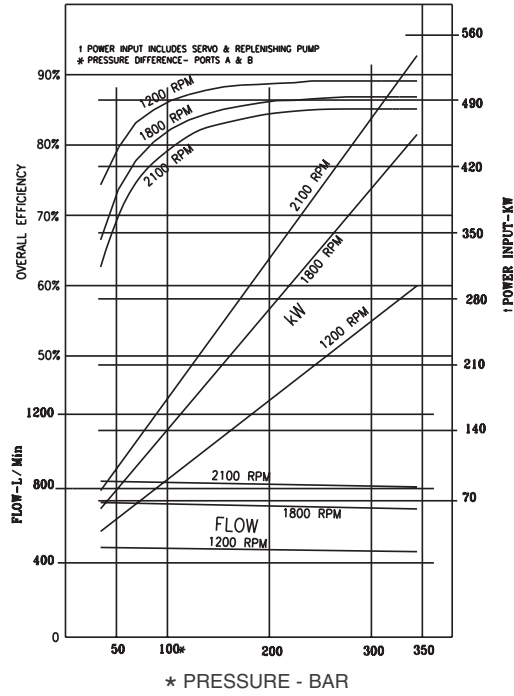

**Performance curves Series 24  
 Pump at full displacement**

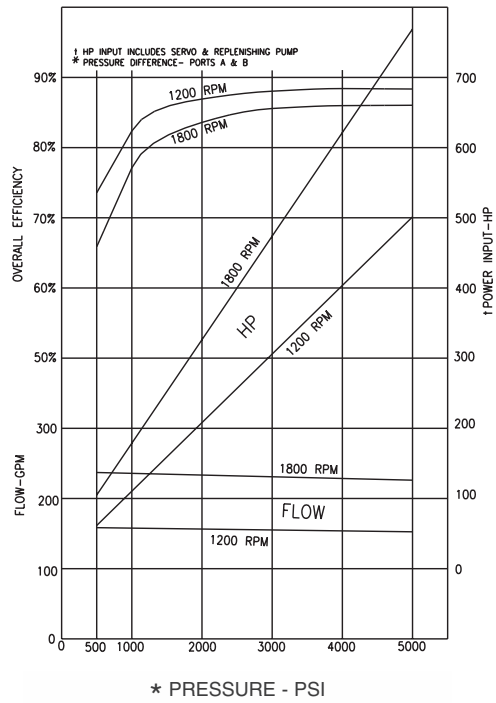

**Performance curves Series 30  
 Pump at full displacement**

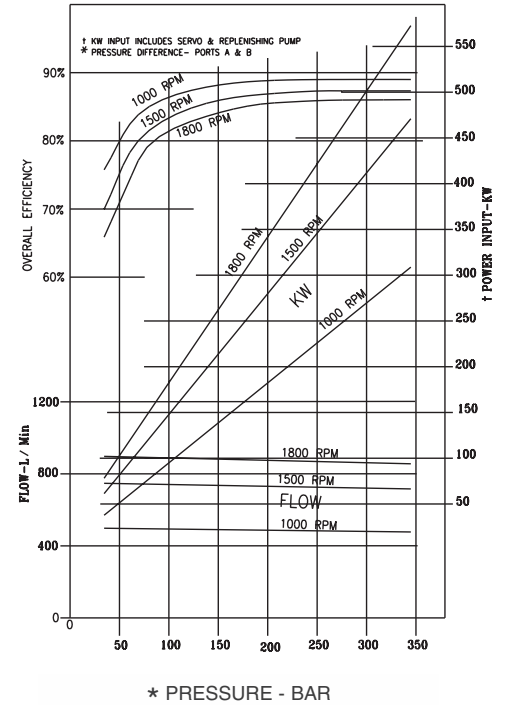

**Performance curves Series 30  
 Pump at full displacement**

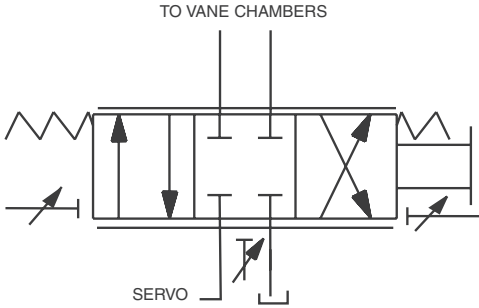
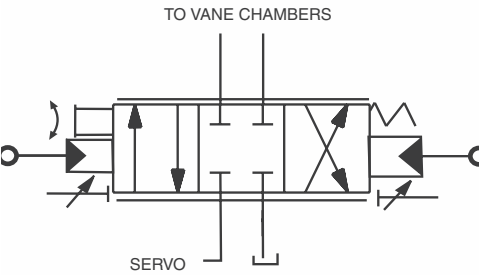
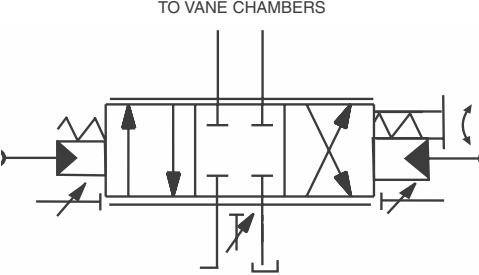
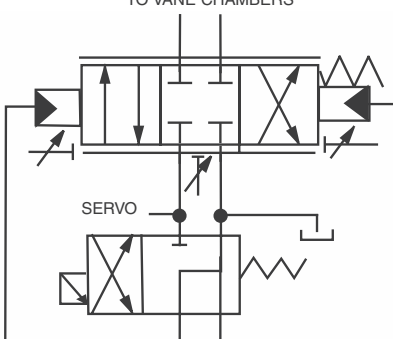

CODE	DESCRIPTION	HYDRAULIC CIRCUIT
10	MANUAL SCREW ADJUST	
2A	TWO POSITION CONTROL	
2H	3 POSITION CONTROL	
2M	2 POSITION CONTROL WITH CEPTOP3, NG6 VALVE	

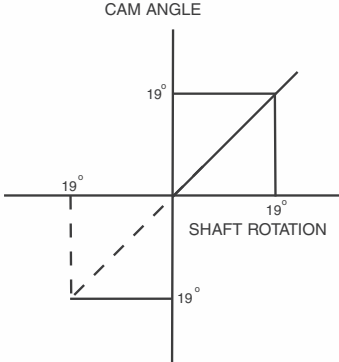
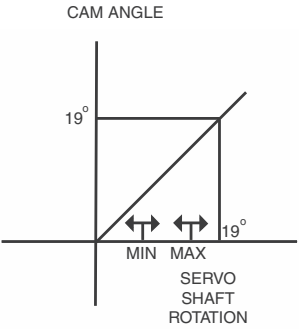
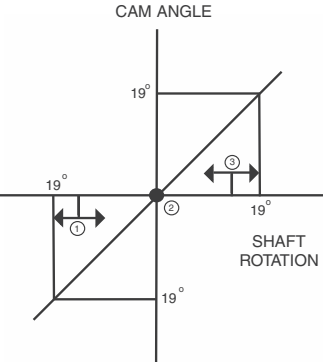
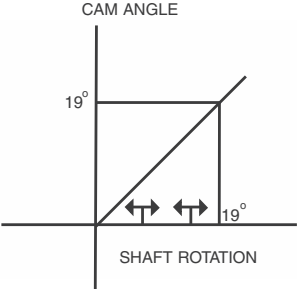
TYPICAL PERFORMANCE	DESCRIPTION OF OPERATION
	<p>Spring loaded toward maximum displacement, with an adjustment screw to limit the displacement anywhere between 0% and 100%. A minimum volume stop is also supplied so that when the rotary servo shaft is turned, the displacement can be varied only between the minimum and maximum settings.</p> <p>Torque required to rotate servo shaft: 20 lb-in, 2.56 Nm.</p>
	<p>Hydraulically piloted non-proportionally between adjustable minimum and maximum displacements. The control is spring loaded toward minimum when used on pumps, to maximum on motors. Servo pressure is switched by an external valve to drive the control in either direction. When used on motors, the minimum setting can be set no lower than 30% of maximum.</p>
	<p>Hydraulically piloted non-proportionally between an adjustable minimum displacement of <math>0 \pm 5\%</math> and two fully adjustable maximum displacements, one in either direction, and spring loaded toward minimum. Servo pressure is switched by an external valve to drive the control in either direction.</p>
	<p>Same as 2A except a CEPTOP3, NG6 two position directional valve is mounted to the control. With the solenoid de-energized, the control is spring loaded to zero for pumps and to maximum displacement for motors. Energizing the solenoid drives the control toward maximum displacement on pumps, minimum on motors. When used on motors, the minimum settings can be no less than 30% of maximum.</p>

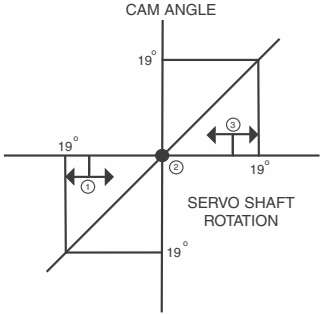
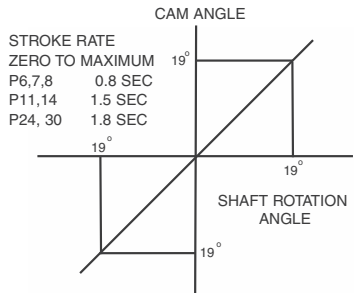
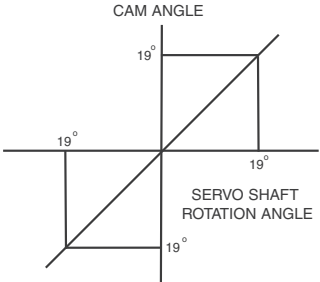
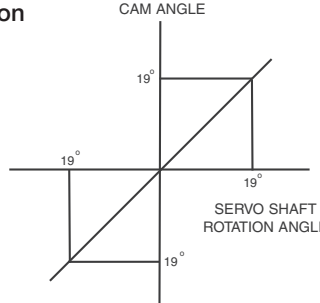
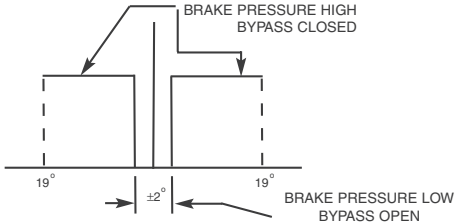

<p>2N</p>	<p><b>3 POSITION CONTROL WITH CEPTOP3, NG6 VALVE</b></p>	
<p>40</p>	<p><b>SPRING CENTERED ROTARY SERVO</b></p>	
<p>4A</p>	<p><b>SPRING CENTERED ROTARY SERVO WITH ADJUSTABLE STOPS</b></p>	
<p>4B</p>	<p><b>SPRING CENTERED ROTARY SERVO WITH AUTOMATIC BRAKE AND BYPASS CONTROL</b></p>	

TYPICAL PERFORMANCE	DESCRIPTION OF OPERATION
	<p>Same as 2H except a CEPTOP3, NG6 three position directional valve is mounted to the control. With the solenoids de-energized, the control is spring loaded to zero. Energizing a solenoid drives the control toward maximum displacement in one of the two directions.</p>
	<p>The 40 is the basic displacement control for all Goldcup. It is actuated by a servo shaft that is rotated from 0° - 19°, either side of center. This action opens a unique slide valve to port servo oil to and from the vane chambers that actuate the rocker cam. Vanes, integral to the cam, move the cam so that it follows the rotary servo input shaft motion exactly. When the cam reaches the position equal to that of the input shaft, the slide valve closes. Any cam motion due to pumping forces immediately opens the slide valve to correct the cam position.</p> <p>Springs cause the control to return to zero stroke when no external force is applied to the servo shaft. An adjustment is provided to locate the exact zero position, to prevent machine creep.</p>
	<p>The 4A control is the same as the 40, with addition of adjustable maximum volume stop screws, with locking caps, to limit the control to less than 100% displacement. Stops are present on both sides of center and may be set independently to different settings.</p>
<p>The 4B control is the same as the 4A control, with the addition of an output port that will provide servo pressure to control a spring applied, pressure released parking brake. The control contains anticoincidence functions that cause the brake to release immediately upon</p> 	<p>application of an on-stroke motion at the rotary servo shaft, and that cause the brake to remain released even after the rotary servo shaft is recentered, until the pump rocker cam actually returns to zero, at which time the brake will set. Additionally, a small bypass is opened between the pump A &amp; B ports to bypass any flow that is generated if the pump is not exactly zeroed. The bypass closes whenever the brake is released.</p> 

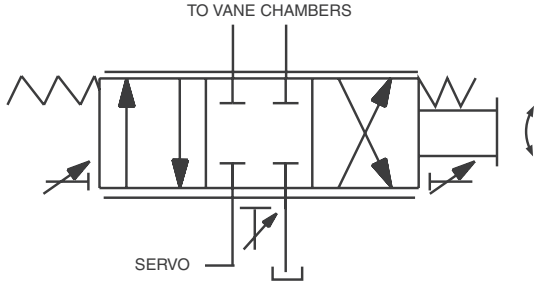
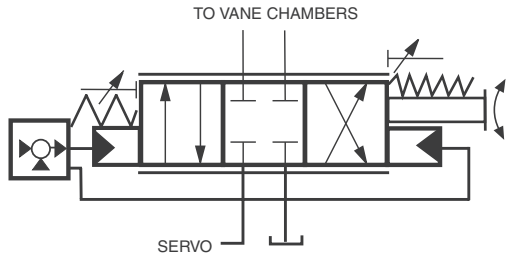
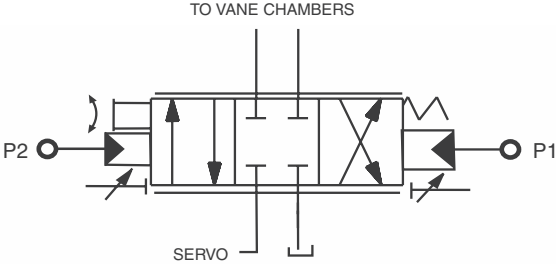
CODE	DESCRIPTION	HYDRAULIC CIRCUIT
4C	<p><b>SPRING CENTERED BRAKE AND ADJUSTABLE BYPASS CONTROL (AUTOMATIC BRAKE CONTROL)</b></p>	
5A	<p><b>ELECTROHYDRAULIC CONTROL</b></p>	
8A	<p><b>HYDRAULIC STROKER</b></p>	

TYPICAL PERFORMANCE	DESCRIPTION OF OPERATION
	<p>This control combines the features of the 4A and 4B controls. See above descriptions.</p>
	<p>The 5A control controls displacement in proportion to an electric current between zero and 350 milliamps. The control is available with or without a 10% deadband. Positive polarity drives the control in one direction, and negative polarity in the other. Adjustable maximum displacement stops are included. The 5C option, with automatic brake control, is also available.</p>
	<p>The 8A control controls displacement in proportion to a hydraulic pressure, values listed below. Pressure applied in the P1 port drives the pump on stroke in one direction, P2 port in the other. Adjustable maximum displacement stops are included. The 8C option, with automatic brake control, is also available.</p>

CODE	DESCRIPTION	HYDRAULIC CIRCUIT
9A	ELECTRIC STROKER	
7D6 7D8 7F6 7F8	HIGH IQ SERVOVALVE CONTROL	

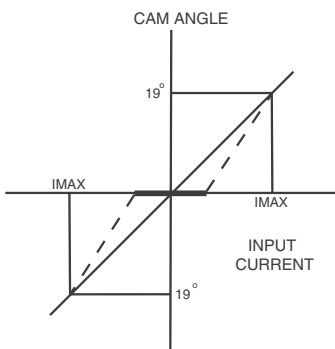
TYPICAL PERFORMANCE	DESCRIPTION OF OPERATION																																		
	<p>The 9A control controls displacement in proportion to an electric current between zero and 350 milliamps for the 24 volt version, and up to 650 milliamps for the 12 volt version. The control signal is a Pulse Width Modulated signal. Current signal to one coil drives the pump in one direction, and to the other coil in the opposite. Adjustable maximum displacement stops are included. The 9C option, with automatic brake control, is also available.</p> <table border="1" data-bbox="630 514 1380 997"> <thead> <tr> <th colspan="2">Specifications:</th> </tr> </thead> <tbody> <tr> <td>Hysteresis</td> <td>5% typical, 8% maximum</td> </tr> <tr> <td>Linearity</td> <td>8%</td> </tr> <tr> <td>Response</td> <td>P6,7,8      0.9 seconds, zero to full stroke or back P11,14      1.5 seconds, zero to full stroke or back P24, 30      1.8 seconds, zero to full stroke or back</td> </tr> <tr> <td>Repeatability</td> <td>2%</td> </tr> <tr> <td>Temperature null shift</td> <td>&lt;2% per 100°F (38° C)</td> </tr> <tr> <td>Servo pressure required</td> <td>200-1000 psi (14-70 bar), 400 nominal (28 bar)</td> </tr> <tr> <td>Coil resistance</td> <td>41 ohms (24v coil) &amp; 10 ohms (12v coil)</td> </tr> <tr> <td>Electrical input*</td> <td>270 ma minimum, 325 ma nominal, 380 ma maximum (24v coil)</td> </tr> <tr> <td>Neutral deadband*</td> <td>150 ma minimum, 180 ma nominal, 210 ma maximum (24v coil)</td> </tr> <tr> <td>Manual override</td> <td>3/16" Allen wrench, 30 in-lb (3.4Nm) with zero signal</td> </tr> <tr> <td>Fluid types</td> <td>All</td> </tr> <tr> <td>Available open-loop drivers</td> <td>Jupiter 900 card      S20-14078 Dual Driver module      027-22071-0</td> </tr> <tr> <td></td> <td>Power supply      762-30026-0</td> </tr> <tr> <td></td> <td>Euro card holder      EX00-S07</td> </tr> <tr> <td>Electrical connector</td> <td>DIN 43650 type AF, 16-01008-8</td> </tr> <tr> <td>Fluid cleanliness</td> <td>NAS 1638, class 8 or ISO 17/14</td> </tr> </tbody> </table> <p>* 12V coils are twice these values</p>	Specifications:		Hysteresis	5% typical, 8% maximum	Linearity	8%	Response	P6,7,8      0.9 seconds, zero to full stroke or back P11,14      1.5 seconds, zero to full stroke or back P24, 30      1.8 seconds, zero to full stroke or back	Repeatability	2%	Temperature null shift	<2% per 100°F (38° C)	Servo pressure required	200-1000 psi (14-70 bar), 400 nominal (28 bar)	Coil resistance	41 ohms (24v coil) & 10 ohms (12v coil)	Electrical input*	270 ma minimum, 325 ma nominal, 380 ma maximum (24v coil)	Neutral deadband*	150 ma minimum, 180 ma nominal, 210 ma maximum (24v coil)	Manual override	3/16" Allen wrench, 30 in-lb (3.4Nm) with zero signal	Fluid types	All	Available open-loop drivers	Jupiter 900 card      S20-14078 Dual Driver module      027-22071-0		Power supply      762-30026-0		Euro card holder      EX00-S07	Electrical connector	DIN 43650 type AF, 16-01008-8	Fluid cleanliness	NAS 1638, class 8 or ISO 17/14
Specifications:																																			
Hysteresis	5% typical, 8% maximum																																		
Linearity	8%																																		
Response	P6,7,8      0.9 seconds, zero to full stroke or back P11,14      1.5 seconds, zero to full stroke or back P24, 30      1.8 seconds, zero to full stroke or back																																		
Repeatability	2%																																		
Temperature null shift	<2% per 100°F (38° C)																																		
Servo pressure required	200-1000 psi (14-70 bar), 400 nominal (28 bar)																																		
Coil resistance	41 ohms (24v coil) & 10 ohms (12v coil)																																		
Electrical input*	270 ma minimum, 325 ma nominal, 380 ma maximum (24v coil)																																		
Neutral deadband*	150 ma minimum, 180 ma nominal, 210 ma maximum (24v coil)																																		
Manual override	3/16" Allen wrench, 30 in-lb (3.4Nm) with zero signal																																		
Fluid types	All																																		
Available open-loop drivers	Jupiter 900 card      S20-14078 Dual Driver module      027-22071-0																																		
	Power supply      762-30026-0																																		
	Euro card holder      EX00-S07																																		
Electrical connector	DIN 43650 type AF, 16-01008-8																																		
Fluid cleanliness	NAS 1638, class 8 or ISO 17/14																																		

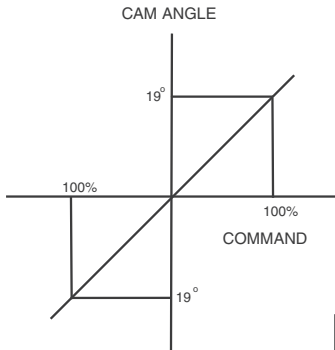
	<p>The 7** control is a high response displacement control that uses a servovalve to direct high flow levels to and from the vane chambers, in order to achieve high stroke rates on the pump. A feedback potentiometer or RVDT (Rotary Variable Differential Transformer) is used to feed back the rocker cam position to the controlling electronics to achieve stable operation.</p> <p>The 7D6 control uses a servovalve and a feedback potentiometer for feedback, the 7D8 uses an RVDT.</p> <p>The 7F6 control uses servovalve and a the feedback potentiometer, but also has a special valve block with a valve in it to shut off the servovalve, so that control may be taken over by a 4A2 control also mounted to the pump as a manual override. The 7F8 is the same, except using an RVDT.</p> <table border="1" data-bbox="527 1459 1421 1858"> <thead> <tr> <th colspan="4">Specifications for 7D,7F:</th> </tr> <tr> <th></th> <th>P6,7,8</th> <th>P11,14</th> <th>P24/30</th> </tr> </thead> <tbody> <tr> <td>Hysteresis</td> <td>&lt;±1%</td> <td>&lt;±1%</td> <td>±1%</td> </tr> <tr> <td>Linearity</td> <td>&lt;±0.5%</td> <td>&lt;±0.5%</td> <td>±0.5%</td> </tr> <tr> <td>Step Response</td> <td>180ms</td> <td>300 Ms</td> <td>360 Ms</td> </tr> <tr> <td>Small Signal Frequency Response</td> <td>10 Hz, 400 psi (28 bar)</td> <td>8.2 Hz., 440 psi (30 bar)</td> <td>6 Hz., 500 psi (35 bar)</td> </tr> <tr> <td></td> <td>17 Hz., 1000psi (70 bar)</td> <td>13 Hz., 1000 psi (70 bar)</td> <td>9 Hz., 1000 psi (70 bar)</td> </tr> <tr> <td>Servo Pressure</td> <td>1000 psi (70 bar) nominal</td> <td></td> <td></td> </tr> <tr> <td>Coil Resistance</td> <td>1000 ohms</td> <td></td> <td></td> </tr> <tr> <td>Electrical Input</td> <td>0-10 ma</td> <td></td> <td></td> </tr> <tr> <td>Feedback Pot Output,</td> <td>±3 VDC</td> <td></td> <td></td> </tr> <tr> <td>    19°, 15 VDC excitation</td> <td></td> <td></td> <td></td> </tr> <tr> <td>Feedback RVDT Output,</td> <td>±2.4 VDC</td> <td></td> <td></td> </tr> <tr> <td>    19°, 15 VDC excitation</td> <td></td> <td></td> <td></td> </tr> <tr> <td>Fluid Types</td> <td>All</td> <td></td> <td></td> </tr> <tr> <td>Fluid Cleanliness</td> <td>NAS 1638, class8 or ISO 17/14</td> <td></td> <td></td> </tr> <tr> <td>Available Drivers</td> <td>Jupiter High IQ S20-11958</td> <td></td> <td></td> </tr> <tr> <td>Electrical Connectors</td> <td>supplied with pump</td> <td></td> <td></td> </tr> </tbody> </table>	Specifications for 7D,7F:					P6,7,8	P11,14	P24/30	Hysteresis	<±1%	<±1%	±1%	Linearity	<±0.5%	<±0.5%	±0.5%	Step Response	180ms	300 Ms	360 Ms	Small Signal Frequency Response	10 Hz, 400 psi (28 bar)	8.2 Hz., 440 psi (30 bar)	6 Hz., 500 psi (35 bar)		17 Hz., 1000psi (70 bar)	13 Hz., 1000 psi (70 bar)	9 Hz., 1000 psi (70 bar)	Servo Pressure	1000 psi (70 bar) nominal			Coil Resistance	1000 ohms			Electrical Input	0-10 ma			Feedback Pot Output,	±3 VDC			19°, 15 VDC excitation				Feedback RVDT Output,	±2.4 VDC			19°, 15 VDC excitation				Fluid Types	All			Fluid Cleanliness	NAS 1638, class8 or ISO 17/14			Available Drivers	Jupiter High IQ S20-11958			Electrical Connectors	supplied with pump		
Specifications for 7D,7F:																																																																									
	P6,7,8	P11,14	P24/30																																																																						
Hysteresis	<±1%	<±1%	±1%																																																																						
Linearity	<±0.5%	<±0.5%	±0.5%																																																																						
Step Response	180ms	300 Ms	360 Ms																																																																						
Small Signal Frequency Response	10 Hz, 400 psi (28 bar)	8.2 Hz., 440 psi (30 bar)	6 Hz., 500 psi (35 bar)																																																																						
	17 Hz., 1000psi (70 bar)	13 Hz., 1000 psi (70 bar)	9 Hz., 1000 psi (70 bar)																																																																						
Servo Pressure	1000 psi (70 bar) nominal																																																																								
Coil Resistance	1000 ohms																																																																								
Electrical Input	0-10 ma																																																																								
Feedback Pot Output,	±3 VDC																																																																								
19°, 15 VDC excitation																																																																									
Feedback RVDT Output,	±2.4 VDC																																																																								
19°, 15 VDC excitation																																																																									
Fluid Types	All																																																																								
Fluid Cleanliness	NAS 1638, class8 or ISO 17/14																																																																								
Available Drivers	Jupiter High IQ S20-11958																																																																								
Electrical Connectors	supplied with pump																																																																								

CODE	DESCRIPTION	HYDRAULIC CIRCUIT
<p>7J6                      7J8                      7K6                      7K8</p>	<p>HIGH IQ                      DF+ CONTROL                      PROPORTIONAL                      VALVE</p>	
<p>--4</p>	<p>TORQUE LIMITER                      OVERRIDE</p>	

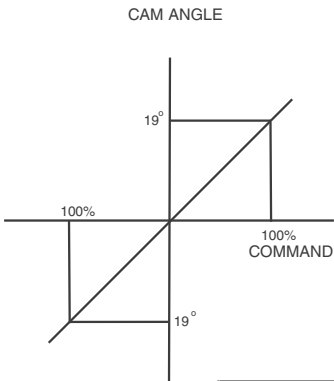
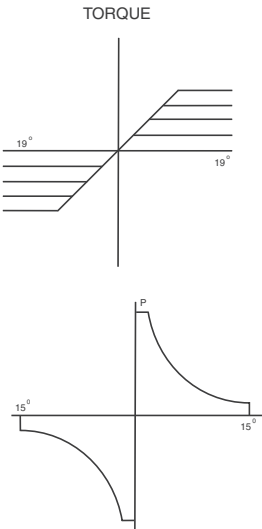
TYPICAL PERFORMANCE	DESCRIPTION OF OPERATION																																																				
	<p>The 700 controls are high response displacement controls that use proportional directional flow control valves to direct high flow levels to and from the vane chambers, in order to achieve high stroke rates on the pump. A feedback potentiometer or RVDT (Rotary Variable Differential Transformer) is used to feed back the rocker cam position to the controlling electronics to achieve stable operation.</p> <p>The 7J6 control uses a proportional directional control valve and a feedback potentiometer for feedback, the 7J8 uses an RVDT.</p> <p>The 7K6 control uses proportional directional control valve and a feedback potentiometer, but also has a special valve block with a valve in it to shut off the servovalve, so that control may be taken over by a 4A2 control also mounted to the pump as a manual override. The 7K8 is the same, except using an RVDT.</p> <table border="1" data-bbox="399 709 1435 1157"> <caption>Specifications for 7J, 7K</caption> <thead> <tr> <th></th> <th>P6,7,8</th> <th>P11,14</th> <th>P24/30</th> </tr> </thead> <tbody> <tr> <td>Hysteresis</td> <td>&lt;±1%</td> <td>&lt;±1%</td> <td>&lt;±1%</td> </tr> <tr> <td>Linearity</td> <td>&lt;±0.9%</td> <td>&lt;±0.9%</td> <td>±0.9%</td> </tr> <tr> <td>Step Response</td> <td>180 ms</td> <td>300 ms</td> <td>300 ms</td> </tr> <tr> <td>Small Signal Frequency Response</td> <td>16 Hz, 400 psi (28 bar) 25 Hz, 1000 psi (70 bar)</td> <td>12 Hz, 440 psi (30 bar) 20 Hz, 1000 psi (70 bar)</td> <td>8 Hz, 500 psi (35 bar) 10 Hz, 1000 psi (70 bar)</td> </tr> <tr> <td>Servo Pressure</td> <td colspan="3">1000 psi (70 bar) nominal</td> </tr> <tr> <td>Coil Resistance</td> <td colspan="3">4 ohms</td> </tr> <tr> <td>Feedback Pot Output</td> <td colspan="3">±3 VDC at 19°, 15 VDC excitation</td> </tr> <tr> <td>Feedback RVDT Output,</td> <td colspan="3">±2.4 VDC at 19°, 15 VDC excitation</td> </tr> <tr> <td>Fluid Types</td> <td colspan="3">All</td> </tr> <tr> <td>Fluid Cleanliness</td> <td colspan="3">NAS 1638, class 8 or ISO 17/14</td> </tr> <tr> <td>Available Drivers</td> <td colspan="3">Digital EC01 cards (see publication LT3-00055-1)</td> </tr> <tr> <td>Electrical Connector</td> <td colspan="3"></td> </tr> </tbody> </table>		P6,7,8	P11,14	P24/30	Hysteresis	<±1%	<±1%	<±1%	Linearity	<±0.9%	<±0.9%	±0.9%	Step Response	180 ms	300 ms	300 ms	Small Signal Frequency Response	16 Hz, 400 psi (28 bar) 25 Hz, 1000 psi (70 bar)	12 Hz, 440 psi (30 bar) 20 Hz, 1000 psi (70 bar)	8 Hz, 500 psi (35 bar) 10 Hz, 1000 psi (70 bar)	Servo Pressure	1000 psi (70 bar) nominal			Coil Resistance	4 ohms			Feedback Pot Output	±3 VDC at 19°, 15 VDC excitation			Feedback RVDT Output,	±2.4 VDC at 19°, 15 VDC excitation			Fluid Types	All			Fluid Cleanliness	NAS 1638, class 8 or ISO 17/14			Available Drivers	Digital EC01 cards (see publication LT3-00055-1)			Electrical Connector			
	P6,7,8	P11,14	P24/30																																																		
Hysteresis	<±1%	<±1%	<±1%																																																		
Linearity	<±0.9%	<±0.9%	±0.9%																																																		
Step Response	180 ms	300 ms	300 ms																																																		
Small Signal Frequency Response	16 Hz, 400 psi (28 bar) 25 Hz, 1000 psi (70 bar)	12 Hz, 440 psi (30 bar) 20 Hz, 1000 psi (70 bar)	8 Hz, 500 psi (35 bar) 10 Hz, 1000 psi (70 bar)																																																		
Servo Pressure	1000 psi (70 bar) nominal																																																				
Coil Resistance	4 ohms																																																				
Feedback Pot Output	±3 VDC at 19°, 15 VDC excitation																																																				
Feedback RVDT Output,	±2.4 VDC at 19°, 15 VDC excitation																																																				
Fluid Types	All																																																				
Fluid Cleanliness	NAS 1638, class 8 or ISO 17/14																																																				
Available Drivers	Digital EC01 cards (see publication LT3-00055-1)																																																				
Electrical Connector																																																					
	<p>The **4 control option can be added to any other control, except the 7**, and will limit the amount of torque accepted by the drive shaft on the pump by reducing displacement if the product of pressure and flow (displacement) exceed a preset value. This will allow the pump to go to full stroke, but not at maximum pressure, and it will allow the pump to go to full pressure, but not at maximum flow. When the condition causing the overload disappears, the pump control reverts to the main displacement control. The pressure compensator override is always in effect, at all times, and its function is not effected by this control in any way.</p> <p>Minimum setting is 25% of maximum input torque.  <math>(5000 \text{ (PSI)} \times \text{MAX Displacement} / 2^{1/2})</math></p>																																																				



Series 6, 7 & 8 Information

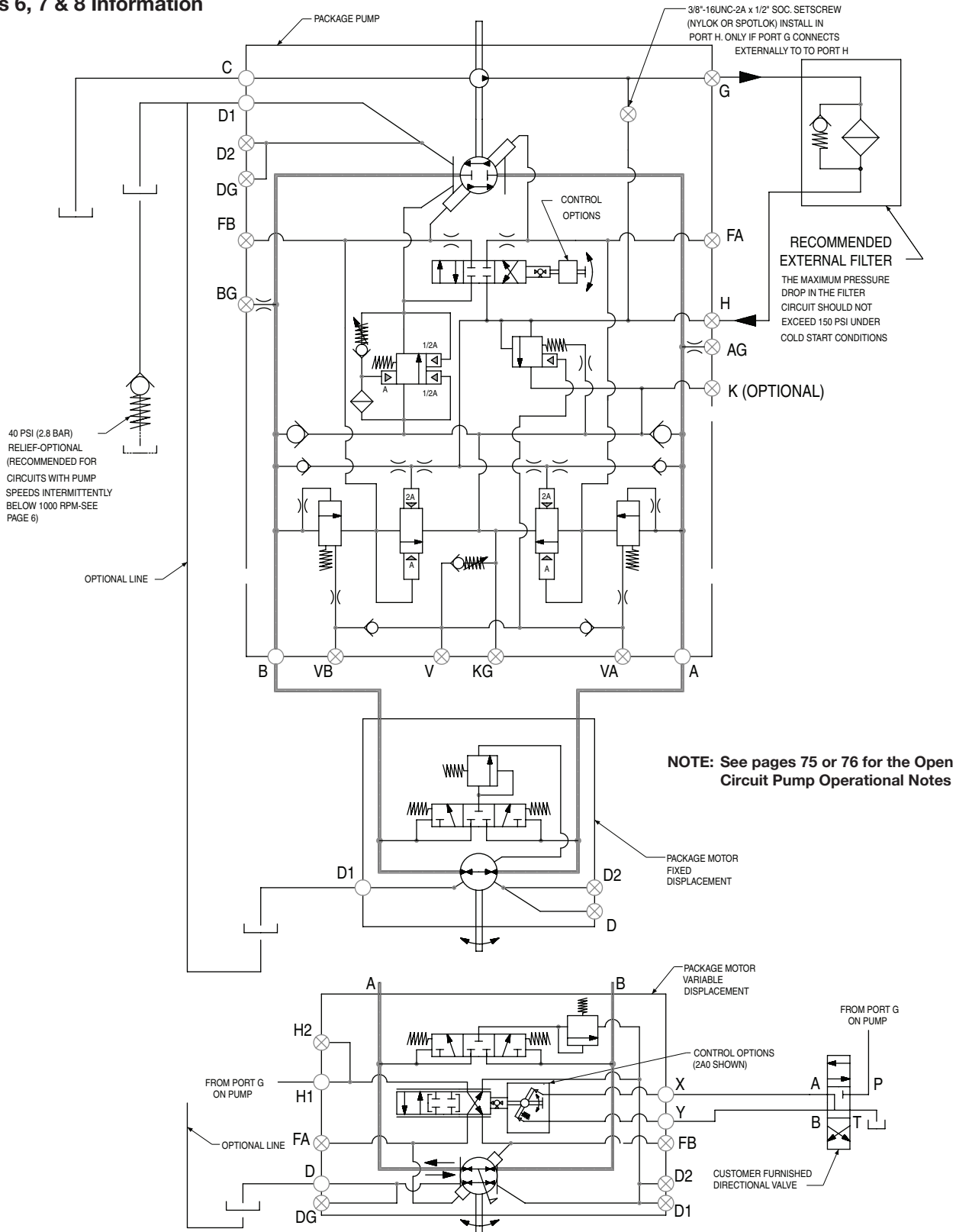

Series 11 & 14 Information

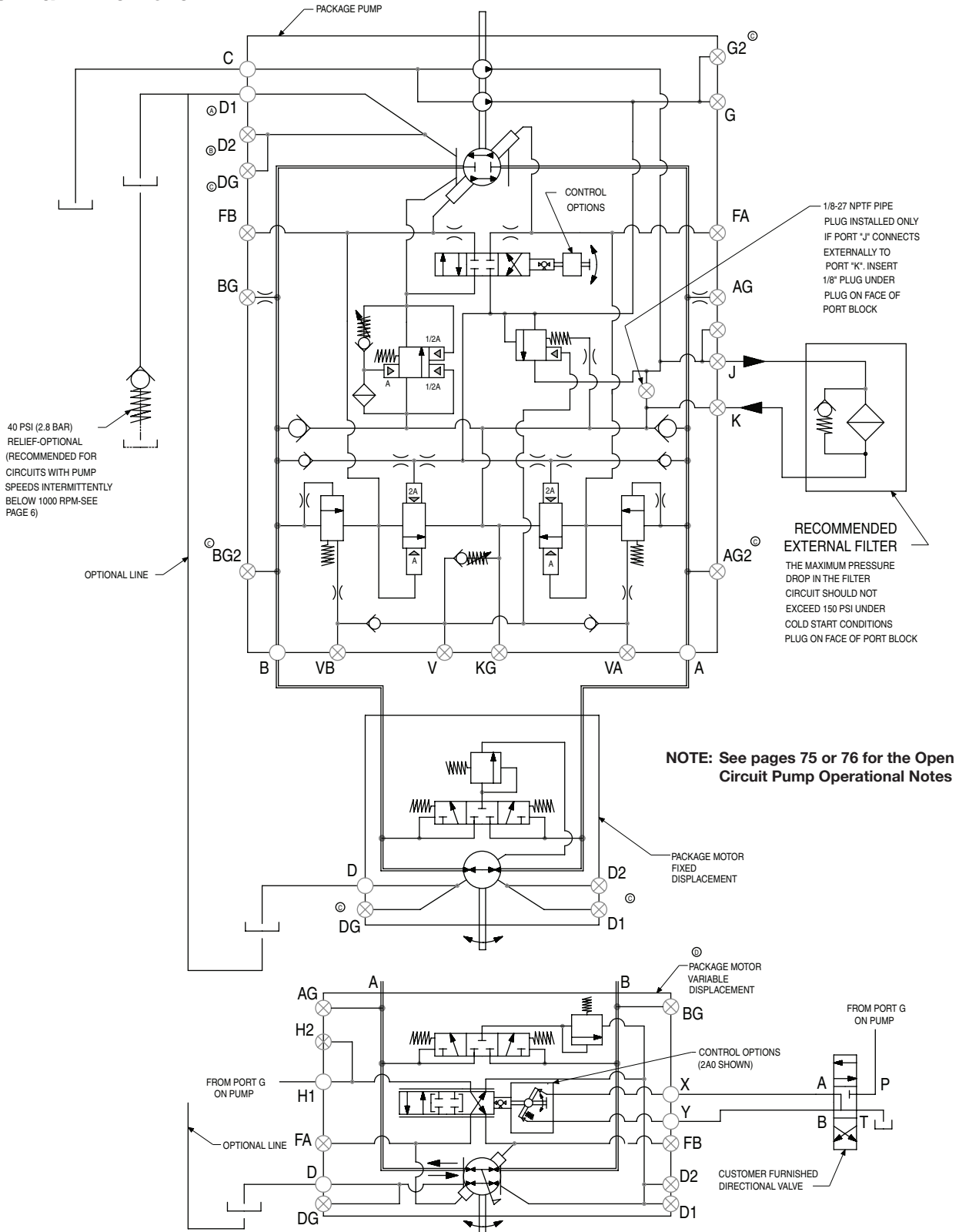



Series 6, 7 & 8 Information

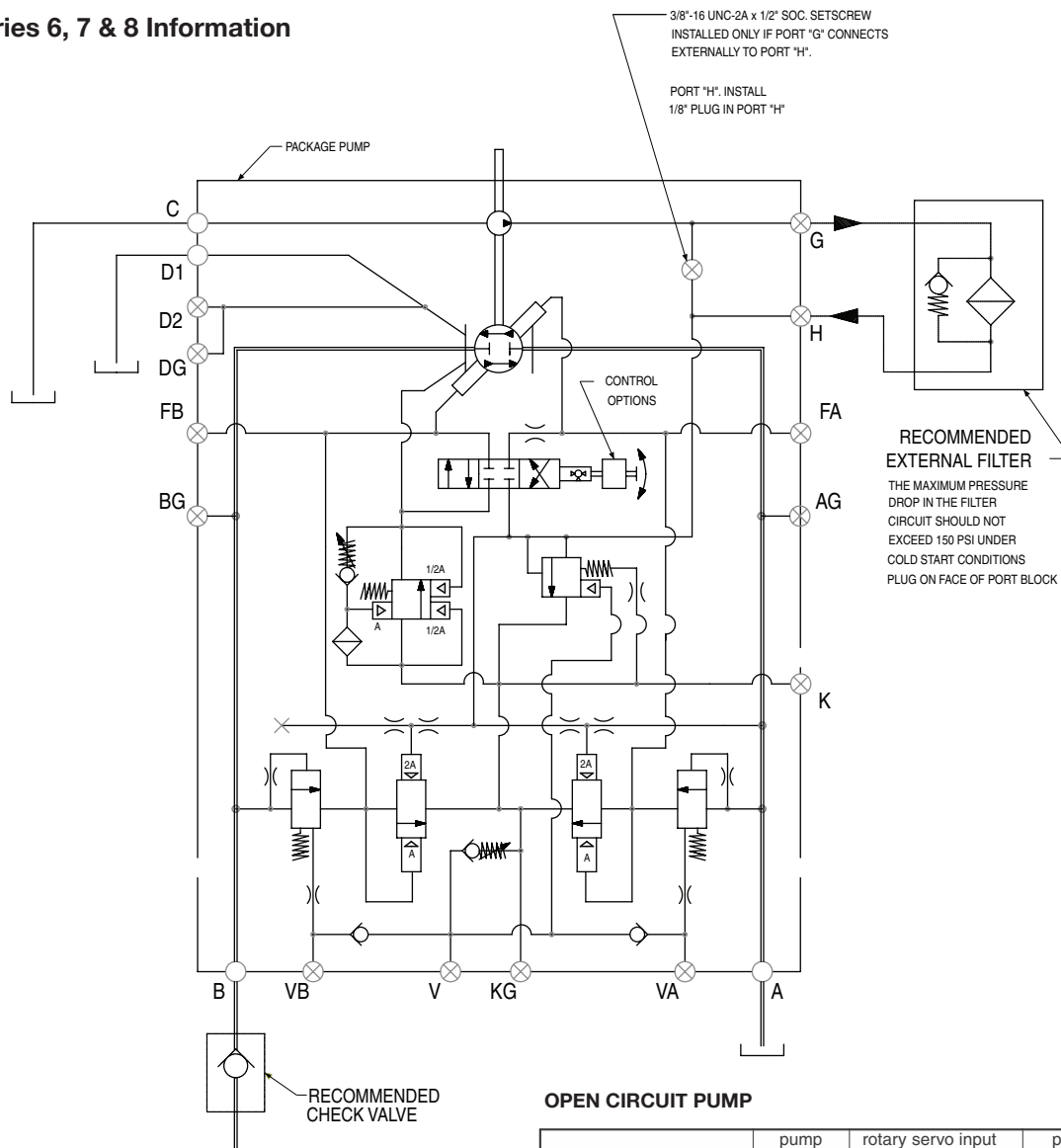

OPEN CIRCUIT PUMP

	pump rotation	rotary servo input shaft rotation	port "A"	port "B"
input command "A" side	R	CW	inlet	outlet
	L	CCW	inlet	outlet
input command "B" side	R	CCW	inlet	outlet
	L	CW	inlet	outlet

NOTES:

1. The auxiliary pump inlet must be connected directly to the reservoir. See page 55 for main pump and auxiliary pump inlet requirements.
2. Case pressure must not exceed inlet pressure by more than 25 psi, 1,7 bar.
3. Maximum allowable inlet (port C) pressure: 200 psi, 13,8 bar.
4. Filters must use bypass valves.
5. Absolute inlet pressure must be increased for the following fluids:
  - a. 25% for water glycols
  - b. 35% for phosphate esters
6. A check valve in the outlet line between the pump and load is highly recommended where hoses, accumulators or other components may decompress when pump is vented by the compensator.

Series 11 & 14 Information

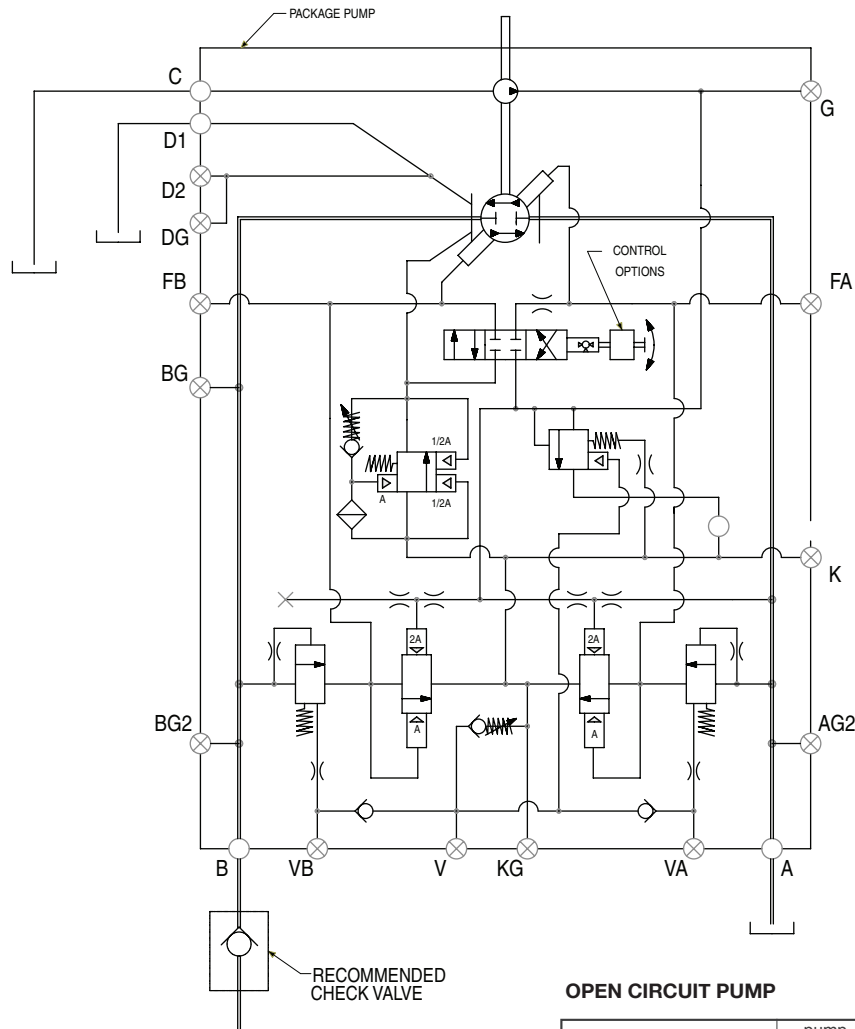

OPEN CIRCUIT PUMP

	pump rotation	rotary servo input shaft rotation	port "A"	port "B"
input command "A" side	R	CW	inlet	outlet
	L	CCW	inlet	outlet
input command "B" side	R	CCW	inlet	outlet
	L	CW	inlet	outlet

NOTES:

1. The auxiliary pump inlet must be connected directly to the reservoir. See page 55 for main pump and auxiliary pump inlet requirements.
2. Case pressure must not exceed inlet pressure by more than 25 psi, 1,7 bar.
3. Maximum allowable inlet (port C) pressure: 200 psi, 13,8 bar.
4. Filters must use bypass valves.
5. Absolute inlet pressure must be increased for the following fluids:
  - a. 25% for water glycols
  - b. 35% for phosphate esters
6. A check valve in the outlet line between the pump and load is highly recommended where hoses, accumulators or other components may decompress when pump is vented by the compensator.



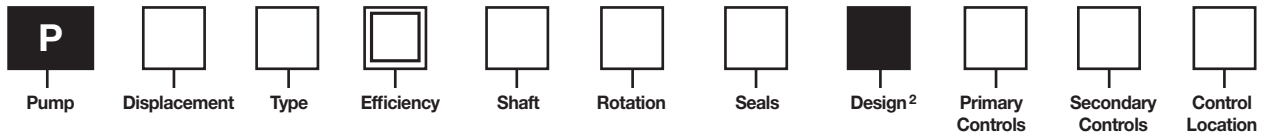

Code	Displacement
6	6.00 in <sup>3</sup> /rev (98 cc/rev)
7	7.25 in <sup>3</sup> /rev (119 cc/rev)
8	8.00 in <sup>3</sup> /rev (131 cc/rev)
11	11.0 in <sup>3</sup> /rev (180 cc/rev)
14	14.0 in <sup>3</sup> /rev (229 cc/rev)
24	24.6 in <sup>3</sup> /rev (403 cc/rev)
30	30.6 in <sup>3</sup> /rev (501 cc/rev)

Code	Rotation
R	Clockwise
L	Counterclockwise

Code	Secondary Controls
Omit	None (Fixed Displacement only)
2	Volume Indicator
4	Torque Limiter & Volume Indicator
6	Cam Position Feedback Potentiometer <sup>1</sup>
7	Cam Position Feedback RVDI (AC) <sup>1</sup>
8	Cam Position Feedback R VDI (DC) <sup>1</sup>

Code	Type
F	Fixed Displacement, Open/Closed Circuit
M	Fixed Displacement with High Torque Thru-Drive, Open/Closed Circuit
P	Variable Displacement, Closed Circuit
X	Variable Displacement with Medium Torque Thru-Drive, Closed Circuit
S	Variable Displacement with Medium Torque Thru-Drive & Shuttle Package, Closed Circuit
R	Variable Displacement with High Torque Thru-Drive, Closed Circuit
L	Variable Displacement with High Torque Thru-Drive & Shuttle Package, Closed Circuit
V	Variable Displacement, Open Circuit (P6, 7, 8, 11 & 14 only)
D	Variable Displacement, Open & Closed Circuit (P6, 7 & 8 only)

Code	Seals
1	Nitrile (Buna-N)
4	EPR <sup>1,3</sup>
5	Fluorocarbon

Code	Control Location
Omit	None (Fixed Displacement only)
A	Primary Control on Port A Side
B	Primary Control on Port B Side

Code	Efficiency
H	High Efficiency (P24 only)
Omit	Standard Efficiency

Code	Primary Controls
Omit	None (Fixed Displacement only)
10	Screw Adjustment (Spring Offset to Maximum Displacement)
2A	Cylinder Control w/Adjustable Maximum Volume Stops
2H	Cylinder Control – 3-Position (Spring Control with Zero Adjustment)
2M	Cylinder Control – 2-Position Electrohydraulic w/Adjustable Maximum Volume Stop (Spring Offset to Minimum Displacement) <sup>1</sup>
2N	Cylinder Control – 3-Position (Spring Centered) Electrohydraulic <sup>1</sup>
40	Rotary Servo – Spring Centered
4A	Rotary Servo – Spring Centered w/Adjustable Maximum Volume Stops
4B	Rotary Servo – Spring Centered w/Automatic Brake Control
4C	Rotary Servo – Spring centered w/Adjustable Maximum Volume Stops & Automatic Brake Control
5A	Electrohydraulic Stroker w/Adjustable Maximum Volume Stops <sup>1</sup>
5C	Electrohydraulic Stroker w/Adjustable Maximum Volume Stops & Automatic Brake Control <sup>1</sup>
7D	High IQ with 10 GPM Servo Valve & Volume Indicator <sup>1</sup>
7F	High IQ with 10 GPM Servo Valve & 4A (Rotary Servo) Control <sup>1</sup>
7J	High IQ with DF+ Valve & Volume Indicator <sup>1</sup>
7K	High IQ with DF+ Valve & 4A (Rotary Servo) Control <sup>1</sup>
8A	Hydraulic Stroker w/Adjustable Maximum Volume Stops
8C	Hydraulic Stroker w/Adjustable Maximum Volume Stops & Automatic Brake Control
9A	Electrohydraulic Stroker w/Adjustable Maximum Volume Stops <sup>1</sup>
9C	Electrohydraulic Stroker w/Adjustable Maximum Volume Stops & Automatic Brake Control <sup>1</sup>
9D	Electro-hydraulic stroker w/adjustable maximum volume stops

- 1 Not ATEX approved.
- 2 Assigned by manufacturer
- 3 Not available when using "5A" or "5C" primary controls. Pump will be unpainted unless otherwise specified.

= Omit if not required

Code	Shaft
2	Keyed SAE – Mechanical Shaft Seal (Single Lip Seal on P6, 7, 8F/M)
3	Splined SAE – Mechanical Shaft Seal (Single Lip Seal on P6, 7, 8F/M)
4	Keyed SAE-D (Mounting & Shaft) – Mechanical Shaft Seal (P6, 7 & 8 only, Single Lip Seal on Fixed Displacement Pumps)
-5	Splined SAE-D (Mounting & Shaft) – Mechanical Shaft Seal (P6, 7 & 8 only, Single Lip Seal on Fixed Displacement Pumps)
7	Keyed SAE – Double Lip Shaft Seal
8	Splined SAE – Double Lip Shaft Seal
9	Keyed (long) SAE – Double Lip Shaft Seal
10	Keyed (long) SAE – Mechanical Shaft Seal

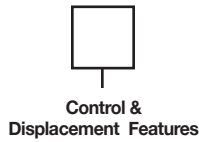

Control	Code	Control & Displacement Features
<b>2M* &amp; 2N*</b>	00	CETOP3, NG6 Valve, 110AC/60Hz with Hirschmann Connector <sup>1</sup>
	01	CETOP3, NG6 Valve, 12VDC with Hirschmann Connector <sup>1</sup>
	02	CETOP3, NG6 Valve, 240VAC/50Hz with Hirschmann Connector <sup>1</sup>
	03	CETOP3, NG6 Valve, 110VAC/60Hz, Wiring Box <sup>1</sup>
	04	CETOP3, NG6 Valve, 12VDC, Wiring Box <sup>1</sup>
	05	CETOP3 (D03, NG6) Interface, No Valve <sup>1</sup>
	06	CETOP3, NG6 Valve, 24VDC with Hirschmann Connector <sup>1</sup>
	07	CETOP3, NG6 Valve, 110VAC/50Hz with Hirschmann Connector <sup>1</sup>
<b>5**</b>	00	With Deadband <sup>1</sup>
	01	Without Deadband <sup>1</sup>
<b>7**</b>	00	Without Manual Override Shutoff <sup>1</sup>
	01	With Manual Override Shutoff <sup>1</sup> (required for F & K primary options)
<b>8**</b>	00	75-350 PSI (5-24 Bar)
	01	75-435 PSI (5-30 Bar)
	02	100-380 PSI (7-26 Bar)
	03	150-400 PSI (10-28 Bar)
	04	75-250 PSI (5-17 Bar)
<b>9**</b>	00	24VDC
	01	12VDC
<b>All Other</b>	00	None <sup>1</sup>
Pump	Code	Reduced Displacement
<b>P**F &amp; P**M</b>	00	Standard Cam (19°)
	10	P6 with 17° Cam – 5.3 in <sup>3</sup> /rev (87cc/rev)
		P7 with 17° Cam – 6.4 in <sup>3</sup> /rev (105 cc/rev)
		P8 with 17° Cam – 7.1 in <sup>3</sup> /rev (116 cc/rev)
		P11 with 17° Cam – 9.7 in <sup>3</sup> /rev (160 cc/rev)
		P14 with 17° Cam – 12.5 in <sup>3</sup> /rev (205 cc/rev)
20	P24 with 17° Cam – 22.0 in <sup>3</sup> /rev (360 cc/rev)	
	P30 with 17° Cam – 27.2 in <sup>3</sup> /rev (446 cc/rev)	
	P6 with 15° Cam – 4.6 in <sup>3</sup> /rev (76 cc/rev)	
	P7 with 15° Cam – 5.6 in <sup>3</sup> /rev (92 cc/rev)	
30	P8 with 15° Cam – 6.2 in <sup>3</sup> /rev (102 cc/rev)	
	P11 with 15° Cam – 8.5 in <sup>3</sup> /rev (140 cc/rev)	
	P14 with 15° Cam – 10.9 in <sup>3</sup> /rev (179 cc/rev)	
	P6 with 13° Cam – 4.0 in <sup>3</sup> /rev (66 cc/rev)	
P7 with 13° Cam – 4.8 in <sup>3</sup> /rev (79 cc/rev)		
	P8 with 13° Cam – 5.3 in <sup>3</sup> /rev (88 cc/rev)	

= Omit if not required

Code	Internal Pump
0	1.07 in <sup>3</sup> /rev (17.5 cc/rev) – P6, 7, 8P/S/X/N/D & P11, 14V only 2.14 in <sup>3</sup> /rev (35 cc/rev) – P11, 14P/S/X only 2.81 in <sup>3</sup> /rev (46 cc/rev) – P24, 30P/S/X only (standard)
1	1.61 in <sup>3</sup> /rev (26.4 cc/rev) – P24, 30P/S/X only (auxiliary external replenishing flow required)
2	1.05 in <sup>3</sup> /rev (17.2 cc/rev) – P24, 30P/S/X only (auxiliary external replenishing flow required)
3	3.56 in <sup>3</sup> /rev (58.3 cc/rev) – P24, 30P/S/X only
4	4.84 in <sup>3</sup> /rev (79.3 cc/rev) – P24, 30P/S/X only
5	5.42 in <sup>3</sup> /rev (88.8 cc/rev) – P24, 30P/S/X only
6	6.10 in <sup>3</sup> /rev (100.0 cc/rev) – P24, 30P/S/X only
X	No Internal Pump (standard on P*R/L/F/M)

Code	External Drive
Omit	None <sup>1</sup>
M	Blanking plate – for P6, 7, 8, 11, 14S/X only
A	SAE-A (SAE 82-2) – P6, 7, 8, 11, 14S/X/R/L/M only
B	SAE-B (SAE 101-2) – P6, 7, 8, 11, 14, 24, 30/S/X/R/L/M SAE-B (SAE 101-4) – P11, 14, 24, 30R/L/M
C	SAE-C (SAE 127-2) – P6, 7, 8, 11, 14, 24, 30R/L/M & P24, 30S/X SAE-C (SAE 127-4) – P11, 14, 24, 30R/L/M
D	SAE-D (SAE 152-4) – P11, 14, 24, 30R/L/M only
E	SAE-E (SAE 165-4) – P11, 14, 24, 30R/L/M only
F	SAE-F (SAE 177-4) – P24, 30R/L/M only

Code	External Mounting
Omit	No External Drive Required
0	No External Pump Mounted
1	External Pump Mounted (must be separately specified) – Requires Special Modification “-M2” <sup>1</sup>
2	ATEX Externally Mounted Pump

Code	Special Modifications
Omit	None
NP	No Paint <sup>1</sup>
EX	ATEX APPROVED PUMP (May contain additional modifications. Contact tech support.)
M2	Other Special Modification (example: bronze caged barrel bearing for low viscosity fluids, tandem pumps, etc.) <sup>1</sup>









Code	Displacement
6	6.00 in <sup>3</sup> /rev (98cc/rev)
7	7.25 in <sup>3</sup> /rev (119 cc/rev)
8	8.00 in <sup>3</sup> /rev (131 cc/rev)
11	11.0 in <sup>3</sup> /rev (180 cc/rev)
14	14.0 in <sup>3</sup> /rev (229 cc/rev)
24	24.6 in <sup>3</sup> /rev (403 cc/rev)
30	30.6 in <sup>3</sup> /rev (501 cc/rev)

Code	Type
F	Fixed Displacement
G	Fixed Displacement with Shuttle Package
M	Fixed Displacement with Thru-Drive
N	Fixed Displacement with Thru-Drive & Shuttle Package
V	Variable Displacement
H	Variable Displacement with Shuttle Package
R	Variable Displacement with Thru-Drive
L	Variable Displacement with Thru-Drive & Shuttle Package

Code	Efficiency
H	High Efficiency (M24 only)
Omit	Standard Efficiency

Code	Shaft
2	Keyed SAE – Mechanical Shaft Seal (Single Lip Seal on M6, 7, 8F/G/M/N)
3	Splined SAE – Mechanical Shaft Seal (Single Lip Seal on M6, 7, 8F/G/M/N)
4	Keyed SAE-D (Mounting & Shaft) – Mechanical Shaft Seal (M6, 7 & 8 only, Single Lip Seal on Fixed Displacement Motors)
5	Splined SAE-D (Mounting & Shaft) – Mechanical Shaft Seal (P6, 7 & 8 only, Single Lip Seal on Fixed Displacement Motors)
7	Keyed SAE – Double Lip Shaft Seal
8	Splined SAE – Double Lip Shaft Seal
9	Keyed (long) SAE – Double Lip Shaft Seal
10	Keyed (long) SAE – Mechanical Shaft Seal

Code	Seals
1	Nitrile (Buna-N)
4	EPR <sup>3</sup>
5	Fluorocarbon

Code	Primary Controls
Omit	None (Fixed Displacement only)
2A	Cylinder Control w/Adjustable Maximum Volume Stops
2M	Cylinder Control – 2-Position Electrohydraulic w/Adjustable Maximum Volume Stop (Spring Offset to Maximum Displacement) <sup>1</sup>
5A	Electrohydraulic Stroker w/ Adjustable Maximum Volume Stops <sup>1</sup>
8A	Hydraulic Stroker w/Adjustable Maximum Volume Stops
9A	Electrohydraulic Stroker w/ Adjustable Maximum Volume Stops <sup>1</sup>

Code	Secondary Controls
Omit	None (Fixed Displacement only)
0	Volume Indicator
3	Reverse Compensator (spring offset to maximum displacement) + Volume Indicator
5	Reverse Compensator (spring offset to minimum displacement) + Volume Indicator
6	Cam Position Feedback Potentiometer <sup>1</sup>
7	Cam Position Feedback RVDT (AC) <sup>1</sup>
8	Cam Position Feedback RVDT (DC) <sup>1</sup>
U	Reverse Compensator (3) + Cam Position Feedback Potentiometer (6) <sup>1</sup>
W	Reverse Compensator (3) + Cam Position Feedback RVDT (8) <sup>1</sup>
X	Reverse Compensator (5) + Cam Position Feedback Potentiometer (6) <sup>1</sup>
Z	Reverse Compensator (5) + Cam Position Feedback RVDT (8) <sup>1</sup>

Code	Control Location
Omit	None (Fixed Displacement only)
A	Primary Control on Port A Side
B	Primary Control on Port B Side

1 Not ATEX approved.  
 2 Assigned by manufacturer.  
 3 Not available when using "5A" primary control. Motor will be unpainted unless otherwise specified.

 = Omit if not required



Control &  
Displacement Features



Shuttle Valve  
Features



External  
Drive



External  
Mounting



Special  
Modifications

Control	Code	Control & Displacement Features
2M	0	CETOP3, NG6 Valve, 110AC/60Hz with Hirschmann Connector <sup>1</sup>
	1	CETOP3, NG6 Valve, 12VDC with Hirschmann Connector <sup>1</sup>
	2	CETOP3, NG6 Valve, 240VAC/50Hz with Hirschmann Connector <sup>1</sup>
	3	CETOP3, NG6 Valve, 110VAC/60Hz, Wiring Box <sup>1</sup>
	4	CETOP3, NG6 Valve, 12VDC, Wiring Box <sup>1</sup>
	5	CETOP3 (D03, NG6) Interface, No Valve <sup>1</sup>
	6	CETOP3, NG6 Valve, 24VDC with Hirschmann Connector <sup>1</sup>
5A	0	With Deadband <sup>1</sup>
	1	Without Deadband <sup>1</sup>
8A	0	75-250 PSI (5-17 Bar)
	1	250-450 PSI (17-31 Bar)
9A	0	24VDC <sup>1</sup>
	1	12VDC <sup>1</sup>
All Other	0	None
Motor	Code	Reduced Displacement
M*F M*G M*M M*N	0	Standard Cam (19°)
	1	M6 with 17° Cam – 5.3 in <sup>3</sup> /rev (87cc/rev)
		M7 with 17° Cam – 6.4 in <sup>3</sup> /rev (105 cc/rev)
		M8 with 17° Cam – 7.1 in <sup>3</sup> /rev (116 cc/rev)
		M11 with 17° Cam – 9.7 in <sup>3</sup> /rev (160 cc/rev)
		M14 with 17° Cam – 12.5 in <sup>3</sup> /rev (205 cc/rev)
2	M24 with 17° Cam – 22.0 in <sup>3</sup> /rev (360 cc/rev)	
	M30 with 17° Cam – 27.2 in <sup>3</sup> /rev (446 cc/rev)	
	M6 with 15° Cam – 4.6 in <sup>3</sup> /rev (76 cc/rev)	
	M7 with 15° Cam – 5.6 in <sup>3</sup> /rev (92 cc/rev)	
	M8 with 15° Cam – 6.2 in <sup>3</sup> /rev (102 cc/rev)	
3	M11 with 15° Cam – 8.5 in <sup>3</sup> /rev (140 cc/rev)	
	M14 with 15° Cam – 10.9 in <sup>3</sup> /rev (179 cc/rev)	
	M6 with 13° Cam – 4.0 in <sup>3</sup> /rev (66 cc/rev)	
		M7 with 13° Cam – 4.8 in <sup>3</sup> /rev (79 cc/rev)
		M8 with 13° Cam – 5.3 in <sup>3</sup> /rev (88 cc/rev)

Code	Shuttle Valve Features
Omit	M*F/M/V/R Motors only
0	Without Orifices
2	With Orifices

Code	External Drive
Omit	None (M*F/G/V/H units only)
A	SAE-A (SAE 82-2) – M6, 7, 8, 11, 14M/N/R/L only
B	SAE-B (SAE 101-2) – M6, 7, 8M/N/R/L SAE-B (SAE 101-2 & 101-4) – M11, 14, 24, 30M/N/R/L
C	SAE-C (SAE 127-2) – M6, 7, 8M/N/R/L SAE-C (SAE 127-2 & 127-4) – M11, 14, 24, 30M/N/R/L
D	SAE-D (SAE 152-4) – M11, 14, 24, 30M/N/R/L only
E	SAE-E (SAE 165-4) – M11, 14, 24, 30M/N/R/L only
F	SAE-F (SAE 177-4) – M24, 30M/N/R/L only
M	Blanking Plate-less Coupling

Code	External Mounting
0	No External Motor Mounted
1	External Motor Mounted (must be separately specified) – Requires Special Modification “-M2”
2	ATEX Externally Mounted Motor

Code	Special Modifications
Omit	None
NP	No Paint
M2	Other Special Modification (example: bronze caged barrel bearing for low viscosity fluids, tandem motors, etc.)
EX	ATEX APPROVED (May contain additional modifications. Contact tech support.)

 = Omit if not required

## Notes

### Revisions

#### October 21, 2014

- Cover page: New catalog date to replace October 21, 2014
- Page 4: Update to P8 data
- Page 6: Added SAE “D” option for R & L type units
- Page 9: Revised text to paragraph on “Mounting”
- Page 79: Change 2M control to read Spring Offset to Minimum instead of Maximum
- Added “Revisions” page

#### July 23, 2019

- Page 26: Updated Adaptor port orientation for P24-P30 P Dimensions (Less Controls)
- Updated footer and address to Hydraulic Pump and Power Systems Division









The items described in this document and other documents and descriptions provided by Parker Hannifin Corporation, Hydraulics Group, and its authorized distributors ("Seller") are hereby offered for sale at prices to be established by Seller. This offer and its acceptance by any customer ("Buyer") shall be governed by all of the following Terms and Conditions. Buyer's order for any item described in its document, when communicated to Seller verbally, or in writing, shall constitute acceptance of this offer. All goods or work described will be referred to as "Products".

1. **Terms and Conditions.** Seller's willingness to offer Products, or accept an order for Products, to or from Buyer is expressly conditioned on Buyer's assent to these Terms and Conditions and to the terms and conditions found on-line at [www.parker.com/saleterms/](http://www.parker.com/saleterms/). Seller objects to any contrary or additional term or condition of Buyer's order or any other document issued by Buyer.
2. **Price Adjustments; Payments.** Prices stated on the reverse side or preceding pages of this document are valid for 30 days. After 30 days, Seller may change prices to reflect any increase in its costs resulting from state, federal or local legislation, price increases from its suppliers, or any change in the rate, charge, or classification of any carrier. The prices stated on the reverse or preceding pages of this document do not include any sales, use, or other taxes unless so stated specifically. Unless otherwise specified by Seller, all prices are F.O.B. Seller's facility, and payment is due 30 days from the date of invoice. After 30 days, Buyer shall pay interest on any unpaid invoices at the rate of 1.5% per month or the maximum allowable rate under applicable law.
3. **Delivery Dates; Title and Risk; Shipment.** All delivery dates are approximate and Seller shall not be responsible for any damages resulting from any delay. Regardless of the manner of shipment, title to any products and risk of loss or damage shall pass to Buyer upon tender to the carrier at Seller's facility (i.e., when it's on the truck, it's yours). Unless otherwise stated, Seller may exercise its judgment in choosing the carrier and means of delivery. No deferment of shipment at Buyers' request beyond the respective dates indicated will be made except on terms that will indemnify, defend and hold Seller harmless against all loss and additional expense. Buyer shall be responsible for any additional shipping charges incurred by Seller due to Buyer's changes in shipping, product specifications or in accordance with Section 13, herein.
4. **Warranty.** Seller warrants that the Products sold hereunder shall be free from defects in material or workmanship for a period of eighteen months from the date of delivery to Buyer. The prices charged for Seller's products are based upon the exclusive limited warranty stated above, and upon the following disclaimer: **DISCLAIMER OF WARRANTY: THIS WARRANTY COMPRISES THE SOLE AND ENTIRE WARRANTY PERTAINING TO PRODUCTS PROVIDED HEREUNDER. SELLER DISCLAIMS ALL OTHER WARRANTIES, EXPRESS AND IMPLIED, INCLUDING MERCHANTABILITY AND FITNESS FOR A PARTICULAR PURPOSE.**
5. **Claims; Commencement of Actions.** Buyer shall promptly inspect all Products upon delivery. No claims for shortages will be allowed unless reported to the Seller within 10 days of delivery. No other claims against Seller will be allowed unless asserted in writing within 60 days after delivery or, in the case of an alleged breach of warranty, within 30 days after the date within the warranty period on which the defect is or should have been discovered by Buyer. Any action based upon breach of this agreement or upon any other claim arising out of this sale (other than an action by Seller for any amount due to Seller from Buyer) must be commenced within thirteen months from the date of tender of delivery by Seller or, for a cause of action based upon an alleged breach of warranty, within thirteen months from the date within the warranty period on which the defect is or should have been discovered by Buyer.
6. **LIMITATION OF LIABILITY. UPON NOTIFICATION, SELLER WILL, AT ITS OPTION, REPAIR OR REPLACE A DEFECTIVE PRODUCT, OR REFUND THE PURCHASE PRICE. IN NO EVENT SHALL SELLER BE LIABLE TO BUYER FOR ANY SPECIAL, INDIRECT, INCIDENTAL OR CONSEQUENTIAL DAMAGES ARISING OUT OF, OR AS THE RESULT OF, THE SALE, DELIVERY, NON-DELIVERY, SERVICING, USE OR LOSS OF USE OF THE PRODUCTS OR ANY PART THEREOF, OR FOR ANY CHARGES OR EXPENSES OF ANY NATURE INCURRED WITHOUT SELLER'S WRITTEN CONSENT, EVEN IF SELLER HAS BEEN NEGLIGENT, WHETHER IN CONTRACT, TORT OR OTHER LEGAL THEORY. IN NO EVENT SHALL SELLER'S LIABILITY UNDER ANY CLAIM MADE BY BUYER EXCEED THE PURCHASE PRICE OF THE PRODUCTS.**
7. **Contingencies.** Seller shall not be liable for any default or delay in performance if caused by circumstances beyond the reasonable control of Seller.
8. **User Responsibility.** The user, through its own analysis and testing, is solely responsible for making the final selection of the system and Product and assuring that all performance, endurance, maintenance, safety and warning requirements of the application are met. The user must analyze all aspects of the application and follow applicable industry standards and Product information. If Seller provides Product or system options, the user is responsible for determining that such data and specifications are suitable and sufficient for all applications and reasonably foreseeable uses of the Products or systems.
9. **Loss to Buyer's Property.** Any designs, tools, patterns, materials, drawings, confidential information or equipment furnished by Buyer or any other items which become Buyer's property, may be considered obsolete and may be destroyed by Seller after two consecutive years have elapsed without Buyer placing an order for the items which are manufactured using such property. Seller shall not be responsible for any loss or damage to such property while it is in Seller's possession or control.
10. **Special Tooling.** A tooling charge may be imposed for any special tooling, including without limitation, dies, fixtures, molds and patterns, acquired to manufacture Products. Such special tooling shall be and remain Seller's property notwithstanding payment of any charges by Buyer. In no event will Buyer acquire any interest in apparatus belonging to Seller which is utilized in the manufacture of the Products, even if such apparatus has been specially converted or adapted for such manufacture and notwithstanding any charges paid by Buyer. Unless otherwise agreed, Seller shall have the right to alter, discard or otherwise dispose of any special tooling or other property in its sole discretion at any time.
11. **Buyer's Obligation; Rights of Seller.** To secure payment of all sums due or otherwise, Seller shall retain a security interest in the goods delivered and this agreement shall be deemed a Security Agreement under the Uniform Commercial Code. Buyer authorizes Seller as its attorney to execute and file on Buyer's behalf all documents Seller deems necessary to perfect its security interest. Seller shall have a security interest in, and lien upon, any property of Buyer in Seller's possession as security for the payment of any amounts owed to Seller by Buyer.
12. **Improper Use and Indemnity.** Buyer shall indemnify, defend, and hold Seller harmless from any claim, liability, damages, lawsuits, and costs (including attorney fees), whether for personal injury, property damage, patent, trademark or copyright infringement or any other claim, brought by or incurred by Buyer, Buyer's employees, or any other person, arising out of: (a) improper selection, improper application or other misuse of Products purchased by Buyer from Seller; (b) any act or omission, negligent or otherwise, of Buyer; (c) Seller's use of patterns, plans, drawings, or specifications furnished by Buyer to manufacture Product; or (d) Buyer's failure to comply with these terms and conditions. Seller shall not indemnify Buyer under any circumstance except as otherwise provided.
13. **Cancellations and Changes.** Orders shall not be subject to cancellation or change by Buyer for any reason, except with Seller's written consent and upon terms that will indemnify, defend and hold Seller harmless against all direct, incidental and consequential loss or damage. Seller may change product features, specifications, designs and availability with notice to Buyer.
14. **Limitation on Assignment.** Buyer may not assign its rights or obligations under this agreement without the prior written consent of Seller.
15. **Entire Agreement.** This agreement contains the entire agreement between the Buyer and Seller and constitutes the final, complete and exclusive expression of the terms of the agreement. All prior or contemporaneous written or oral agreements or negotiations with respect to the subject matter are herein merged.
16. **Waiver and Severability.** Failure to enforce any provision of this agreement will not waive that provision nor will any such failure prejudice Seller's right to enforce that provision in the future. Invalidation of any provision of this agreement by legislation or other rule of law shall not invalidate any other provision herein. The remaining provisions of this agreement will remain in full force and effect.
17. **Termination.** This agreement may be terminated by Seller for any reason and at any time by giving Buyer thirty (30) days written notice of termination. In addition, Seller may by written notice immediately terminate this agreement for the following: (a) Buyer commits a breach of any provision of this agreement (b) the appointment of a trustee, receiver or custodian for all or any part of Buyer's property (c) the filing of a petition for relief in bankruptcy of the other Party on its own behalf, or by a third party (d) an assignment for the benefit of creditors, or (e) the dissolution or liquidation of the Buyer.
18. **Governing Law.** This agreement and the sale and delivery of all Products hereunder shall be deemed to have taken place in and shall be governed and construed in accordance with the laws of the State of Ohio, as applicable to contracts executed and wholly performed therein and without regard to conflicts of laws principles. Buyer irrevocably agrees and consents to the exclusive jurisdiction and venue of the courts of Cuyahoga County, Ohio with respect to any dispute, controversy or claim arising out of or relating to this agreement. Disputes between the parties shall not be settled by arbitration unless, after a dispute has arisen, both parties expressly agree in writing to arbitrate the dispute.
19. **Indemnity for Infringement of Intellectual Property Rights.** Seller shall have no liability for infringement of any patents, trademarks, copyrights, trade dress, trade secrets or similar rights except as provided in this Section. Seller will defend and indemnify Buyer against allegations of infringement of U.S. patents, U.S. trademarks, copyrights, trade dress and trade secrets ("Intellectual Property Rights"). Seller will defend at its expense and will pay the cost of any settlement or damages awarded in an action brought against Buyer based on an allegation that a Product sold pursuant to this Agreement infringes the Intellectual Property Rights of a third party. Seller's obligation to defend and indemnify Buyer is contingent on Buyer notifying Seller within ten (10) days after Buyer becomes aware of such allegations of infringement, and Seller having sole control over the defense of any allegations or actions including all negotiations for settlement or compromise. If a Product is subject to a claim that it infringes the Intellectual Property Rights of a third party, Seller may, at its sole expense and option, procure for Buyer the right to continue using the Product, replace or modify the Product so as to make it noninfringing, or offer to accept return of the Product and return the purchase price less a reasonable allowance for depreciation. Notwithstanding the foregoing, Seller shall have no liability for claims of infringement based on information provided by Buyer, or directed to Products delivered hereunder for which the designs are specified in whole or part by Buyer, or infringements resulting from the modification, combination or use in a system of any Product sold hereunder. The foregoing provisions of this Section shall constitute Seller's sole and exclusive liability and Buyer's sole and exclusive remedy for infringement of Intellectual Property Rights.
20. **Taxes.** Unless otherwise indicated, all prices and charges are exclusive of excise, sales, use, property, occupational or like taxes which may be imposed by any taxing authority upon the manufacture, sale or delivery of Products.
21. **Equal Opportunity Clause.** For the performance of government contracts and where dollar value of the Products exceed \$10,000, the equal employment opportunity clauses in Executive Order 11246, VEVRRA, and 41 C.F.R. §§ 60-1.4(a), 60-741.5(a), and 60-250.4, are hereby incorporated.

## North America

### Industrial

#### USA

##### Chicago Region

Naperville, IL  
Tel: (630) 964 0796

##### Great Lakes Region

Fairlawn, OH  
Tel: (330) 670 2680

##### Northeast Region

Lebanon, NJ  
Tel: (908) 236 4121

##### Pacific Region

Buena Park, CA  
Tel: (714) 228 2509

##### Southern Region

Alpharetta, GA  
Tel: (770) 619 9767

#### Canada

Milton, Ontario  
Tel: (905) 693 3000

#### México

Toluca, Edo. de México  
Tel: (52) 72 2275 4200

### Mobile

#### USA

##### Global Mobile

Lincolnshire, IL  
Tel: (847) 821 1500

##### Central Region

Lincolnshire, IL  
Tel: (847) 821 1500

##### Eastern Region

North Canton, OH  
Tel: (330) 284 3355

##### Midwest Region

Hiawatha, IA  
Tel: (319) 393 1221

##### Southern Region

Aledo, TX  
Tel: (817) 441 1794

##### Western Region

Buena Park, CA  
Tel: (714) 228 2509

#### Canada

Milton, Ontario  
Tel: (905) 693 3000

#### México

Apodaca, N.L.  
Tel: (52) 81 8156 6000

### Truck

#### USA

##### Eastern Region

Cleveland, OH  
Tel: (440) 519 1125

##### Western Region

San Ramon, CA  
Tel: (925) 735 9573

#### Canada

Milton, Ontario  
Tel: (905) 693 3000

#### México

Apodaca, N.L.  
Tel: (52) 81 8156 6000

## Europe

#### Austria

Wiener Neustadt  
Tel: (43) 2622 23501 0

#### Belgium

Nivelles  
Tel: (32) 67 280 900

#### Czech Republic and Slovakia

Klecany  
Tel: (420) 284 083 111

#### Denmark

Ballerup  
Tel: (45) 4356 0400

#### Finland

Vantaa  
Tel: (358) 20 753 2500

#### France

Contamine-sur-Arve  
Tel: (33) 4 50 25 80 25

#### Germany

Kaarst  
Tel: (49) 2131 4016 0

#### Greece

Athens  
Tel: (30) 210 933 6450

#### Hungary

Budapest  
Tel: (36) 1 220 4155

#### Ireland

County Dublin, Baldonnell  
Tel: (353) 1 466 6370

#### Italy

Corsico, Milano  
Tel: (39) 02 45 19 21

#### The Netherlands

Oldenzaal  
Tel: (31) 541 585000

#### Norway

Ski  
Tel: (47) 64 91 10 00

#### Poland

Warsaw  
Tel: (48) 22 57 32400

#### Portugal

Leca da Palmeira  
Tel: (351) 22 999 7360

#### Romania

Bucharest  
Tel: (40) 21 252 1382

#### Russia

Moscow  
Tel: (7) 495 580 9145

#### Slovenia

Novo Mesto  
Tel: (386) 7 337 6650

#### Spain

Madrid  
Tel: (34) 91 675 7300

#### Sweden

Spanga  
Tel: (46) 8 597 95000

#### Ukraine

Kiev  
Tel: (380) 44 494 2731

#### United Kingdom

Warwick,  
Tel: (44) 1926 317878

## Asia Pacific

#### Australia

Castle Hill  
Tel: (61) 2 9634 7777

#### China

Beijing  
Tel: (86) 10 6561 0520

#### Shanghai

Tel: (86) 21 5031 2525

#### Hong Kong

Tel: (852) 2428 8008

#### India

Mahape, Navi Mumbai  
Tel: (91) 22 5613 7081

#### Korea

Seoul  
Tel: (82) 2 559 0400

#### Malaysia

Subang Jaya  
Tel: (60) 3 5638 1476

#### New Zealand

Mt. Wellington  
Tel: (64) 9 574 1744

#### Japan

Tokyo  
Tel: (81) 3 6408 3900

#### Singapore

Jurong Town  
Tel: (65) 6 887 6300

#### Taiwan

Taipei  
Tel: (886) 2 2298 8987

#### Thailand

Bangkok  
Tel: (662) 717 8140

## Middle East

#### United Arab Emirates

Abu Dhabi  
Tel: (971) 2 678 8587

## Latin America

#### Pan American Division

Miami, FL  
Tel: (305) 470 8800

#### Argentina

Buenos Aires  
Tel: (54) 33 2744 4129

#### Brazil

Cachoeirinha RS  
Tel: (55) 51 3470 9144

#### Venezuela

Caracas  
Tel: (58) 212 238 5422

## Africa

#### South Africa

Kempton Park  
Tel: (27) 11 961 0700

