

*The Fluid Column
Technology*

High torque Radial Piston Motors MR Type

Fixed displacement (up to 9000 cm³/rev - 550 in³/rev)

aerospace
climate control
electromechanical
filtration
fluid & gas handling
hydraulics
pneumatics
process control
sealing & shielding



ENGINEERING YOUR SUCCESS.

Conversion factors

1 kg	2.20 lb
1 N	0.225 lbf
1 Nm	0.738 lbf ft
1 bar	14.5 psi
1 l	0.264 US gallon
1 cm ³	0.061 cu in
1 mm	0.039 in
1 °C	(5/9)(°F-32)
1 kW	1.34 hp

Conversion factors

1 lb	0.454 kg
1 lbf	4.448 N
1 lbf ft	1.356 Nm
1 psi	0.068948 bar
1 US gallon	3.785 l
1 cu in	16.387 cm ³
1 in	25.4 mm
1 °F	(9/5)(°C) + 32
1 hp	0.7457 kW



WARNING - USER RESPONSIBILITY

FAILURE OR IMPROPER SELECTION OR IMPROPER USE OF THE PRODUCTS DESCRIBED HEREIN OR RELATED ITEMS CAN CAUSE DEATH, PERSONAL INJURY AND PROPERTY DAMAGE.

This document and other information from Parker-Hannifin Corporation, its subsidiaries and authorized distributors provide product or system options for further investigation by users having technical expertise.

The user, through its own analysis and testing, is solely responsible for making the final selection of the system and components and assuring that all performance, endurance, maintenance, safety and warning requirements of the application are met. The user must analyze all aspects of the application, follow applicable industry standards, and follow the information concerning the product in the current product catalog and in any other materials provided from Parker or its subsidiaries or authorized distributors.

To the extent that Parker or its subsidiaries or authorized distributors provide component or system options based upon data or specifications provided by the user, the user is responsible for determining that such data and specifications are suitable and sufficient for all applications and reasonably foreseeable uses of the components or systems.

Offer for Sale

Please contact your Parker representation for a detailed "Offer for Sale".

Parker Calzoni MR hydraulic motors are of the radial piston type. Unique Fluid Column Technology is utilized to achieve superior performances compared to competitive designs. The motors are engineered for high mechanical and volumetric efficiency over a wide range of speed and torque.

Due to their special design, the MR motors deliver their maximum performance when the application requires high torque values. The MR motors combine precise and smooth movements, both at low speed and during acceleration and deceleration transitions.

In addition, the high starting torque (up to 96%) allows the user to select a smaller displacement of the motor, optimizing the size of all the other system's components.

Other typical characteristics of MR motors are:

- high power to weight ratio
- high volumetric and mechanical efficiency
- high resistance to thermal shock
- very low operating noise levels
- suitable for fire-resistant and biologically degradable fluids
- extremely well suited for control engineering applications
- reversible operation (motor and pump)

MR motors are grouped into 11 different frame sizes, corresponding to 41 standard displacements available.

Motors can be customized by selecting different types of shafts, speed sensors, seals, and connection flanges.

Optional accessories include gearboxes and parking brakes.

Furthermore, MR motors can be equipped with optional built-on manifold blocks (cross relief, anti-cavitation, flushing and drain valves) to suit the customer needs.

To ensure high quality production standards, we maintain a Quality Assurance System, certified to standard EN ISO 9001:2008, ISO 14001:2004 and OHSAS 18001:2007.

The product has been approved by ABS for use on ABS classed vessels (PDA certificate No. 11-GE825176-PDA).

ATEX version is available for use in potentially explosive atmospheres (Directive 94/9/EC).

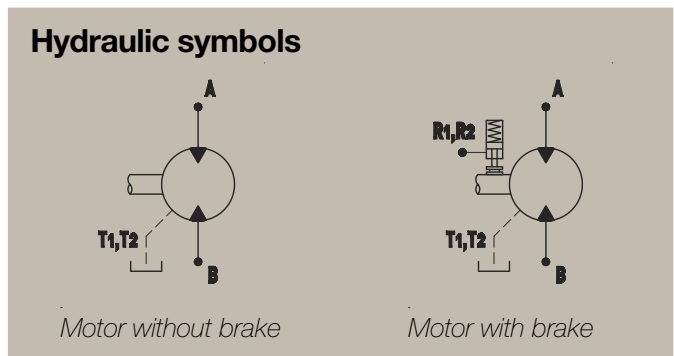

Hydraulic motor	
Construction	Fixed displacement radial piston motors, fluid column type
Mounting type	Flange, shrink disk, wheel (drive coupled with gearbox)
Maximum pressure	Up to 420 bar (6000 psi) ⁽¹⁾
Displacement	Up to 9000 cm ³ /rev (550 in ³ /rev)
Torque	Up to 35000 Nm (25815 lbf·ft)
Temperature range	-30 to +80 °C (-22° to +176°F)
Direction of rotation	Reversible (clockwise / anti-clockwise)
Operation type	Reversible (motor and pump) ⁽²⁾
⁽¹⁾ = Peak value, see operating diagrams for complete motor parameters; ⁽²⁾ = Charge pressure is required during pumping operation (refer to "Operating diagrams" section).	

Examples of installations

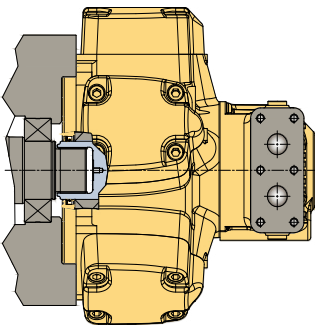

Flange mounted motor

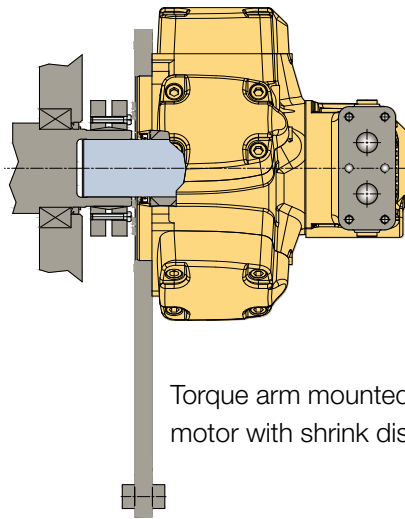

Torque arm mounted motor with shrink disk

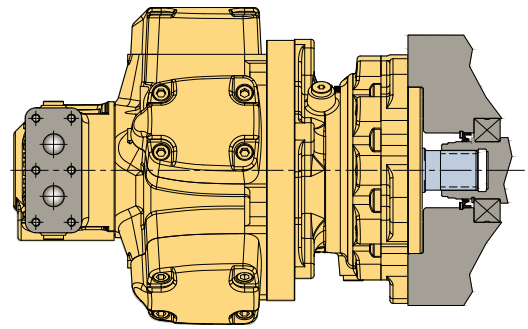

Flange mounted motor with parking brake

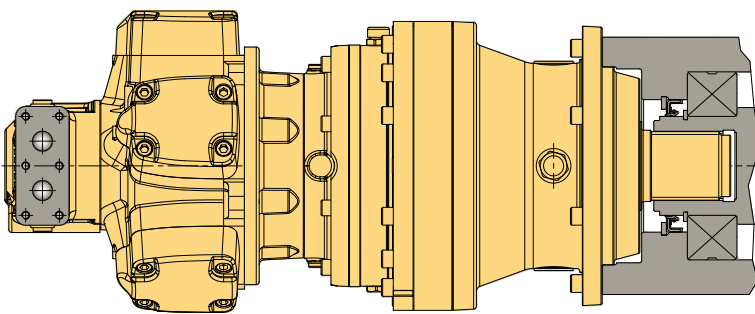

Flange mounted motor with gearbox and parking brake

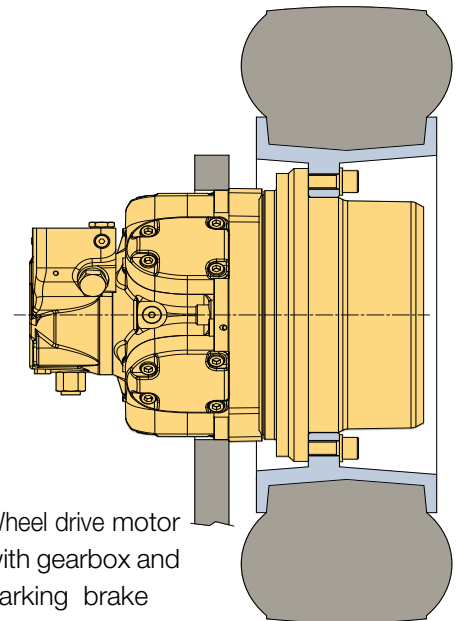

Wheel drive motor with gearbox and parking brake

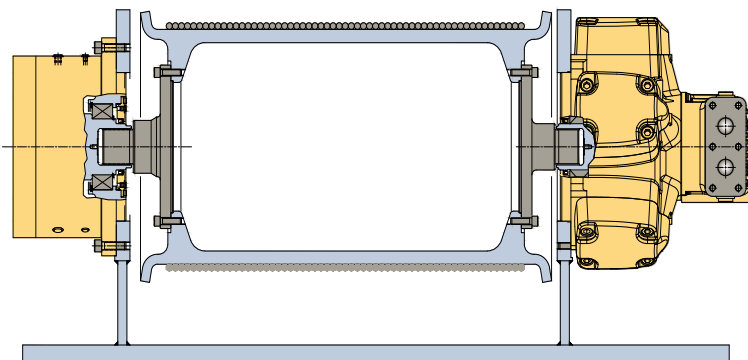

Direct mounted winch drum drive with parking brake

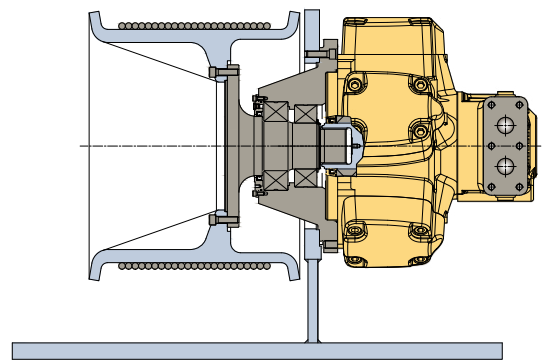

Bracket mounted capstan drive

1

Propulsion: “The fluid column technology”

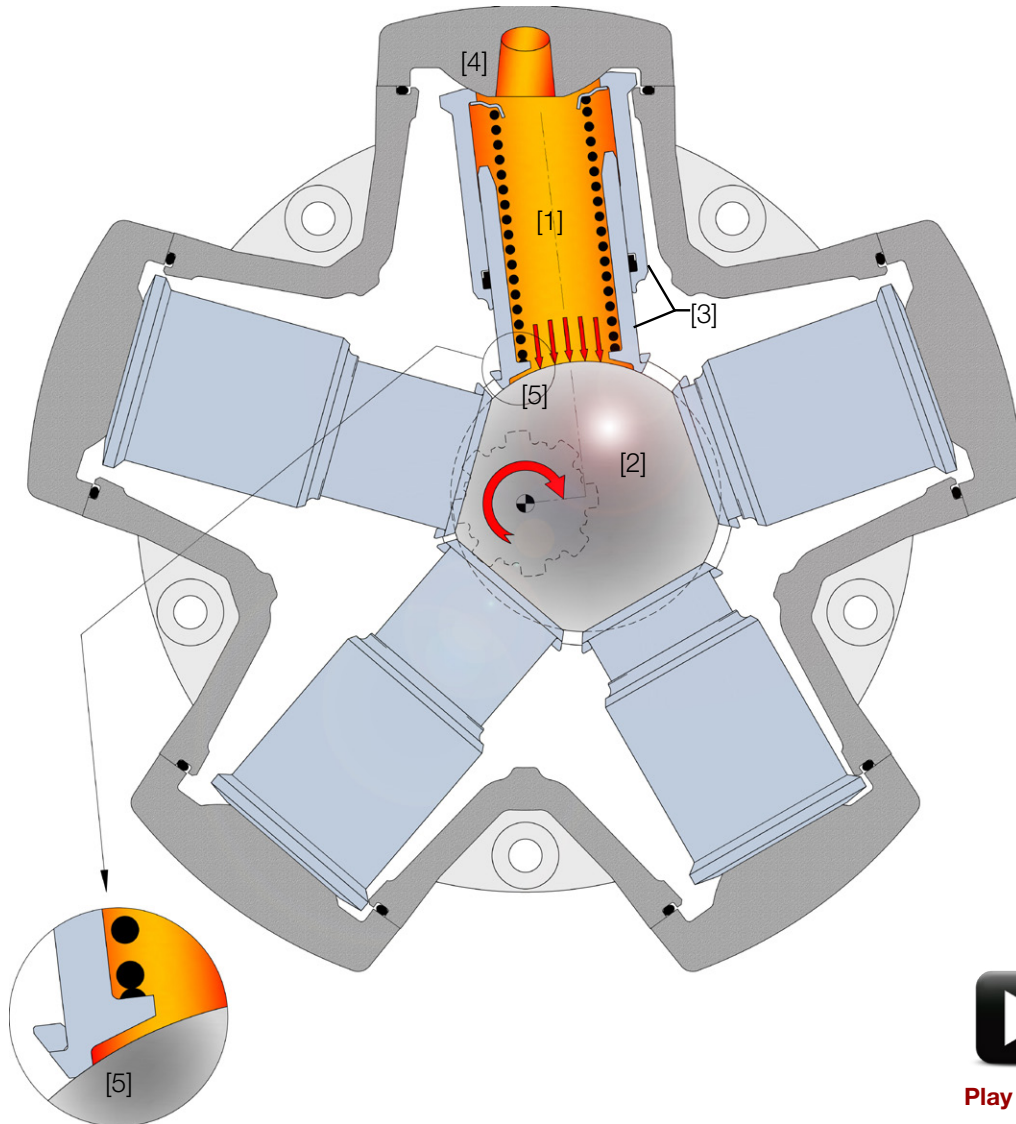

The main concept of this unique and outstanding technology is to convert fluid power (pressure and flow) into mechanical power (torque and speed) by means of pressurized columns of fluid [1] which act directly on a spherical eccentric shaft [2], thereby avoiding the use of conventional connecting rods, pistons, and pins.

Torque is generated by the columns of pressurized fluid [1] that directly push the eccentric cam [2] producing the shaft rotation.

In each propulsion unit, the pressurized fluid is contained within a telescopic cylinder [3] that is sealed by two spherical surfaces, one on the propulsion cover [4] and one on the eccentric shaft [5]. The two spherical surfaces guide the telescopic cylinder so that no side forces are generated during the shaft rotation.

Thanks to the limited friction and wear caused by the “metal to metal” contact, the fluid column propulsion system guarantees high values of volumetric and mechanical efficiency, combined with smooth and precise movements of the motor shaft, even at the lowest speeds.

Timing system: “The balanced forces concept”

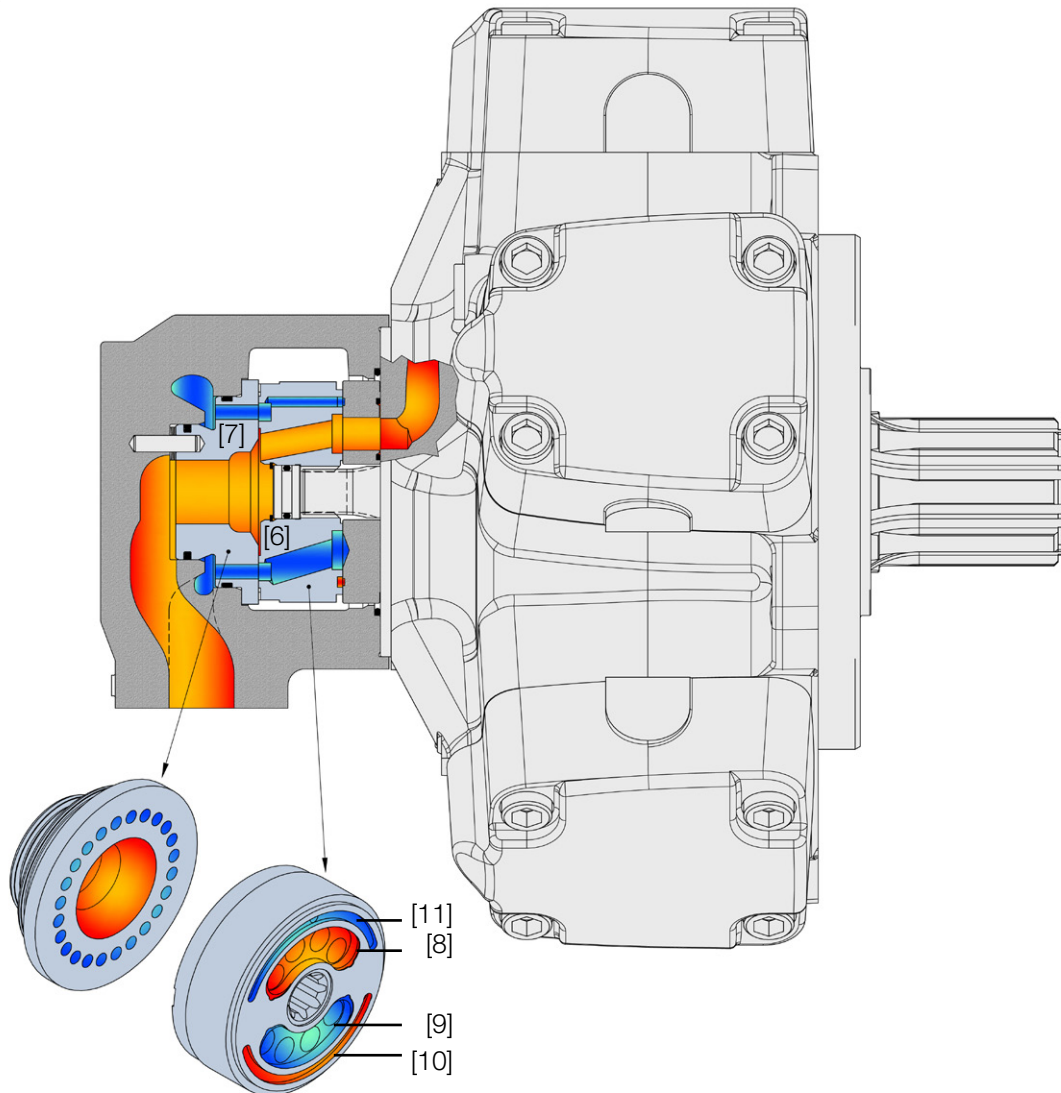

The timing system - consisting of the rotary valve [6] and the reaction ring [7] - supplies the columns of fluid precisely in the correct sequence to generate a smooth motor output torque. While the reaction ring is used to adjust the clearance and to compensate for thermal shocks, the rotary valve rotates at the same speed as the eccentric shaft and connects the reaction ring to the piston chambers by means of two slots [8] and [9]. Two additional balancing slots [10] and [11] cancel the tilting moments (patented), guaranteeing consistent performance for the entire service life.

Product philosophy: “Design for performance and durability”

The human intelligence has always been applied to design mechanisms in which the movements and forces are the result of different components working together providing stresses and strains against each other. Our product philosophy has allowed us to achieve the balancing of each of these movements, making our motors more efficient and resistant to wear and tear over time.

Newton's Third Law

“For every action, there is an equal and opposite reaction”:
inside our motors, we hydraulically transmit and balance forces to generate high torque values combined with low friction and high efficiency.

Calculation fundamentals

Required flow: $Q = \frac{V \cdot n}{1000 \cdot \eta_v}$ (l/min)

Output torque: $M = \frac{V \cdot \Delta p \cdot \eta_m}{62.8} = T_s \cdot \Delta p$ (N·m)

Output power: $P = \frac{Q \cdot \Delta p \cdot \eta_t}{600} = \frac{M \cdot n}{9549}$ (kW)

V = displacement (cm³/rev)
 n = speed (rpm)
 T_s = specific torque (Nm/bar)
 Δp = differential pressure (bar)
 η_v = volumetric efficiency
 η_m = mechanical efficiency
 η_t = overall efficiency

Technical data

Motor type	Displacement	Specific Torque	Speed		Maximum pressure				Max power
			Min	Max	Continuous	Intermittent	Peak	A+B	
-	V	T _s	n _{min}	n _{max}	P _{cont.}	P _{int.}	P _{peak}	P _{A+B}	P _{max.}
-	cm ³ /rev	Nm/bar	rpm	rpm	bar	bar	bar	bar	kW
MR 33 A	32.1	0.51	1.0	1400	250	300	420	400	10
MR 57 A	56.4	0.90	1.0	1300	250	300	420	400	17
MR 73 B	72.6	1.20	1.0	1200	250	300	420	400	20
MR 93 B	92.6	1.50	1.0	1150	250	300	420	400	25
MR 110 B	109.0	1.70	1.0	1100	250	300	420	400	28
MR 125 C	124.7	2.00	1.0	950	250	300	420	400	30
MR 160 C	159.7	2.54	1.0	900	250	300	420	400	34
MR 190 C	191.6	3.05	1.0	850	250	300	420	400	38
MR 200 D	199.2	3.20	1.0	800	250	300	420	400	40
MR 250 D	250.9	4.00	1.0	800	250	300	420	400	50
MR 300 D	304.1	4.80	1.0	750	250	300	420	400	53
MRE 330 D	332.4	5.30	1.0	750	230	280	400	400	49
MRA 400 D	390.5	6.21	1.0	640	210	260	380	400	45
MR 350 E	349.5	5.57	1.0	640	250	300	420	400	62
MR 400 E	400.6	6.38	1.0	620	250	300	420	400	70
MR 450 E	451.6	7.20	1.0	600	250	300	420	400	75
MRE 500 E	497.9	7.93	1.0	600	230	280	400	400	70
MR 600 F	607.9	9.70	1.0	520	250	300	420	400	84
MR 700 F	706.9	11.30	1.0	500	250	300	420	400	97
MRE 800 F	804.2	12.81	1.0	450	230	280	400	400	93

Motor type	Displacement	Specific Torque	Speed		Maximum pressure				Max power
			Min	Max	Continuous	Intermittent	Peak	A+B	
-	V	T _s	n _{min}	n _{max}	p _{cont.}	p _{int.}	p _{peak}	p _{A+B}	P _{max.}
-	cm ³ /rev	Nm/bar	rpm	rpm	bar	bar	bar	bar	kW
MR 1100 G	1125.8	17.9	0,5	330	250	300	420	400	119
MRE 1400 G	1369.5	21.8	0,5	280	230	280	400	400	102
MRA 1600 G	1536.7	24.5	0,5	260	210	260	380	400	96
MR 1600 H	1598.4	25.4	0,5	260	250	300	420	400	144
MR 1800 H	1809.6	28.8	0,5	250	250	300	420	400	153
MRE 2100 H	2091.2	33.3	0,5	250	230	280	400	400	148
MRA 2400 H	2401.4	38.2	0,5	220	210	260	380	400	130
MR 2400 I	2393.0	38.1	0,5	220	250	300	420	400	183
MR 2800 I	2792.0	44.5	0,5	215	250	300	420	400	194
MRE 3100 I	3103.7	49.4	0,5	215	230	280	400	400	190
MRA 3500 I	3490.4	55.6	0,5	180	210	260	380	400	175
MR 3600 L	3636.8	57.9	0,5	180	250	300	420	400	185
MR 4100 L	4104.4	65.3	0,5	175	250	300	420	400	190
MR 4500 L	4502.7	71.7	0,5	170	250	300	420	400	210
MRE 5400 L	5401.2	86.0	0,5	160	230	280	400	400	210
MRA 6000 L	6005.9	95.6	0,5	140	210	260	380	400	190
MR 6500 M	6460.5	103.6	0,5	130	250	300	420	400	240
MR 7000 M	6967.2	111.4	0,5	130	250	300	420	400	250
MRE 7600 M	7628.1	121.4	0,5	130	230	280	400	400	250
MRE 8200 M	8226.4	130.9	0,5	120	230	280	400	400	250
MRA 9000 M	9040.4	143.9	0,5	110	210	260	380	400	230

3

Definitions and guidelines

- Continuous pressure (p_{cont.}): Maximum pressure during continuous working operations.
- Intermittent pressure (p_{int.}): Maximum pressure during non-continuous operations (intermittent pressure may occur max 10% of duty cycle and not more then 20 consecutive seconds inside each cycle).
- Peak pressure (p_{peak}): Pressure exceeding the maximum operating pressure for a short time at which the motor remains able to function (milliseconds corresponding to the reaction time of the system relief valve).
- Additional pressure (p_{A+B}): Maximum sum of inlet pressure and outlet pressure.

Due to its high volumetric efficiency, the motor case must be flushed (refer to Section 9 for flushing flow guidelines) when the output power exceeds 70% of the maximum admitted value P_{max.}, in order to assure the minimum oil viscosity inside the motor case of 30 cSt. The flushing is necessary also when the requested minimum viscosity condition is not assured.



Calculation fundamentals

Required flow: $Q = \frac{V \cdot n}{231 \cdot \eta_v}$ (gpm)

Output torque: $M = \frac{T_s \cdot \Delta p \cdot \eta_m}{1000}$ (lbf-ft)

Output power: $P = \frac{Q \cdot \Delta p \cdot \eta_t}{1714} = \frac{M \cdot n}{5252}$ (hp)

V = displacement (in³/rev)

n = speed (rpm)

T_s = specific torque (lbf-ft/1000 psi)

Δp = differential pressure (psi)

η_v = volumetric efficiency

η_m = mechanical efficiency

η_t = overall efficiency

Technical data

Motor type	Displacement	Specific Torque	Speed		Maximum pressure				Max power
			Min	Max	Continuous	Intermittent	Peak	A+B	
-	V	T _s	n _{min}	n _{max}	P _{cont.}	P _{int.}	P _{peak}	P _{A+B}	P _{max.}
-	in ³ /rev	$\frac{\text{lbf} \cdot \text{ft}}{1000 \cdot \text{psi}}$	rpm	rpm	psi	psi	psi	psi	hp
MR 33 A	1.96	26	1.0	1400	3626	4351	6092	5802	13
MR 57 A	3.44	46	1.0	1300	3626	4351	6092	5802	23
MR 73 B	4.43	59	1.0	1200	3626	4351	6092	5802	27
MR 93 B	5.65	75	1.0	1150	3626	4351	6092	5802	34
MR 110 B	6.65	88	1.0	1100	3626	4351	6092	5802	38
MR 125 C	7.61	101	1.0	950	3626	4351	6092	5802	40
MR 160 C	9.75	129	1.0	900	3626	4351	6092	5802	46
MR 190 C	11.69	155	1.0	850	3626	4351	6092	5802	51
MR 200 D	12.16	161	1.0	800	3626	4351	6092	5802	54
MR 250 D	15.31	203	1.0	800	3626	4351	6092	5802	67
MR 300 D	18.56	246	1.0	750	3626	4351	6092	5802	71
MRE 330 D	20.28	269	1.0	750	3336	4061	5802	5802	66
MRA 400 D	23.83	316	1.0	640	3046	3771	5511	5802	60
MR 350 E	21.33	283	1.0	640	3626	4351	6092	5802	83
MR 400 E	24.45	324	1.0	620	3626	4351	6092	5802	94
MR 450 E	27.56	365	1.0	600	3626	4351	6092	5802	101
MRE 500 E	30.38	403	1.0	600	3336	4061	5802	5802	94
MR 600 F	37.10	492	1.0	520	3626	4351	6092	5802	113
MR 700 F	43.14	572	1.0	500	3626	4351	6092	5802	130
MRE 800 F	49.08	651	1.0	450	3336	4061	5802	5802	125

Motor type	Displacement	Specific Torque	Speed		Maximum pressure				Max power
			Min	Max	Continuous	Intermittent	Peak	A+B	
-	V	T_s	n_{min}	n_{max}	$p_{cont.}$	$p_{int.}$	p_{peak}	p_{A+B}	$P_{max.}$
-	in ³ /rev	$\frac{lbf \cdot ft}{1000 \cdot psi}$	rpm	rpm	psi	psi	psi	psi	hp
MR 1100 G	68.70	911	0,5	330	3626	4351	6092	5802	160
MRE 1400 G	83.57	1108	0,5	280	3336	4061	5802	5802	137
MRA 1600 G	93.78	1244	0,5	260	3046	3771	5511	5802	129
MR 1600 H	97.54	1294	0,5	260	3626	4351	6092	5802	193
MR 1800 H	110.43	1465	0,5	250	3626	4351	6092	5802	205
MRE 2100 H	127.61	1692	0,5	250	3336	4061	5802	5802	198
MRA 2400 H	146.54	1943	0,5	220	3046	3771	5511	5802	174
MR 2400 I	146.03	1937	0,5	220	3626	4351	6092	5802	245
MR 2800 I	170.38	2260	0,5	215	3626	4351	6092	5802	260
MRE 3100 I	189.40	2512	0,5	215	3336	4061	5802	5802	255
MRA 3500 I	213.00	2825	0,5	180	3046	3771	5511	5802	235
MR 3600 L	221.93	2943	0,5	180	3626	4351	6092	5802	248
MR 4100 L	250.47	3322	0,5	175	3626	4351	6092	5802	255
MR 4500 L	274.77	3644	0,5	170	3626	4351	6092	5802	282
MRE 5400 L	329.60	4371	0,5	160	3336	4061	5802	5802	282
MRA 6000 L	366.50	4861	0,5	140	3046	3771	5511	5802	255
MR 6500 M	394.24	5229	0,5	130	3626	4351	6092	5802	322
MR 7000 M	425.16	5639	0,5	130	3626	4351	6092	5802	335
MRE 7600 M	465.50	6173	0,5	130	3336	4061	5802	5802	335
MRE 8200 M	502.01	6658	0,5	120	3336	4061	5802	5802	335
MRA 9000 M	551.68	7316	0,5	110	3046	3771	5511	5802	308

4

Definitions and guidelines

- Continuous pressure ($p_{cont.}$): Maximum pressure during continuous working operations.
- Intermittent pressure ($p_{int.}$): Maximum pressure during non-continuous operations (intermittent pressure may occur max 10% of duty cycle and not more then 20 consecutive seconds inside each cycle).
- Peak pressure (p_{peak}): Pressure exceeding the maximum operating pressure for a short time at which the motor remains able to function (milliseconds corresponding to the reaction time of the system relief valve).
- Additional pressure (p_{A+B}): Maximum sum of inlet pressure and outlet pressure.

Due to its high volumetric efficiency, the motor case must be flushed (refer to Section 9 for flushing flow guidelines) when the output power exceeds 70% of the maximum admitted value $P_{max.}$, in order to assure the minimum oil viscosity inside the motor case of 30 cSt. The flushing is necessary also when the requested minimum viscosity condition is not assured.



Ordering codes

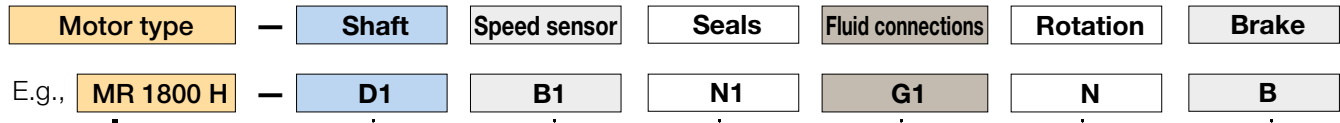

Complete motors list at page 8 ([Metric units](#)) and page 10 ([US and imperial units](#)).

Code	Description	
N1	Splined male shaft, according to standard DIN 5463	16-17
D1	Splined male shaft, according to standard DIN 5480	16-17
F1	Splined female shaft, according to standard DIN 5480	18-19
P1	Male shaft with key	18-19
B1	Splined male shaft, according to standard BS 3550	16-17
C1	Shrink disk coupling	20

Code	Description
N1	NBR mineral oil, 5 bar shaft seal
F1	NBR mineral oil, 15 bar shaft seal
U1	No shaft seal (for brake coupling)
V1	FPM (Viton®)

Code	Description	
-	None	-
B	Parking brake	30

Code	Description
N	Clockwise
S	Anti clockwise

Code	Description	
N1	None	-
C1	Connection for mechanical tachometer	21
Q1	Connection for encoder	21
T1	Connection for Tacho-generator	21
M1	Monodirectional incremental encoder	22
B1	Bidirectional incremental encoder	22

Code	Description	
N1	Six-bolt connection (for manifold blocks)	23
G3	High pressure SAE metric connection (6000 psi)	24-25
L3	High pressure SAE UNC connection (6000 psi)	24-25
S1	Standard pressure SAE metric adaptor	26-27
T1	Standard pressure SAE UNC adaptor	26-27
G1	High pressure SAE metric flange (6000 psi)	28
L1	High pressure SAE UNC flange (6000 psi)	28
C1	BSP threads flange (according to ISO 228/1)	29

Rotation direction for standard motors (code "N") is clockwise when the inlet flow comes from the motor port "A" and motor is viewed from shaft end (anti-clockwise with inlet flow from the motor port "B").

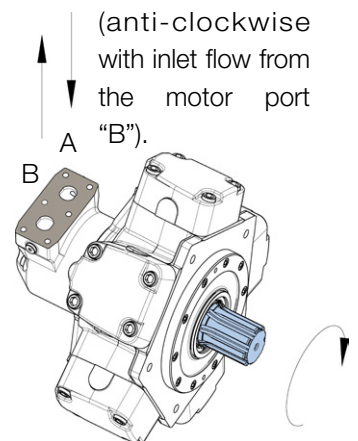

Speed sensors

Fluid connections

Output shafts

from page 21
to page 23

from page 24
to page 29

from page 16
to page 20

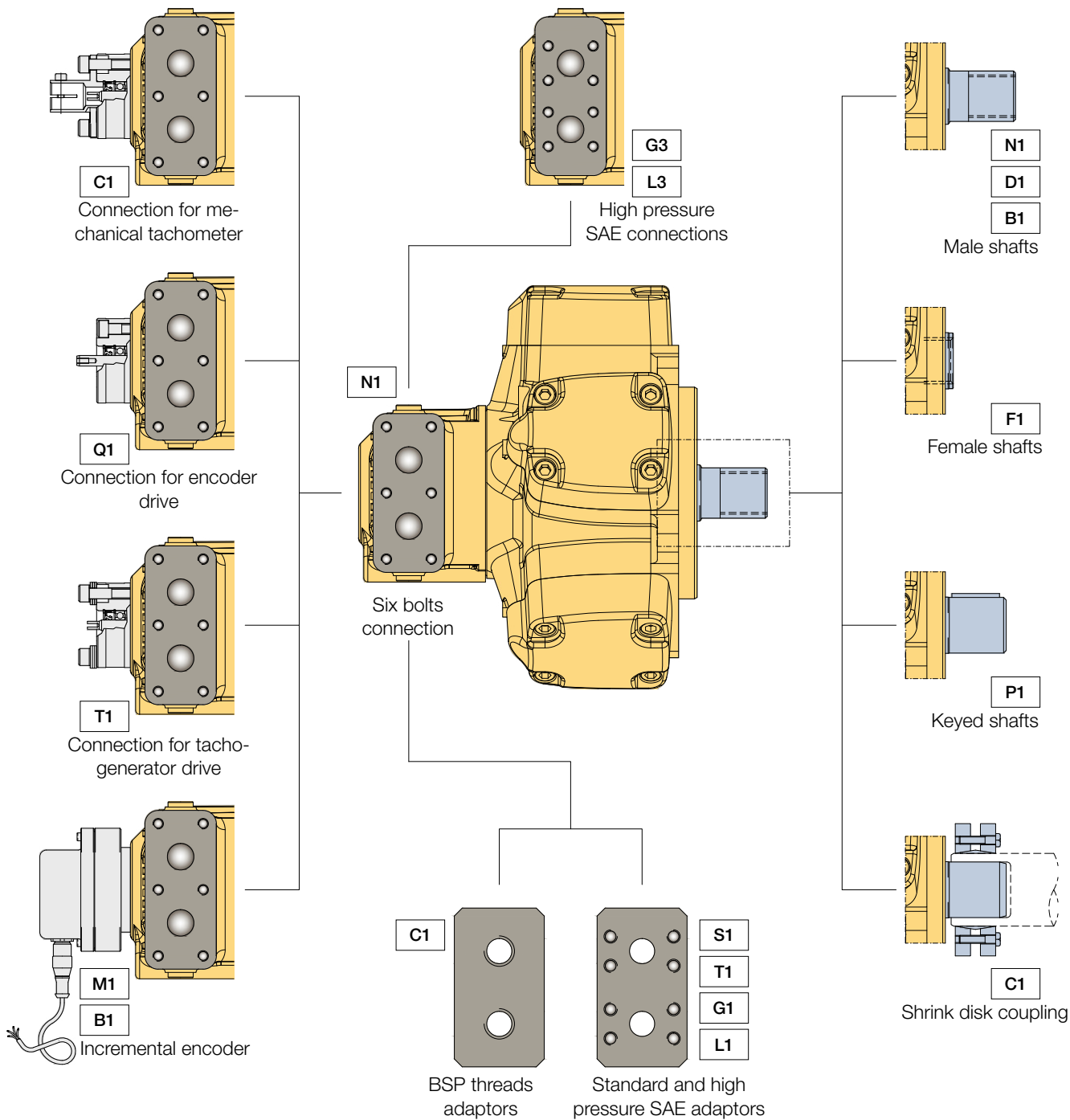

5

Main dimensions

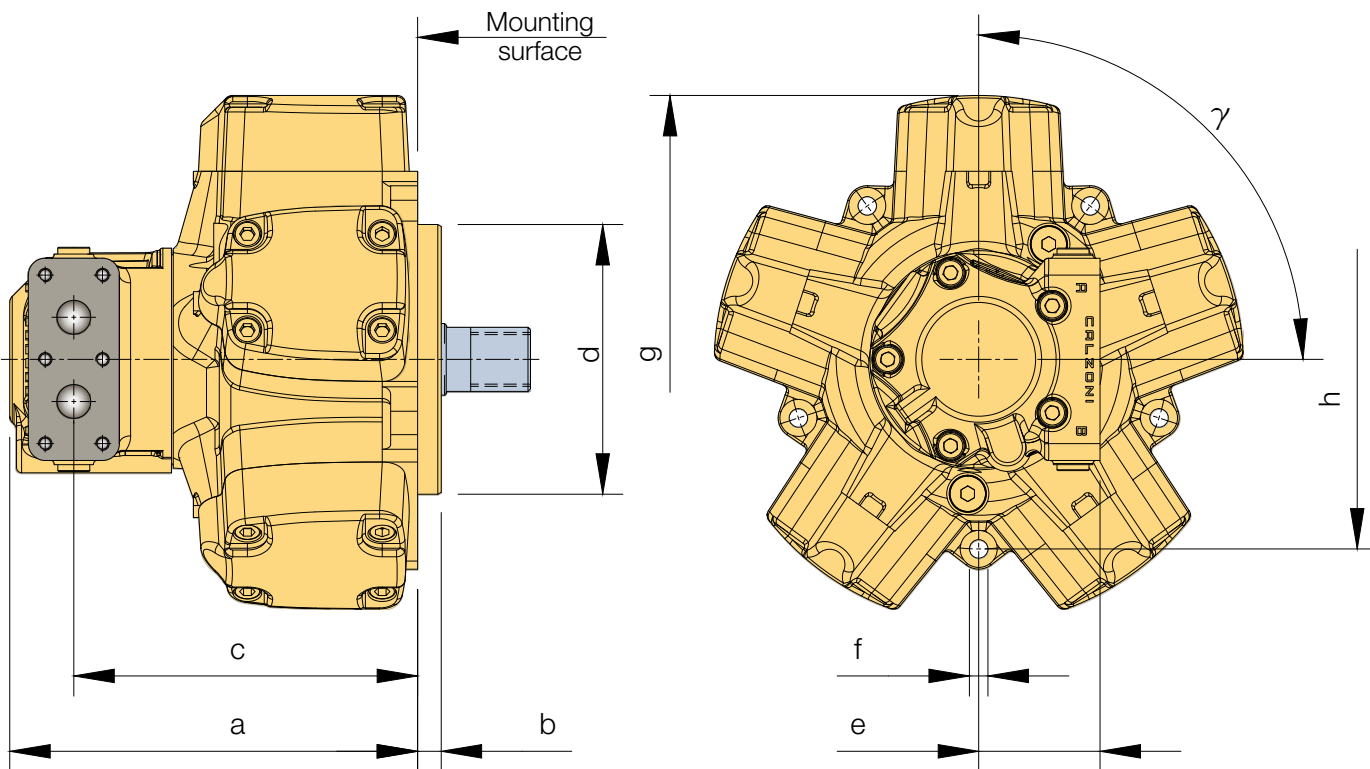

Motor type	a	b	c	d	e	f	g	h	γ	Mass									
MR 33 A	196	14	148	125	70	9	235.4	160	108°	30 kg									
MR 57 A	[7.72]	[0.55]	[5.83]	[4.92]	[2.76]	[0.35]	[9.27]	[6.30]		66 lb									
MR 73 B	228.5	17	190.5	145	72	11	250	204	90°	38 kg									
MR 93 B											[9.00]	[0.67]	[7.50]	[5.71]	[2.83]	[0.43]	[9.84]	[8.03]	84 lb
MR 110 B																			
MR 125 C	242	14	204	160	72	11	313.6	225	90°	46 kg									
MR 160 C											[9.53]	[0.55]	[8.03]	[6.30]	[2.83]	[0.43]	[12.35]	[8.86]	101 lb
MR 190 C																			
MR 200 D	242	15	204	175	72	11	328	232	90*	50 kg									
MR 250 D																			
MR 300 D											[9.53]	[0.59]	[8.03]	[6.89]	[2.83]	[0.43]	[12.91]	[9.13]	110 lb
MRE 330 D																			
MRA 400 D														344 [13.54]					

Measures in millimeters [inches in brackets]

Motor type	a	b	c	d	e	f	g	h	γ	Mass
MR 350 E	270.5 [10.65]	15 [0.59]	235 [9.25]	190 [7.48]	84 [3.31]	13 [0.51]	368 [14.49]	266 [10.47]	90°	77 kg 170 lb
MR 400 E										
MR 450 E										
MRE 500 E										
MR 500 F	290.5 [11.44]	15 [0.59]	255 [10.04]	220 [8.66]	84 [3.31]	13 [0.51]	405 [15.94]	290 [11.42]	90°	97 kg 214 lb
MR 600 F										
MR 700 F										
MRE 800 F										
MR 1100 G	341 [13.43]	20 [0.79]	293 [11.54]	250 [9.84]	105 [4.13]	15 [0.59]	470	330 [12.99]	104°	140 kg 309 lb
MRE 1400 G							[18.50]			
MRA 1600 G							474 [18.66]			
MR 1600 H	374 [14.72]	21 [0.83]	326 [12.83]	290 [11.42]	105 [4.13]	17 [0.67]	558 [21.97]	380 [14.96]	90°	209 kg 460 lb
MR 1800 H										
MRE 2100 H										
MRA 2400 H										
MR 2400 I	466 [18.35]	24 [0.94]	392 [15.43]	335 [13.19]	123 [4.84]	19 [0.75]	642 [25.28]	440 [17.30]	90°	325 kg 716 lb
MR 2800 I										
MRE 3100 I										
MRA 3500 I										
MR 3600 L	489.5 [19.27]	34 [1.34]	418.5 [16.48]	400 [15.75]	123 [4.84]	23 [0.91]	766 [30.16]	540 [21.26]	108°	508 kg 1120 lb
MR 4100 L										
MR 4500 L										
MRE 5400 L										
MR 6500 M	566 [22.28]	37 [1.46]	495 [19.49]	450 [17.72]	123 [4.84]	25 [0.98]	864 [34.02]	600 [23.62]	108°	800 kg 1764 lb
MR 7000 M										
MRE 7600 M										
MRE 8200 M										
MRA 9000 M										

Measures in millimeters [inches in brackets]



Male shafts

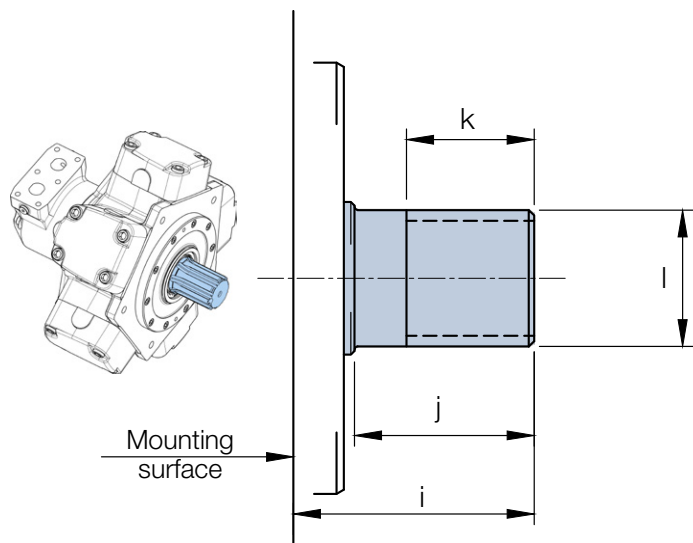

Code	Output shaft
N1	Splined male shaft, according to standard DIN 5463
D1	Splined male shaft, according to standard DIN 5480
B1	Splined male shaft, according to standard BS 3550

Motor type	Option code "N1" (standard UNI 5463)				Option code "D1" (standard DIN 5480)		Option code "B1" (standard BS 3550)				
	i	j	k	l	k	l	k	l			
MR 33 A	57.2	40.2	28	B6x26x32	28	W32x1.5x20-8e	28	12/24-14			
MR 57 A	[2.25]	[1.58]	[1.10]								
MR 73 B	68.5	44.8	31.5	B6x28x34	33.5	W35x2x16-8e	31.5	12/24-16			
MR 93 B									[2.70]	[1.76]	[1.24]
MR 110 B											
MR 125 C	67	50	35.5	B8x32x38	35.5	W38x2x18-8e	35.5	12/24-17			
MR 160 C									[2.64]	[1.97]	[1.40]
MR 190 C											
MR 200 D	81	60	46	B8x42x48	45	W48x2x22-8e	46	12/24-21			
MR 250 D									[3.19]	[2.36]	[1.81]
MR 300 D											
MRE 330 D											
MRA 400 D											
MR 350 E	97	74	56.5	B8x46x54	61	W55x3x17-8e	60	8/16-17			
MR 400 E									[3.82]	[2.91]	[2.22]
MR 450 E											
MRE 500 E											

Measures in millimeters [inches in brackets]

Motor type	i	j	Option code "N1" (standard UNI 5463)		Option code "D1" (standard DIN 5480)		Option code "B1" (standard BS 3550)	
			k	l	k	l	k	l
MR 500 F	101 [3.98]	78 [3.07]	62 [2.44]	B8x52x60	62 [2.44]	W60x3x18-8e	62 [2.44]	8/16-17
MR 600 F								
MR 700 F								
MRE 800 F								
MR 1100 G	117 [4.61]	88 [3.46]	69 [2.72]	B8x62x72	67 [2.64]	W70x3x22-8e	72 [2.83]	6/12-14
MRE 1400 G								
MRA 1600 G								
MR 1600 H	132 [5.20]	100 [3.94]	79 [3.11]	B10x72x82	76 [2.99]	W80x3x25-8e	80 [3.15]	6/12-20
MR 1800 H								
MRE 2100 H								
MRA 2400 H								
MR 2400 I	153 [6.02]	120 [4.72]	99 [3.90]	B10x82x92	76 [2.99]	W90x4x21-8e	100 [3.94]	6/12-20
MR 2800 I								
MRE 3100 I								
MRA 3500 I								
MR 3600 L	210 [8.27]	173 [6.81]	144 [5.67]	B10x102x112	142.5 [5.61]	W110x4x26-8e	144 [5.67]	6/12-20
MR 4100 L								
MR 4500 L								
MRE 5400 L								
MR 6500 M	230 [9.06]	188 [7.40]	150 [5.91]	B10x112x125	153 [6.02]	W120x4x28-8e	153 [6.02]	6/12-26
MR 7000 M								
MRE 7600 M								
MRE 8200 M								
MRA 9000 M								

Measures in millimeters [inches in brackets]

Female and keyed shafts

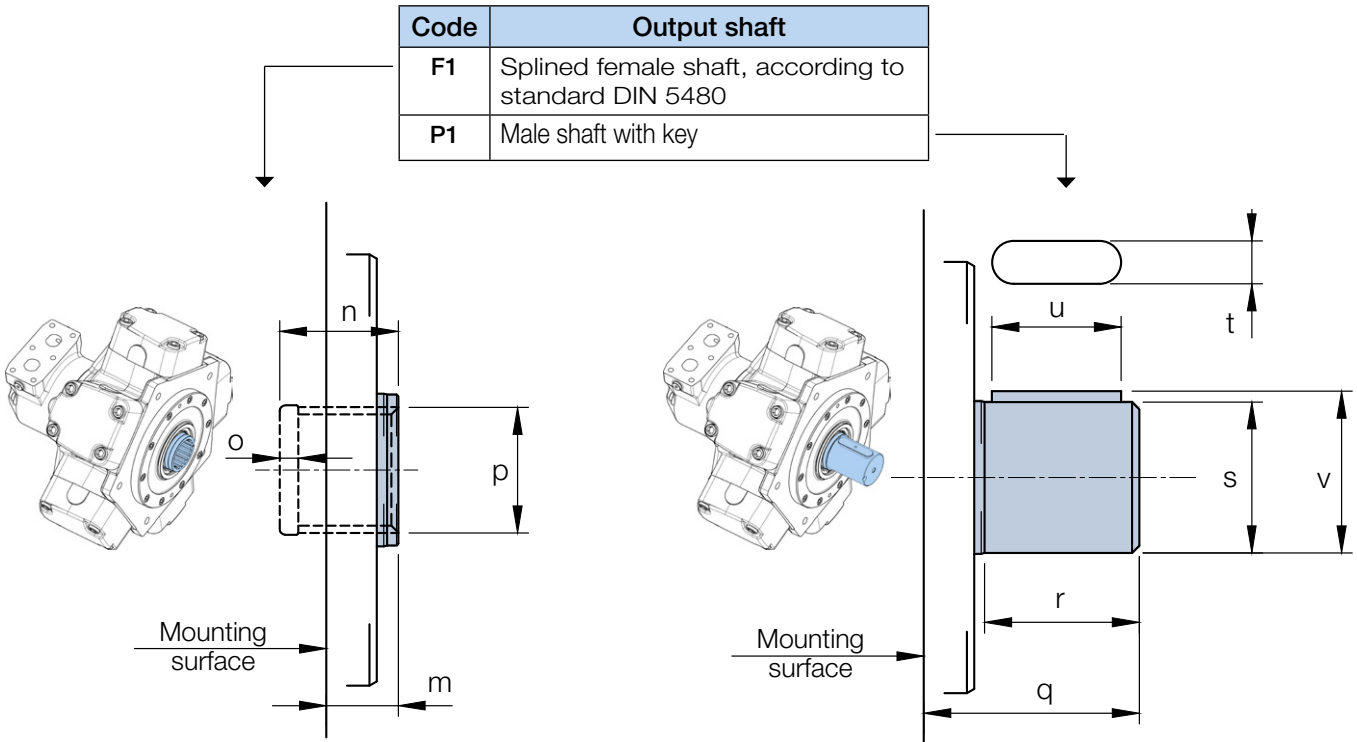

Code	Output shaft
F1	Splined female shaft, according to standard DIN 5480
P1	Male shaft with key

Motor type	Female shafts - Option code "F1" (standard DIN 5480)				Keyed shafts - Option code "P1"														
	m	n	o	p	q	r	s	t	u	v									
MR 33 A	17	26	5	N28x1.25x21-9H	57.2	40.2	30	8	36	33									
MR 57 A	[0.67]	[1.02]	[0.20]		[2.25]	[1.58]	[1.18]	[0.31]	[1.42]	[1.30]									
MR 73 B	17	31.2	5.2	N32x2x14-9H	68.5	44.8	35	10	40	38									
MR 93 B											[0.67]	[1.23]	[0.20]	[2.70]	[1.76]	[1.38]	[0.39]	[1.57]	[1.50]
MR 110 B																			
MR 125 C	14	33	5.2	N35x2x16-9H	67	50	40	12	45	43									
MR 160 C											[0.55]	[1.30]	[0.20]	[2.64]	[1.97]	[1.57]	[0.47]	[1.77]	[1.69]
MR 190 C																			
MR 200 D	27	41	5.2	N40x2x18-9H	81	60	50	14	56	53.5									
MR 250 D											[1.06]	[1.61]	[0.20]	[3.19]	[2.36]	[1.97]	[0.55]	[2.20]	[2.11]
MR 300 D																			
MRE 330 D																			
MRA 400 D																			

Measures in millimeters [inches in brackets]

Motor type	Female shafts - Option code "F1" (standard DIN 5480)				Keyed shafts - Option code "P1"					
	m	n	o	p	q	r	s	t	u	v
MR 350 E	28 [1.10]	43 [1.69]	5.2 [0.20]	N47x2x22-9H	97 [3.82]	74 [2.91]	55 [2.17]	16 [0.63]	70 [2.76]	59 [2.32]
MR 400 E										
MR 450 E										
MRE 500 E										
MR 500 F	28 [1.10]	49 [1.93]	5.2 [0.20]	N55x3x17-9H	101 [3.98]	78 [3.07]	60 [2.36]	18 [0.71]	70 [2.76]	64 [2.52]
MR 600 F										
MR 700 F										
MRE 800 F										
MR 1100 G	38 [1.50]	58 [2.28]	8 [0.31]	N65x3x20-9H	117 [4.61]	88 [3.46]	70 [2.76]	20 [0.79]	80 [3.15]	74.5 [2.93]
MRE 1400 G										
MRA 1600 G										
MR 1600 H	47 [1.85]	65 [2.56]	8 [0.31]	N75x3x24-9H	132 [5.20]	100 [3.94]	80 [3.15]	22 [0.87]	90 [3.54]	85 [3.35]
MR 1800 H										
MRE 2100 H										
MRA 2400 H										
MR 2400 I	48 [1.89]	70 [2.76]	8 [0.31]	N85x3x27-9H	153 [6.02]	120 [4.72]	90 [3.54]	25 [0.98]	110 [4.33]	95 [3.74]
MR 2800 I										
MRE 3100 I										
MRA 3500 I										
MR 3600 L	50 [1.97]	82 [3.23]	14 [0.55]	N100x3x32-9H	210 [8.27]	173 [6.81]	110 [4.33]	28 [1.10]	160 [6.30]	116 [4.57]
MR 4100 L										
MR 4500 L										
MRE 5400 L										
MR 6500 M	50 [1.97]	90 [3.54]	14 [0.55]	N110x3x35-9H	230 [9.06]	188 [7.40]	124 [4.88]	32 [1.26]	180 [7.09]	138 ⁽¹⁾ [5.43] ⁽¹⁾
MR 7000 M										
MRE 7600 M										
MRE 8200 M										
MRA 9000 M										

⁽¹⁾ = Two keys at 180°. For frame size M, the dimension "v" refers to the distance between the two keys.

Shrink disks

Code	Output shaft
C1	Shrink disk coupling

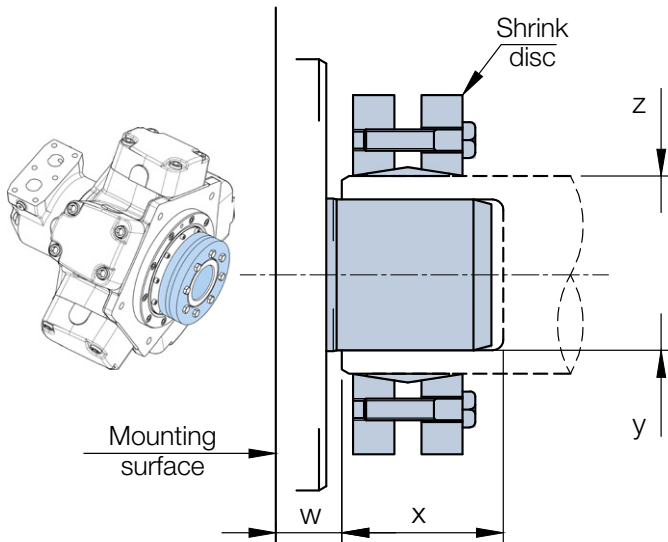

Shrink disk coupling - Option code "C1"				
Motor type	w	x	y	z
MR 350 E				
MR 400 E	25	80	55	68
MR 450 E	[0.98]	[3.15]	[2.17]	[2.68]
MRE 500 E				
MR 500 F				
MR 600 F	25	85	60	80
MR 700 F	[0.98]	[3.35]	[2.36]	[3.15]
MRE 800 F				
MR 1100 G	31	95	70	100
MRE 1400 G	[1.22]	[3.74]	[2.76]	[3.94]
MRA 1600 G				
MR 1600 H				
MR 1800 H	34	110	80	100
MRE 2100 H	[1.34]	[4.33]	[3.15]	[3.94]
MRA 2400 H				
MR 2400 I				
MR 2800 I	35	130	90	125
MRE 3100 I	[1.38]	[5.12]	[3.54]	[4.92]
MRA 3500 I				
MR 3600 L				
MR 4100 L	39	185	110	155
MR 4500 L	[1.54]	[7.28]	[4.33]	[6.10]
MRE 5400 L				
MR 6500 M				
MR 7000 M				
MRE 7600 M	44	200	125	165
MRE 8200 M	[1.73]	[7.87]	[4.92]	[6.50]
MRA 9000 M				

Shrink disk coupling - Option code "C1"				
Motor type	w	x	y	z
MR 33 A	19	45	30	36
MR 57 A	[0.75]	[1.77]	[1.18]	[1.42]
MR 73 B				
MR 93 B	26	50	35	44
MR 110 B	[1.02]	[1.97]	[1.38]	[1.73]
MR 125 C				
MR 160 C	19	55	40	50
MR 190 C	[0.75]	[2.17]	[1.57]	[1.97]
MR 200 D				
MR 250 D				
MR 300 D	23	65	50	68
MRE 330 D	[0.91]	[2.56]	[1.97]	[2.68]
MRA 400 D				

Measures in millimeters [inches in brackets]

Speed sensor connections

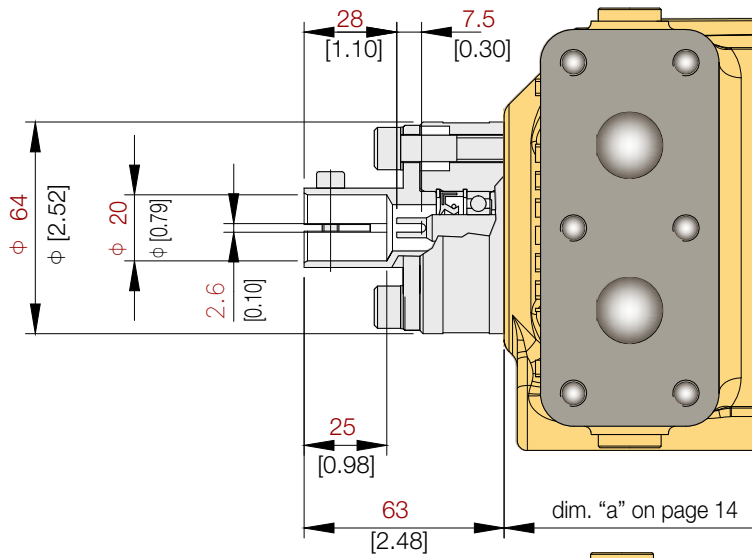

Speed sensor code	
C1	Connection for mechanical tachometer

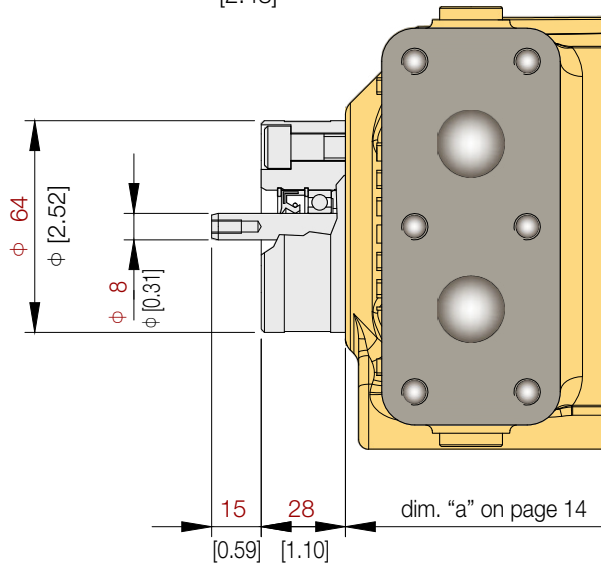

Speed sensor code	
Q1	Connection for encoder drive

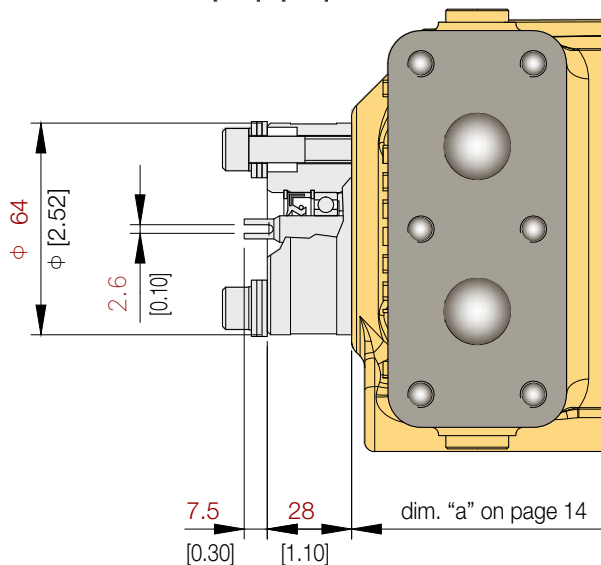

Speed sensor code	
T1	Connection for tachogenerator drive

Measures in millimeters [inches in brackets]

Incremental encoders

Code	Speed sensor
B1	Bidirectional incremental encoder
M1	Monodirectional incremental encoder

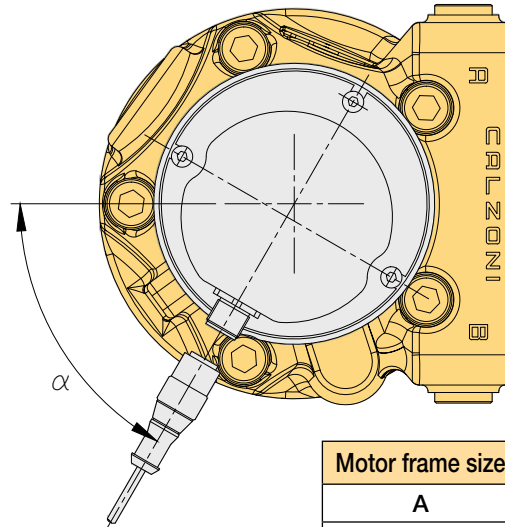
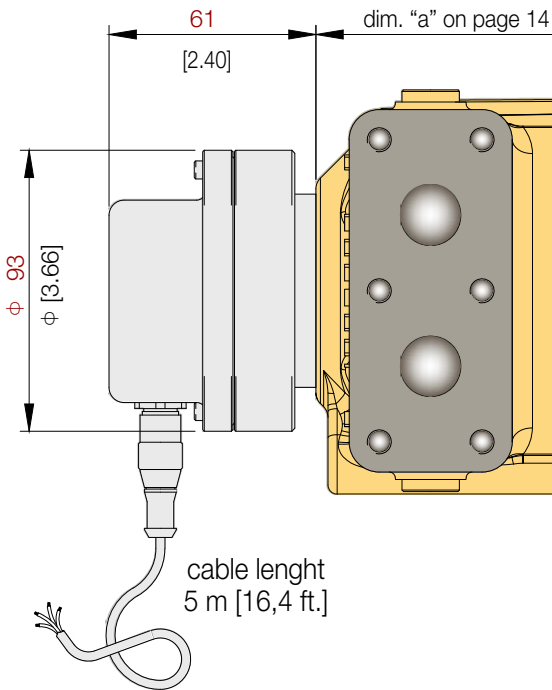
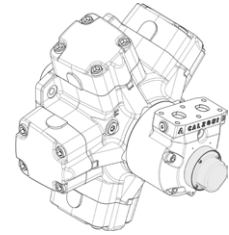

Motor frame size	α
A	126°
B, C, D, E, F	60°
G, H, I, L, M	45°

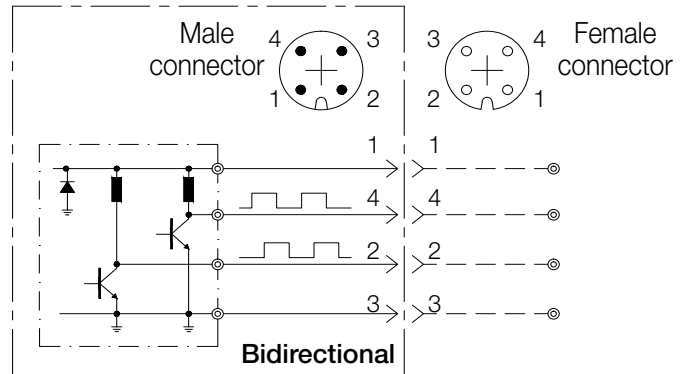
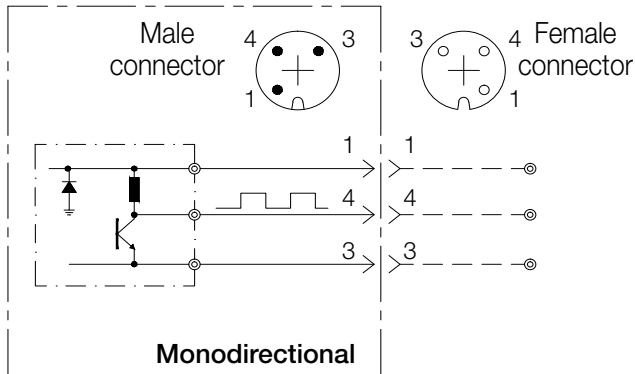

Color wires and function		
1	Brown	Power Supply
2	White	Output B phase
3	Blue	Power Supply
4	Black	Output A phase

Encoder type	Incremental (absolute on request)
Supply voltage	8 to 24 VDC
Current output	10 mA max
Output signal	A phase (MONODIRECTIONAL) A and B phase (BIDIRECTIONAL)
Number of pulses	500 (other on request)
Operating temperature	from 0°C to 70°C (from 32°F to 158 °F)
Protection degree	IP 67 (with protection and connection assembled)

Measures in millimeters [inches in brackets]

Six-bolt connections

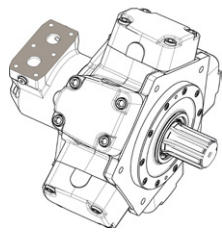

Code	Fluid connections
N1	Six-bolt connection (for manifold)

N.B.: the six-bolt connection can be used to easily assemble a manifold on the motor. Use the six threaded holes to fix the manifold on the motor.

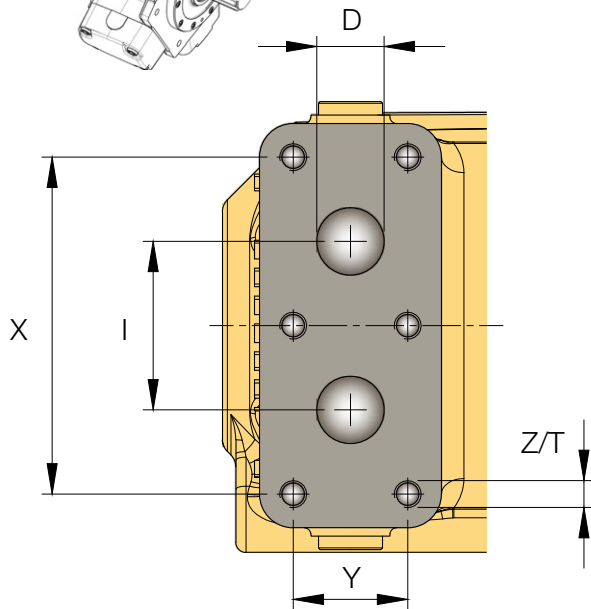

N.B.: Z/T = diameter/depth

Six-bolt connection - Option code "N1"					
Motor type	X	Y	I	D	Z / T
MR 33 A ⁽¹⁾	-	-	-	-	-
MR 57 A ⁽¹⁾	-	-	-	-	-
MR 73 B	100 [3.94]	34 [1.34]	50 [1.97]	20 [0.79]	M8 / 15
MR 93 B					
MR 110 B					
MR 125 C					
MR 160 C					
MR 190 C					
MR 200 D					
MR 250 D					
MR 300 D					
MRE 330 D					
MRA 400 D					

Six-bolt connection - Option code "N1"					
Motor type	X	Y	I	D	Z / T
MR 350 E	120 [4.72]	40 [1.57]	61 [2.4]	25 [0.98]	M10 / 18
MR 400 E					
MR 450 E					
MRE 500 E					
MR 500 F	120 [4.72]	40 [1.57]	61 [2.4]	25 [0.98]	M10 / 18
MR 600 F					
MR 700 F					
MRE 800 F					
MR 1100 G	136 [5.35]	50 [1.97]	73 [2.87]	31 [1.22]	M12 / 21
MRE 1400 G					
MRA 1600 G					
MR 1600 H					
MR 1800 H					
MRE 2100 H					
MRA 2400 H					
MR 2400 I	180 [7.09]	62 [2.44]	86 [3.39]	37 [1.46]	M14 / 28
MR 2800 I					
MRE 3100 I					
MRA 3500 I	200 [7.87]	68 [2.68]	116 [4.57]	38 [1.50]	M16 / 28
MR 3600 L					
MR 4100 L					
MR 4500 L					
MRE 5400 L					
MR 6500 M					
MR 7000 M					
MRE 7600 M					
MRE 8200 M					
MRA 9000 M					

⁽¹⁾ = Not available. See page 26 for alternative option.

Measures in millimeters [inches in brackets]

SAE high pressure connections

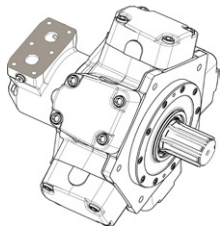

Code	Fluid connections
G3	High pressure SAE metric (6000 psi)
L3	High pressure SAE UNC (6000 psi)

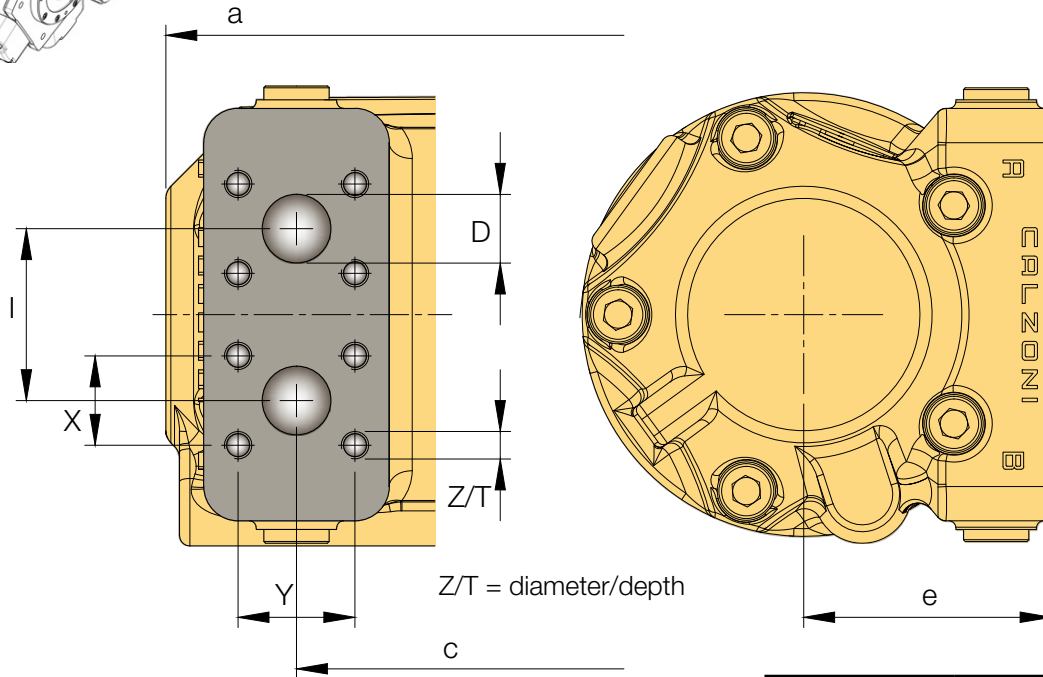

High pressure (6000 PSI)	
Option code "G3" (SAE metric)	Option code "L3" (SAE UNC)

Motor type	a	c	D	e	l	X	Y	Z/T	Z/T
MR 73 B	219 [8.62]	189 [7.44]	19 [0.75]	96 [3.78]	75 [2.95]	50.8 [2.00]	23.8 [0.94]	M10 / 25	3/8-16UNC-2B / 0.98
MR 93 B									
MR 110 B									
MR 125 C									
MR 160 C									
MR 190 C									
MR 200 D	232.5 [9.15]	202.5 [7.97]							
MR 250 D									
MR 300 D									
MRE 330 D									
MRA 400 D									

Measures in millimeters [inches in brackets]

Motor type	a	c	D	e	l	X	Y	High pressure (6000 PSI)	
								Option code "G3" (SAE metric)	Option code "L3" (SAE UNC)
								Z/T	Z/T
MR 350 E	274.5 [10.81]	244.5 [9.63]	19 [0.75]	96 [3.78]	75 [2.95]	50.8 [2.00]	23.8 [0.94]	M10 / 25	3/8-16UNC-2B / 0.98
MR 400 E									
MR 450 E									
MRE 500 E									
MR 500 F									
MR 600 F									
MR 700 F									
MRE 800 F									
MR 1100 G ⁽¹⁾	-	-	-	-	-	-	-	-	-
MRE 1400 G ⁽¹⁾									
MRA 1600 G ⁽¹⁾									
MR 1600 H ⁽¹⁾									
MR 1800 H ⁽¹⁾									
MRE 2100 H ⁽¹⁾									
MRA 2400 H ⁽¹⁾									
MR 2400 I	466 [18.35]	392 [15.43]	37 [1.46]	123 [4.84]	101 [3.98]	36.5 [1.44]	79.4 [3.13]	M16 / 35	5/8-11UNC-2B / 1.38
MR 2800 I									
MRE 3100 I									
MRA 3500 I									
MR 3600 L	489.5 [19.27]	418.5 [16.48]	50 [1.97]	105 [4.13]	116 [4.57]	44.45 [1.75]	96.8 [3.81]	M20 / 34	3/4-10UNC-2B / 1.38
MR 4100 L									
MR 4500 L									
MRE 5400 L									
MR 6500 M									
MR 7000 M	566 [22.28]	495 [19.49]	50 [1.97]	105 [4.13]	116 [4.57]	44.45 [1.75]	96.8 [3.81]	M20 / 34	3/4-10UNC-2B / 1.38
MRE 7600 M									
MRE 8200 M									
MRA 9000 M									

⁽¹⁾ = Not available. See page 28 for alternative option.

Measures in millimeters [inches in brackets]



SAE standard pressure adaptors

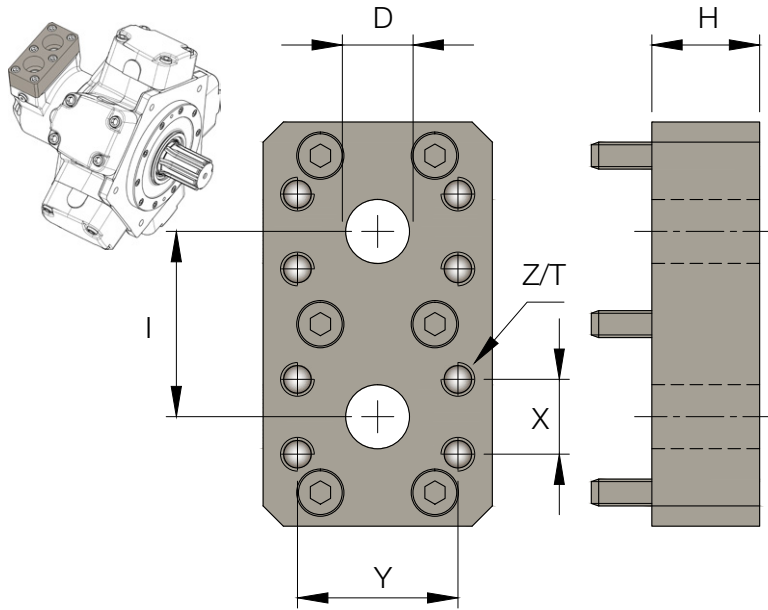

Code	Fluid connections
S1	Standard pressure SAE metric
T1	Standard pressure SAE UNC

N.B.: the flange is supplied complete with screws and seals, already assembled on the standard motor six-bolts connection (code N1).

N.B.: Z/T = diameter/depth

Standard pressure	
Option code "S1" (SAE metric)	Option code "T1" (SAE UNC)

Motor type	SAE PSI	H	D	I	X	Y	Z/T	Z/T
MR 33 A	5000	0 ⁽¹⁾	25	65	26.2	52.4	M10 / 25	
MR 57 A			[0.98]	[2.56]	[1.03]	[2.06]		
MR 73 B	5000	38 [1.50]	19 [0.75]	55 [2.16]	22.2 [0.87]	47.6 [1.87]	M10 / 25	3/8-16UNC-2B / 0.98
MR 93 B								
MR 110 B								
MR 125 C								
MR 160 C								
MR 190 C								
MR 200 D								
MR 250 D								
MR 300 D								
MRE 330 D								
MRA 400 D								
MR 350 E	5000	39 [1.53]	25 [0.98]	62 [2.44]	26.2 [1.03]	52.4 [2.06]	M10 / 25	3/8-16UNC-2B / 0.98
MR 400 E								
MR 450 E								
MRE 500 E								

⁽¹⁾ = Integrated into rotary valve housing.

Measures in millimeters [inches in brackets]

Motor type	SAE PSI	H	D	I	X	Y	Standard pressure	
							Option code "S1" (SAE metric)	Option code "T1" (SAE UNC)
							Z/T	Z/T
MR 500 F	5000	39 [1.53]	25 [0.98]	62 [2.44]	26.2 [1.03]	52.4 [2.06]	M10 / 25	3/8-16UNC-2B / 0.98
MR 600 F								
MR 700 F								
MRE 800 F								
MR 1100 G	4000	45 [1.77]	31 [1.22]	75 [2.95]	30.2 [1.19]	58.7 [2.31]	M10 / 25	7/16-14UNC-2B / 1.18
MRE 1400 G								
MRA 1600 G								
MR 1600 H								
MR 1800 H								
MRE 2100 H								
MRA 2400 H								
MR 2400 I	3000	59 [2.32]	37 [1.46]	86 [3.39]	35.7 [1.40]	69.8 [2.75]	M12 / 30	1/2-13UNC-2B / 1.18
MR 2800 I								
MRE 3100 I								
MRA 3500 I								
MR 3600 L	3000	58 [2.28]	50 [1.97]	112 [4.41]	42.9 [1.69]	77.8 [3.06]	M12 / 30	1/2-13UNC-2B / 1.18
MR 4100 L								
MR 4500 L								
MRE 5400 L								
MR 6500 M								
MR 7000 M								
MRE 7600 M								
MRE 8200 M								
MRA 9000 M								

6

Measures in millimeters [inches in brackets]



SAE high pressure adaptors

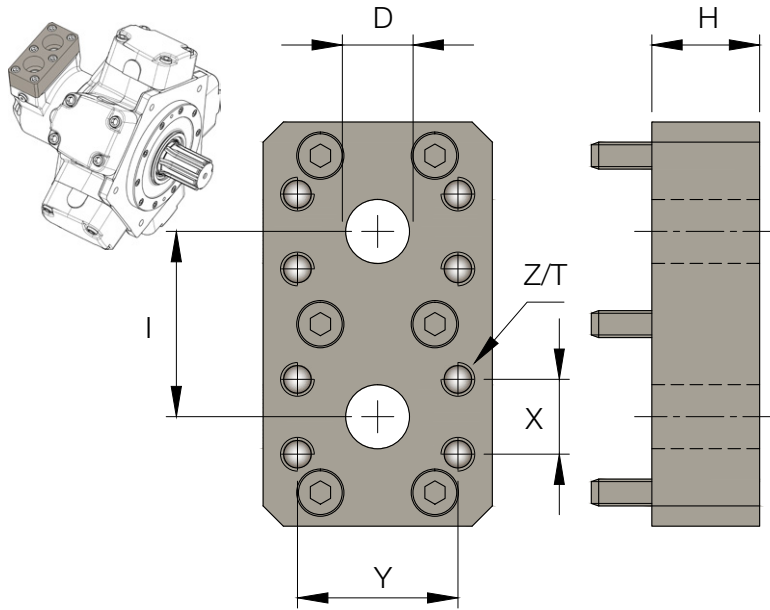

Code	Fluid connections
G1	High pressure SAE metric (6000 psi)
L1	High pressure SAE UNC (6000 psi)

N.B.: the flange is supplied complete with screws and seals, already assembled on the standard motor six-bolts connection (code N1).

Z/T = diameter/depth

High pressure	
Option code "G1" (SAE metric)	Option code "L1" (SAE UNC)
Z/T	Z/T

Motor type	SAE PSI	H	D	I	X	Y	Z/T	Z/T
MR 1100 G	6000	45 [1.77]	25 [0.98]	71 [2.79]	27.8 [1.09]	57.15 [2.25]	M12 / 30	7/16-14UNC-2B / 1.18
MRE 1400 G								
MRA 1600 G								
MR 1600 H								
MR 1800 H								
MRE 2100 H								
MRA 2400 H								
MR 2400 I	6000	59 [2.32]	37 [1.46]	100 [3.94]	36.5 [1.44]	79.4 [3.13]	M16 / 30	5/8-11UNC-2B / 1.38
MR 2800 I								
MRE 3100 I								
MRA 3500 I								
MR 3600 L	6000	58 [2.28]	50 [1.97]	116 [4.57]	44.45 [1.75]	96.8 [3.81]	M20 / 35	3/4-10UNC-2B / 1.50
MR 4100 L								
MR 4500 L								
MRE 5400 L								
MR 6500 M								
MR 7000 M								
MRE 7600 M								
MRE 8200 M								
MRA 9000 M								

Measures in millimeters [inches in brackets]

BSP threads adaptors

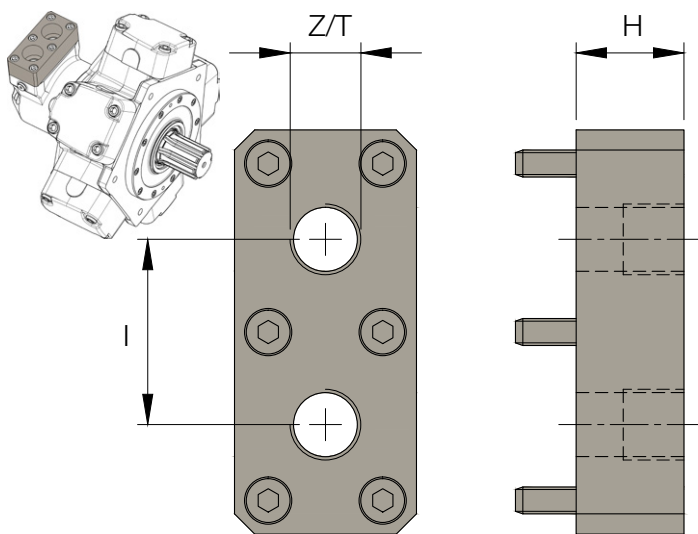

Code	Fluid connections
C1	BSP threads (according to ISO 228/1)

N.B.: the flange is supplied complete with screws and seals, already assembled on the standard motor six-bolts connection (code N1).

Z/T = diameter/depth

BSP threads flange - Option code "C1"			
Motor type	Z / T	H	I
MR 33 A	-	-	-
MR 57 A	-	-	-
MR 73 B	G 3/4" / 18	38 [1.50]	50 [1.97]
MR 93 B			
MR 110 B			
MR 125 C			
MR 160 C			
MR 190 C			
MR 200 D	G 1 1/4" / 22	39 [1.53]	60 [2.36]
MR 250 D			
MR 300 D			
MRE 330 D			
MRA 400 D			
MR 350 E			
MR 400 E	G 2" / 28	58 [2.28]	112 [4.41]
MR 450 E			
MRE 500 E			
MRE 7600 M			
MRE 8200 M			

BSP threads flange - Option code "C1"			
Motor type	Z / T	H	I
MR 500 F	G 1 1/4" / 22	39 [1.53]	60 [2.36]
MR 600 F			
MR 700 F			
MRE 800 F			
MR 1100 G	G 1 1/2" / 25	45 [1.77]	71 [2.79]
MRE 1400 G			
MRA 1600 G			
MR 1600 H			
MR 1800 H			
MRE 2100 H			
MRA 2400 H	G 1 1/2" / 25	59 [2.32]	86 [3.39]
MR 2400 I			
MR 2800 I			
MRE 3100 I			
MRA 3500 I	G 2" / 28	58 [2.28]	112 [4.41]
MR 3600 L			
MR 4100 L			
MR 4500 I			
MRE 5400 L			
MR 6500 M			
MR 7000 M			
MRE 7600 M			
MRE 8200 M			
MRA 9000 M			

Measures in millimeters [inches in brackets]

Parking brake

The parking brake is a “spring applied - hydraulic pressure release” multi-disc brake, that has been designed for those applications where it is necessary to hold the system under an external torque without pressure feeding (the brake can be used in dynamic conditions only in case of emergency).

Hydraulic pressure is required to “hold off” the brake. During normal operation the brake is pressurized in the released position, while the maximum braking torque is achieved when the brake is not fed. Any function which reduces the hydraulic system below the release pressure of the brake will cause the brake to be activated.

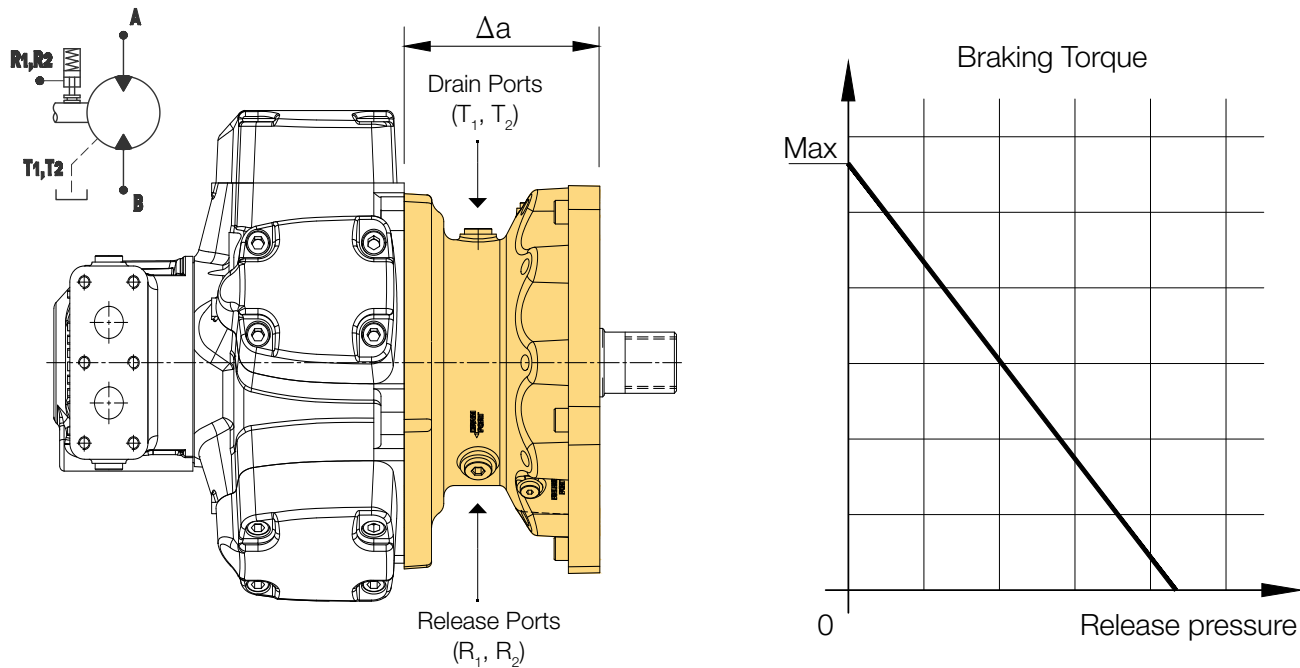

The release pressure represents the pressure value to completely release the brake (no braking torque).

In case of hydraulic motor equipped with parking brake, the brake length (Δa) and the brake mass (Δm) have to be added to the correspondig motor values (without brake) to calculate the total lenght and mass.

Motor type	Δa	Δm	Static Braking Torque ($\mu=0.14$)		Dynamic Braking Torque ($\mu=0.09$)		Release Pressure
			Max	Min	Max	Min	
MR 125 C	135 mm 5.3 in	27 kg 59 lb	1500 N·m	1400 N·m	1000 N·m	900 N·m	30 bar 435 psi
MR 160 C			1100 lbf·ft	1030 lbf·ft	730 lbf·ft	660 lbf·ft	
MR 190 C		29 kg 64 lb	1900 N·m 1400 lbf·ft	1700 N·m 1250 lbf·ft	1200 N·m 880 lbf·ft	1100 N·m 810 lbf·ft	
MR 200 D							
MR 250 D							
MR 300 D							
MRE 330 D							
MRA 400 D							

Motor type	Δa	Δm	Static Braking Torque ($\mu=0.14$)		Dynamic Braking Torque ($\mu=0.12$)		Release Pressure
			Max	Min	Max	Min	
MR 350 E	172 mm 18.6 in	69 kg 152 lb	3200 N·m	2900 N·m	2100 N·m	1900 N·m	30 bar 435 psi
MR 400 E			2360 lbf·ft	2140 lbf·ft	1550 lbf·ft	1400 lbf·ft	
MR 450 E							
MRE 500 E		75 kg 165 lb	4500 N·m	4000 N·m	2900 N·m	2700 N·m	
MR 600 F			3320 lbf·ft	2950 lbf·ft	2140 lbf·ft	1990 lbf·ft	
MR 700 F							
MRE 800 F							
MR 1100 G	193 mm 7.6 in	78 kg 172 lb	7100 N·m	6000 N·m	4500 N·m	4100 N·m	
MRE 1400 G			5240 lbf·ft	4420 lbf·ft	3320 lbf·ft	3020 lbf·ft	
MRA 1600 G							
MR 1600 H	211 mm 8.3 in	176 kg 388 lb	12000 N·m	10300 N·m	7700 N·m	7000 N·m	27 bar 392 psi
MR 1800 H			8850 lbf·ft	7600 lbf·ft	5680 lbf·ft	5160 lbf·ft	
MRE 2100 H							
MRA 2400 H							
MR 2400 I	222 mm 8.74 in	225 kg 496 lb	18300 N·m	15200 N·m	11700 N·m	10400 N·m	30 bar 435 psi
MR 2800 I			13500 lbf·ft	11210 lbf·ft	8630 lbf·ft	7670 lbf·ft	
MRE 3100 I							
MRA 3500 I							
MR 3600 L	287 mm 11.3 in	460 kg 1014 lb	30800 N·m	27000 N·m	19800 N·m	18200 N·m	30 bar 435 psi
MR 4100 L			22720 lbf·ft	19910 lbf·ft	14600 lbf·ft	13420 lbf·ft	
MR 4500 L							
MRE 5400 L							
MR 6500 M	340 mm 13.4 in	652 kg 1437 lb	46200 N·m	37900 N·m	29700 N·m	26100 N·m	
MR 7000 M			34070 lbf·ft	27950 lbf·ft	21900 lbf·ft	19250 lbf·ft	
MRE 7600 M							
MRE 8200 M							
MRA 9000 M							

Important notes:

- For correct braking operations, the hydraulic release pressure to the brake must fall to zero. Any residual release back pressure applied to the brake degrades braking torque and may result in hazardous conditions;
- Please contact Parker Hannifin in case axial or radial loads are be applied to the brake shaft;
- Refer to catalogue HY29-0504 for complete brakes list and options.

Mineral-oil based fluids

Performance data of this catalogue is valid when motors are operating with mineral oil based fluids, according to DIN 51525. The fluid should contain anti-oxidant, antifoam, demulsifying and antiwear or EP additives.

The viscosity, quality and cleanliness of operating fluids are decisive factors in determining the reliability, performance and life-time of an hydraulic component.

The maximum life-time and performance are achieved within the recommended viscosity range of 30 - 50 cSt. For applications that go beyond this range, we recommend to contact the manufacturer of the motor.

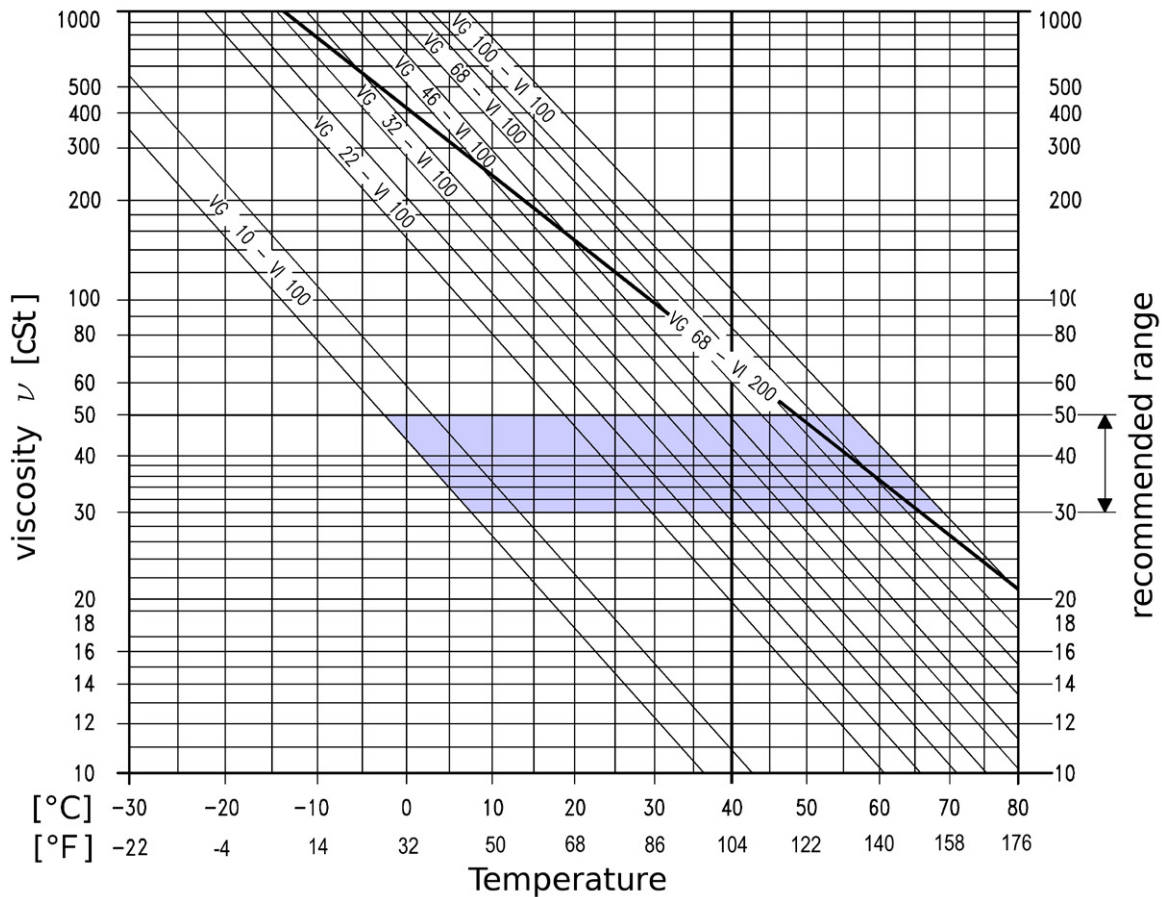

The viscosity refers both to the temperature of the fluid entering the motor and to the temperature inside the motor housing (case temperature). Based on the maximum operating temperature, we recommend to select the fluid so that its viscosity remains within the recommended viscosity range.

For critical operation conditions the following values apply:

- $\nu_{min,peak}$ = 10 cSt in emergency, short term;
- $\nu_{min,cont.}$ = 18 cSt for continuous operation at reduced performances;
- $\nu_{max.}$ = 1000 cSt short term upon cold start.

The drain oil temperature is influenced by pressure and speed and is usually higher than the circuit temperature or the tank temperature. At no point in the motor, however, may the temperature be higher than 80°C (max admitted temperature).

In case of operating conditions with high oil temperature or high ambient temperature, we recommend to use “FPM”

seals (option code “V1”). These “FPM” seals should be also used with HFD fluids.

If these viscosity requirements cannot be met, due to extreme operating parameters or high environment temperature, motor case flushing is strictly recommended in order to operate within the viscosity limits.

Should it be absolutely necessary to use a viscosity exceeding the recommended range, please contact Parker Hannifin / Calzoni Division.

Filtration improves the cleanliness level of the hydraulic fluid and increases the service life of the motor. To ensure the functional reliability of the motor, a cleanliness level of at least 20/18/15 to ISO 4406 is to be maintained in the circuit.

Other fluids

Parker radial piston motors can operate successfully on a wide variety of fluids. As a general guide de-rating factors are set out below:

Class	Description	Pressure	Speed	Power	Temperature	
					Max	Ideal
-	-	(% of nominal pressure)	(% of max speed)	(% of max power)		
HFA	Oil-water emulsion	50	50	25	50 °C 122 °F	40 °C 104 °F
HFB	Water-oil emulsion	80	80	60	60 °C 140 °F	45 °C 113 °F
HFC	Water-based solution (mostly with glycol)	60	60	30	60 °C 140 °F	45 °C 113 °F
HFD	Synthetic fluids (water free)	100	100	100	80 °C 176 °F	50 °C 122 °F



The use of synthetic fluids (type HFD) is allowed with motors supplied with seals in “FPM” material (pls. contact Parker Calzoni about the use of motors with synthetic fluids). The use of synthetic fluids (type HFD) does not imply any motor performances reduction.

Please specify make and type of fluid on your order if other than petroleum oil.

The below diagrams show, for each motor, the estimated motor working parameters corresponding to the requested values of speed (x-axis) and torque (ordinate axis). All the values are related to a mineral oil at 36 cSt viscosity and a fluid temperature of 45° C (113°F), with no pressure in the return line.

Each diagram has the following label definitions:

1. Maximum output power (with and without flushing);
2. Intermittent operating area (see definitions on pages 9 and 11);
3. Continuous operating area with flushing;
4. Continuous operating area without flushing;
5. Constant pressure curves.

For each motor, the curves in blue color in the left diagrams refer to the motor total efficiency η_T , and the curves in light blue color in the right diagrams refer to the volumetric efficiency η_V . The estimated mechanical efficiency η_M can be calculated by dividing the total efficiency by the volumetric efficiency value ($\eta_M = \eta_T / \eta_V$).

MR33A

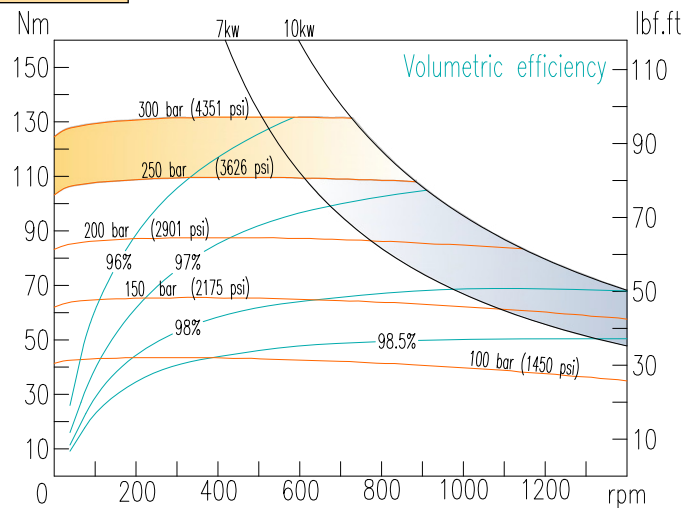
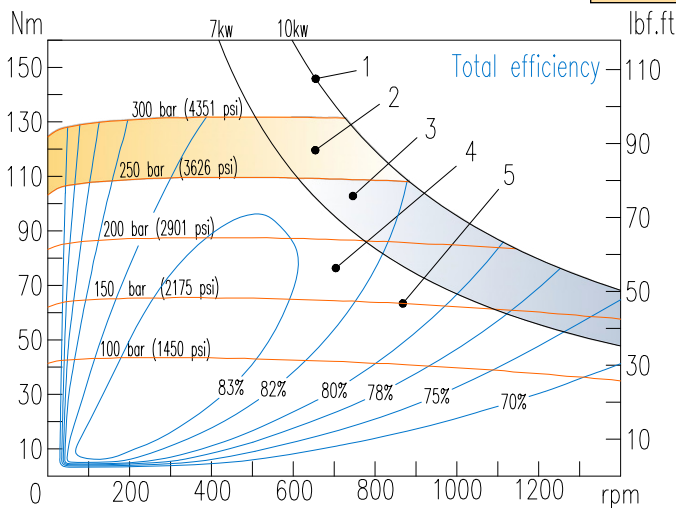

MR57A

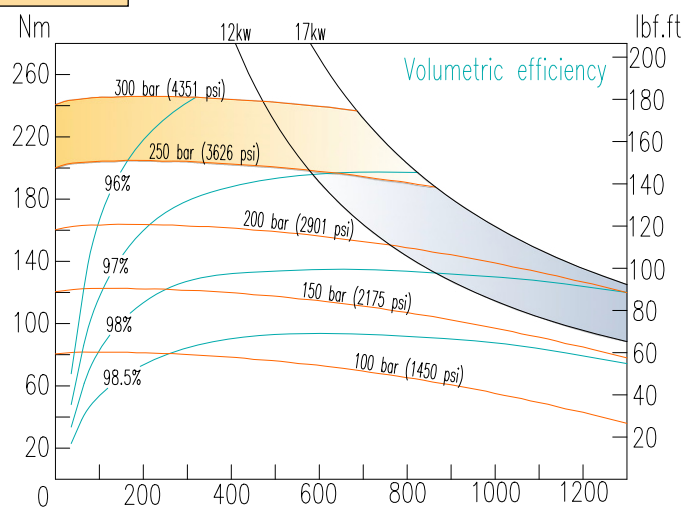
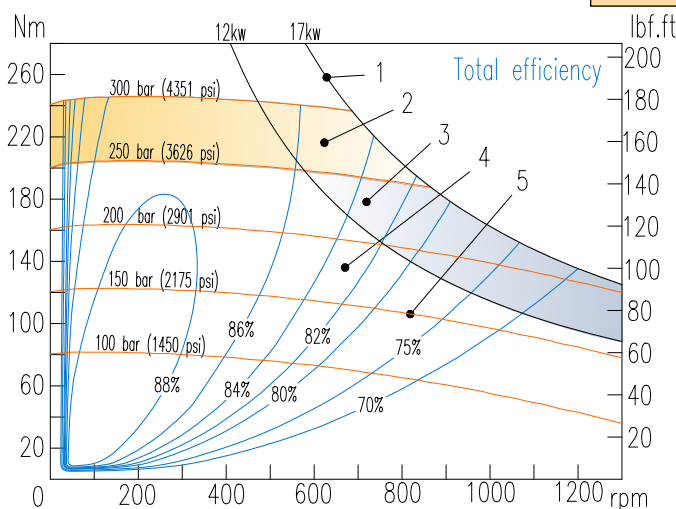

MR73B

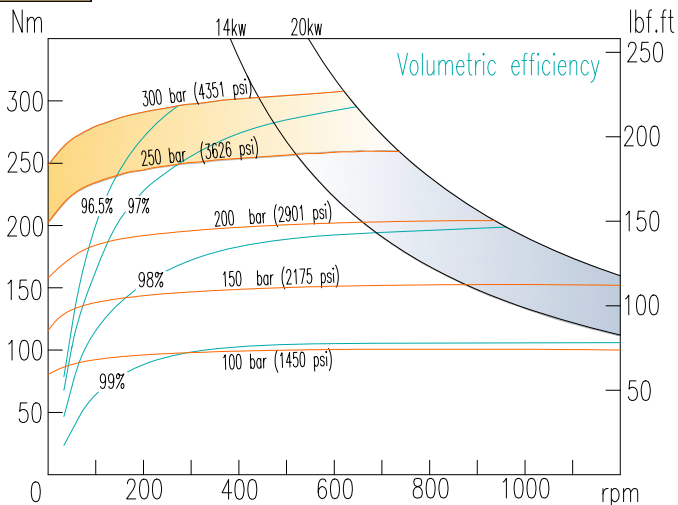
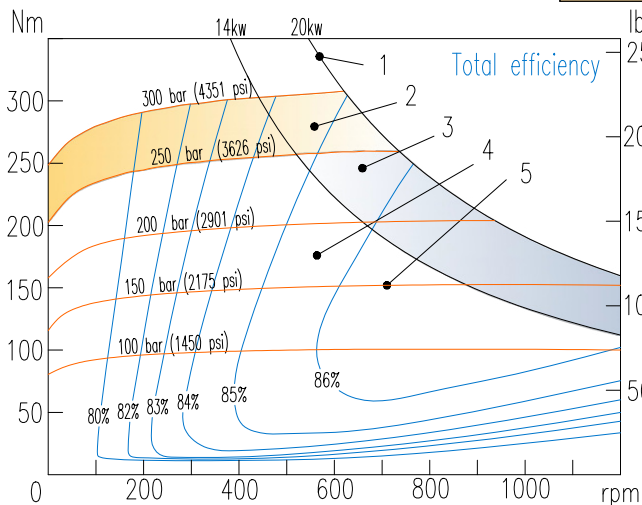

MR93B

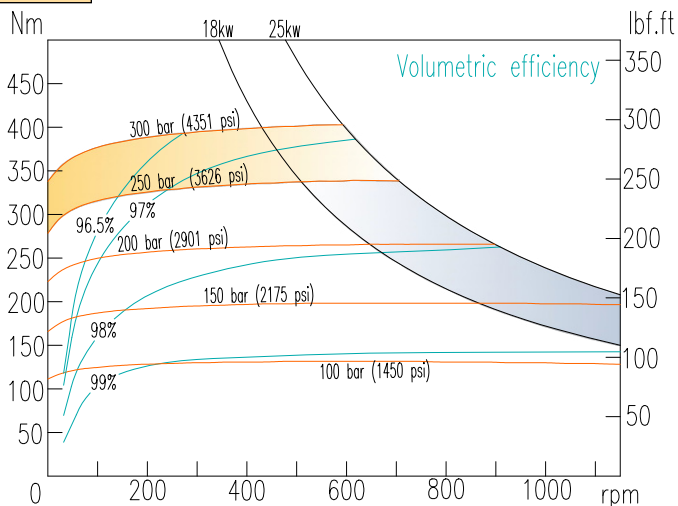
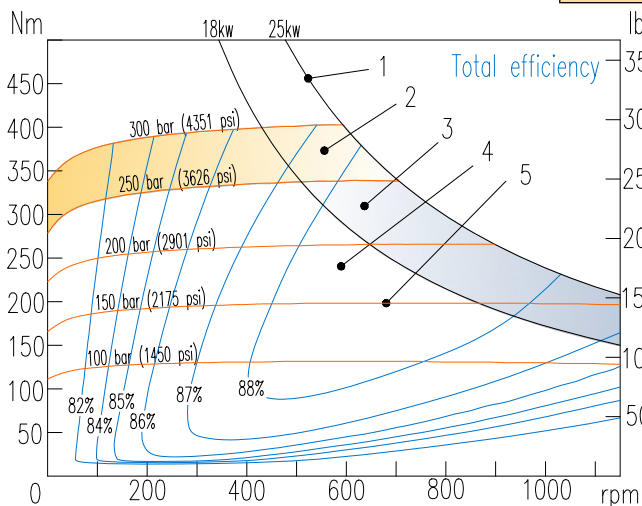

MR110B

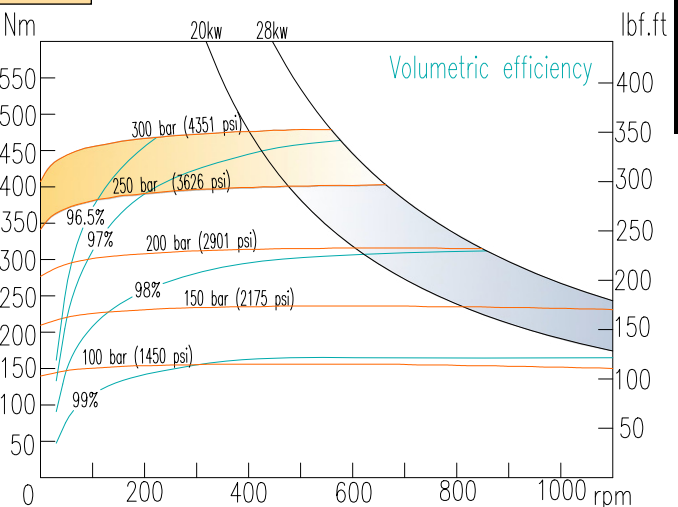
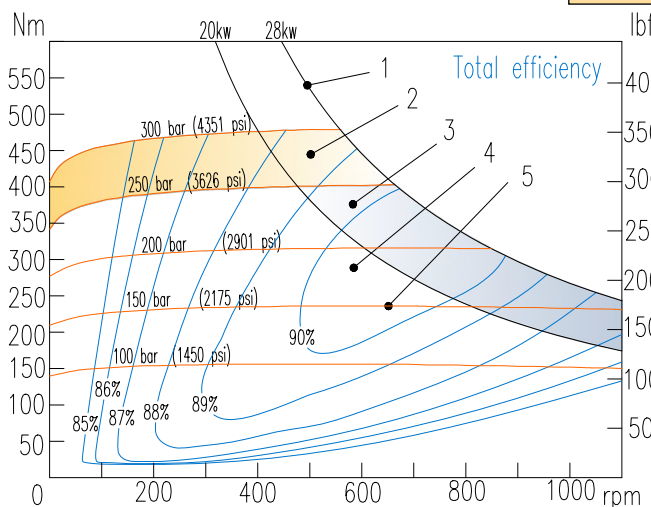

MR125C

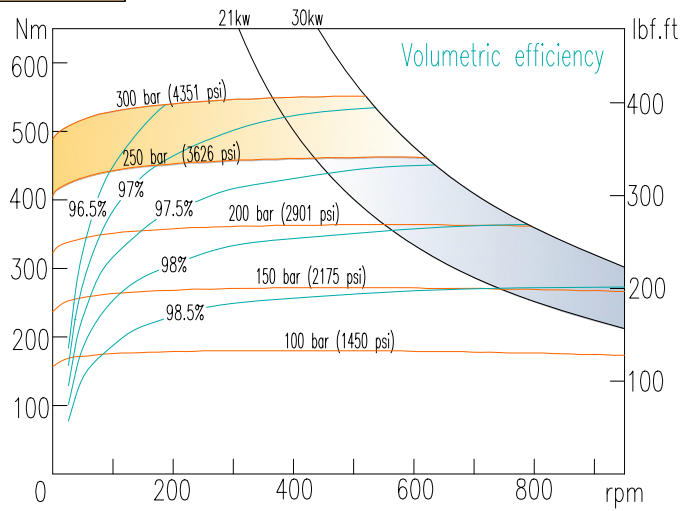
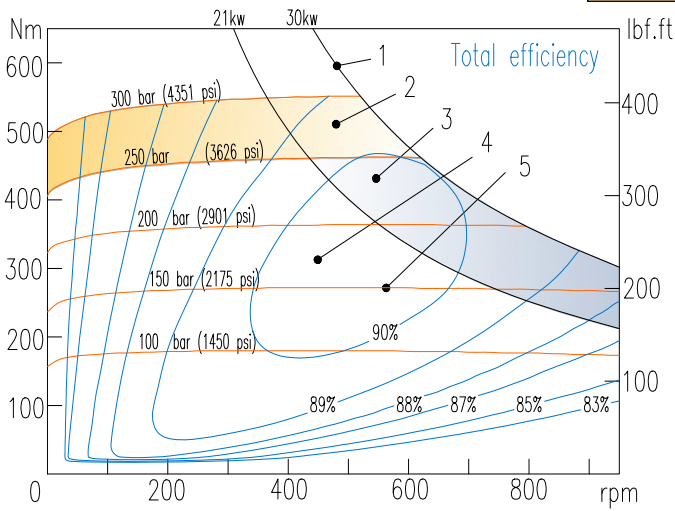

MR160C

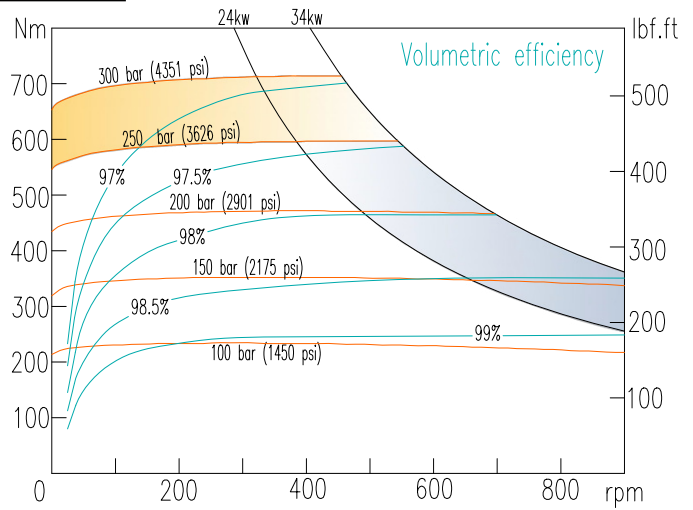
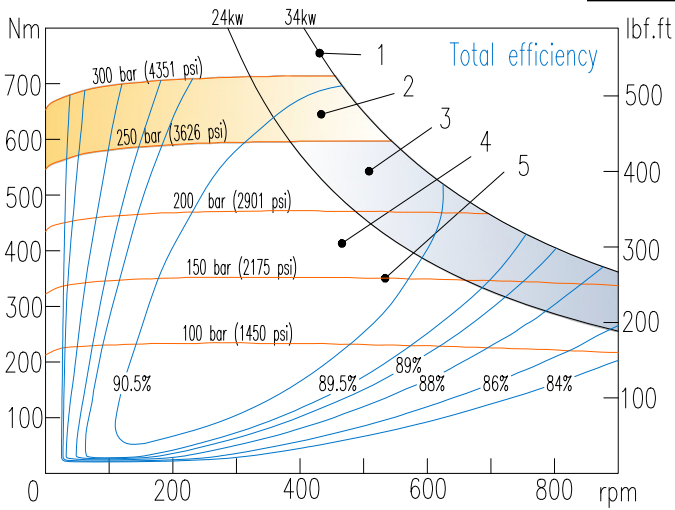

MR190C

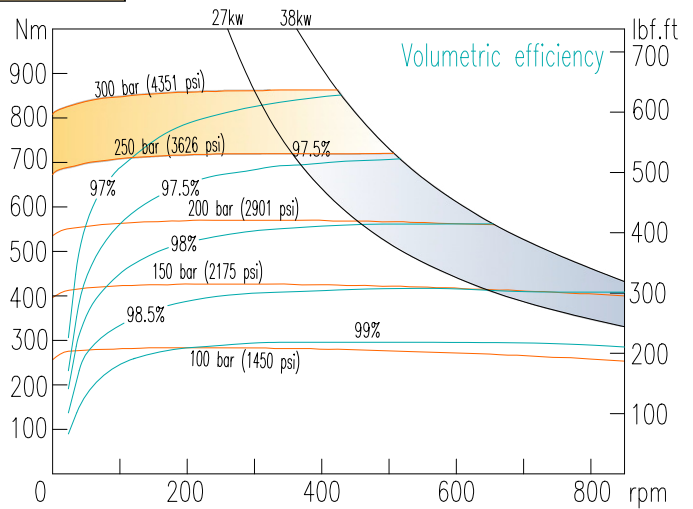
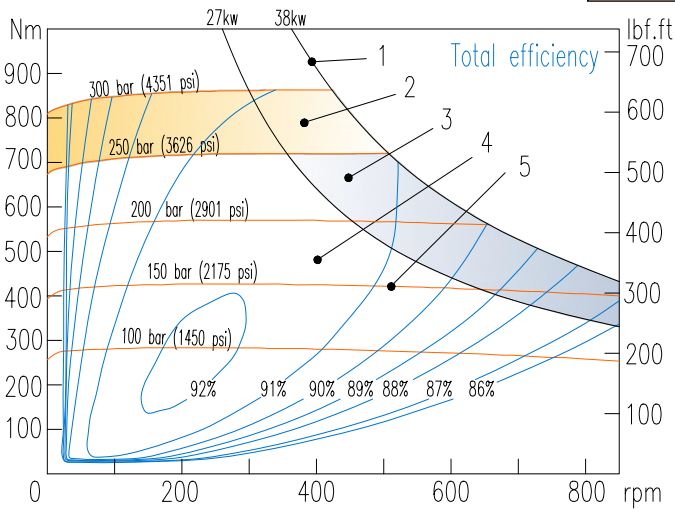

MR200D

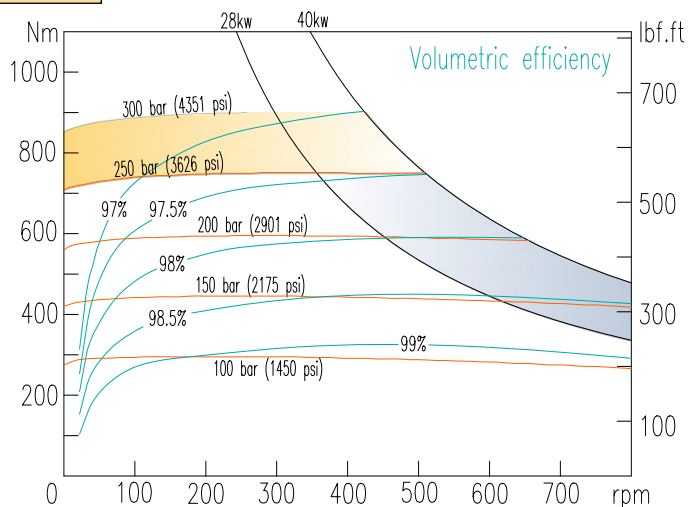
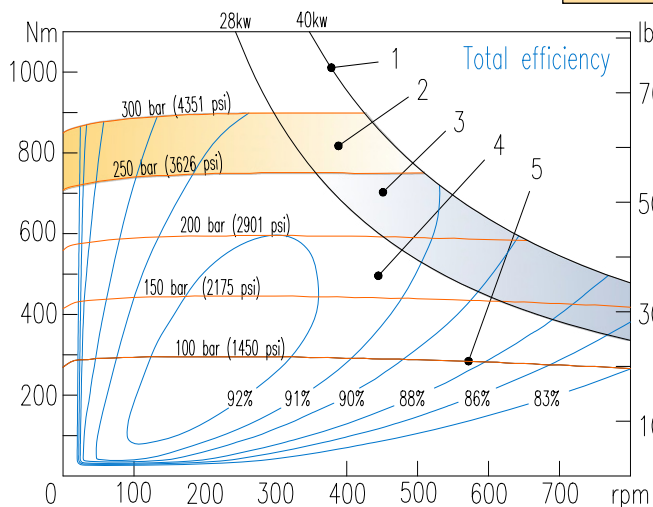

MR250D

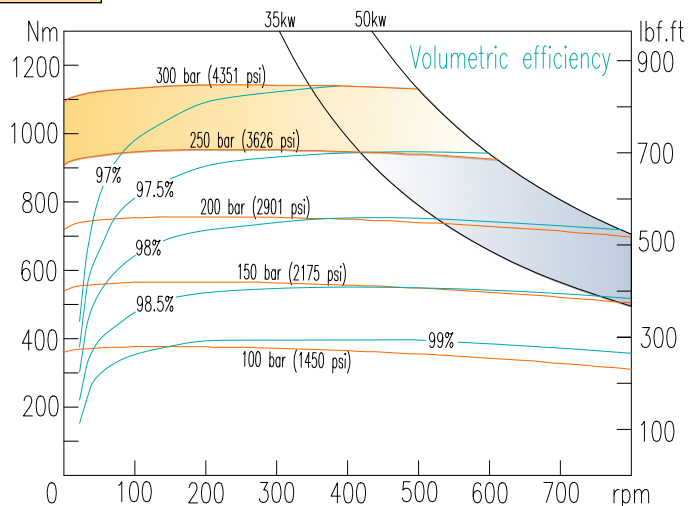
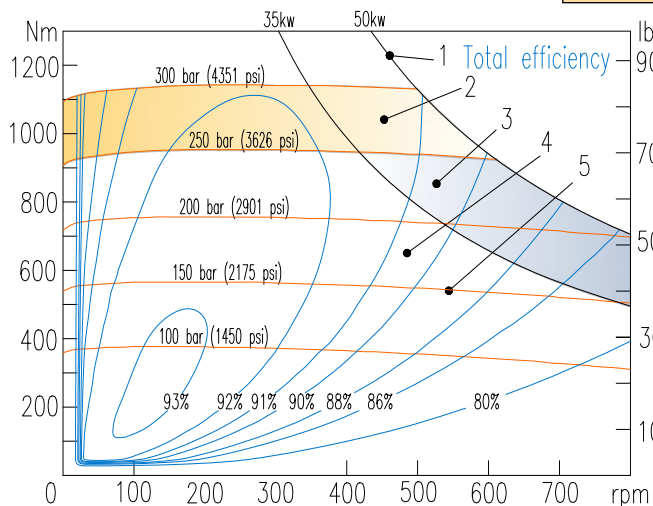

MR300D

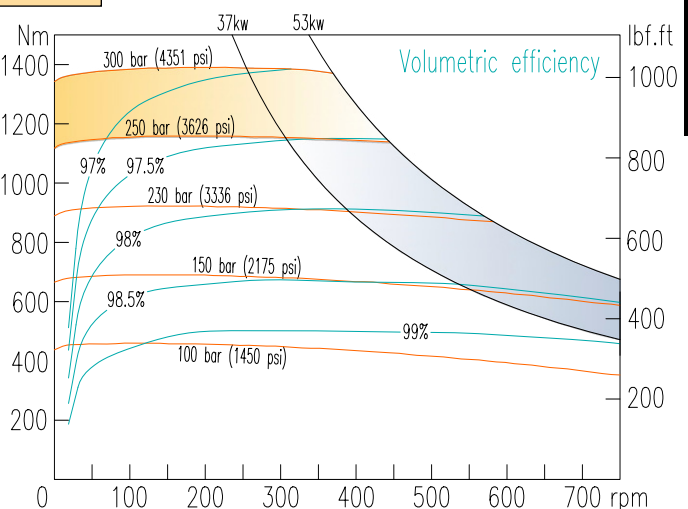
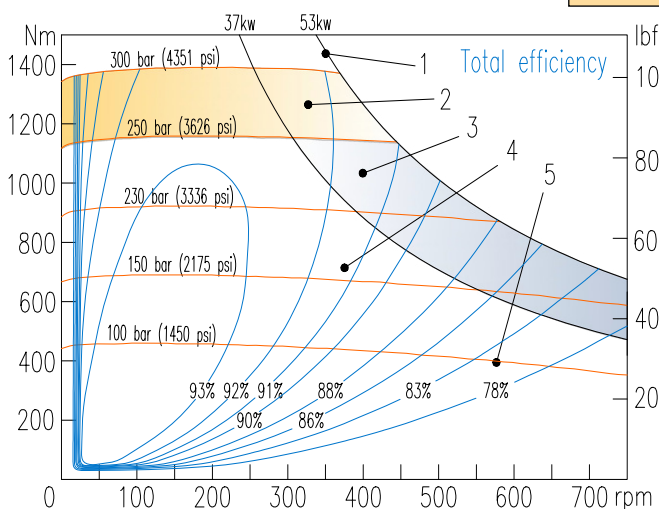

MRE330D

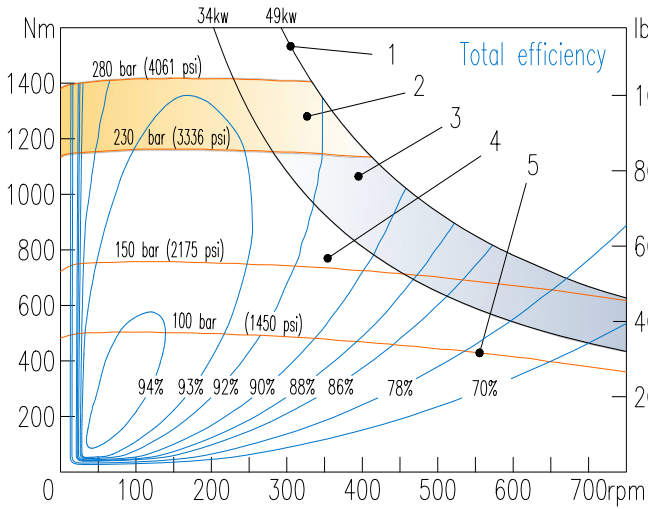

MRA400D

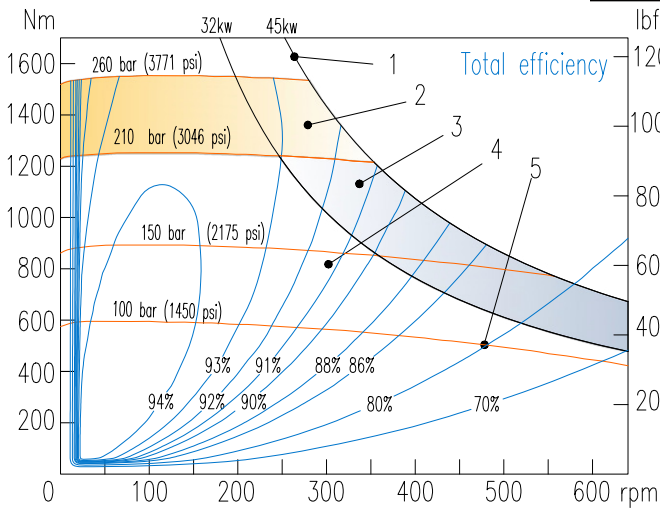

MR350E

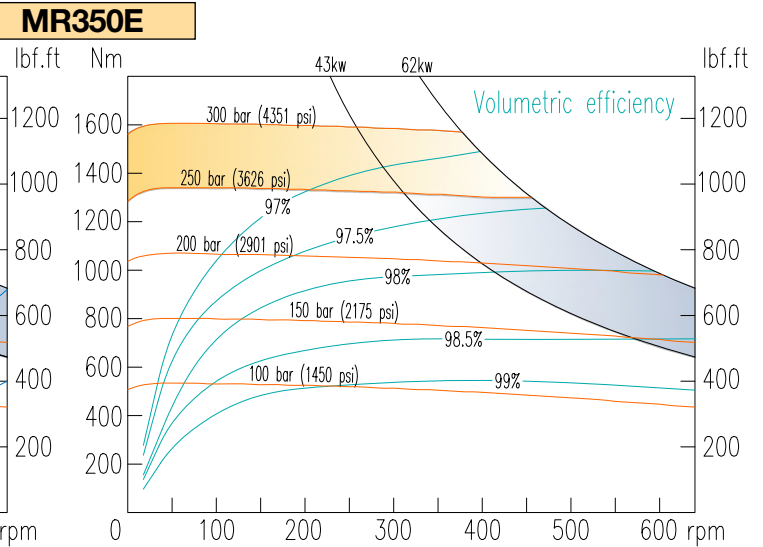
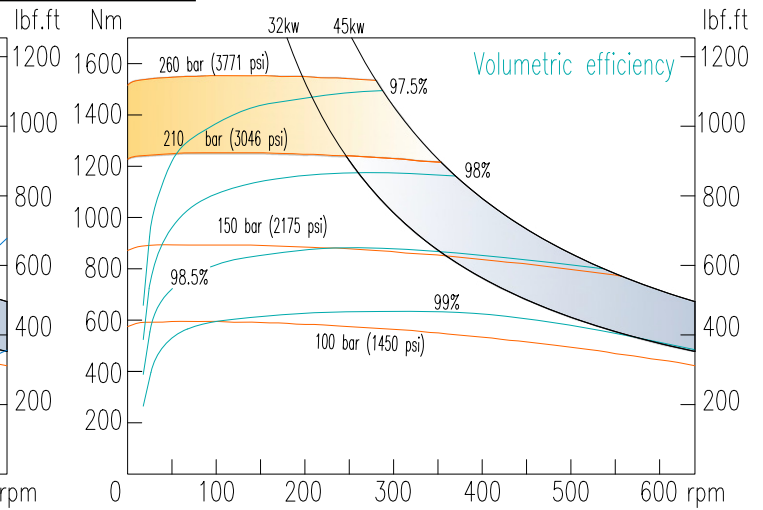
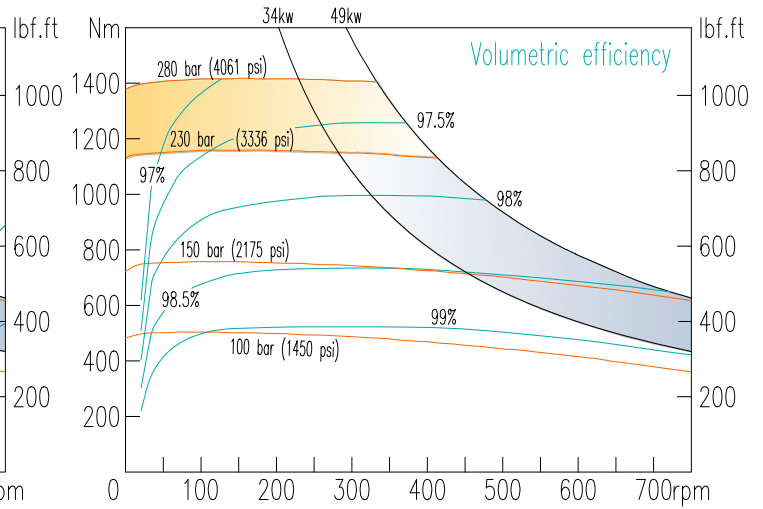
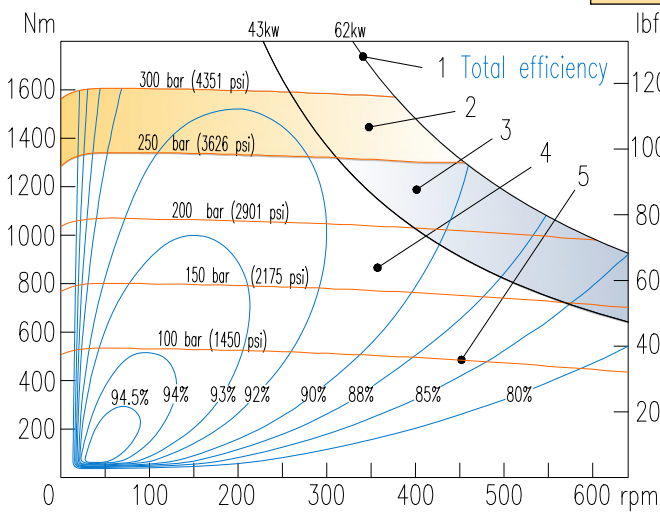

MR400E

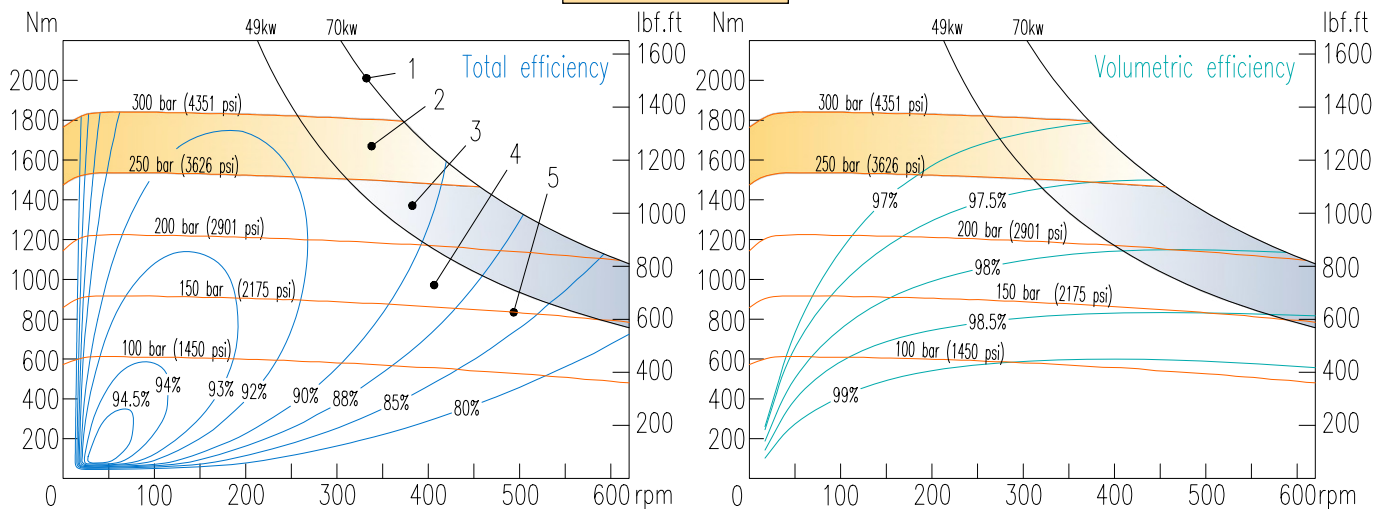

MR450E

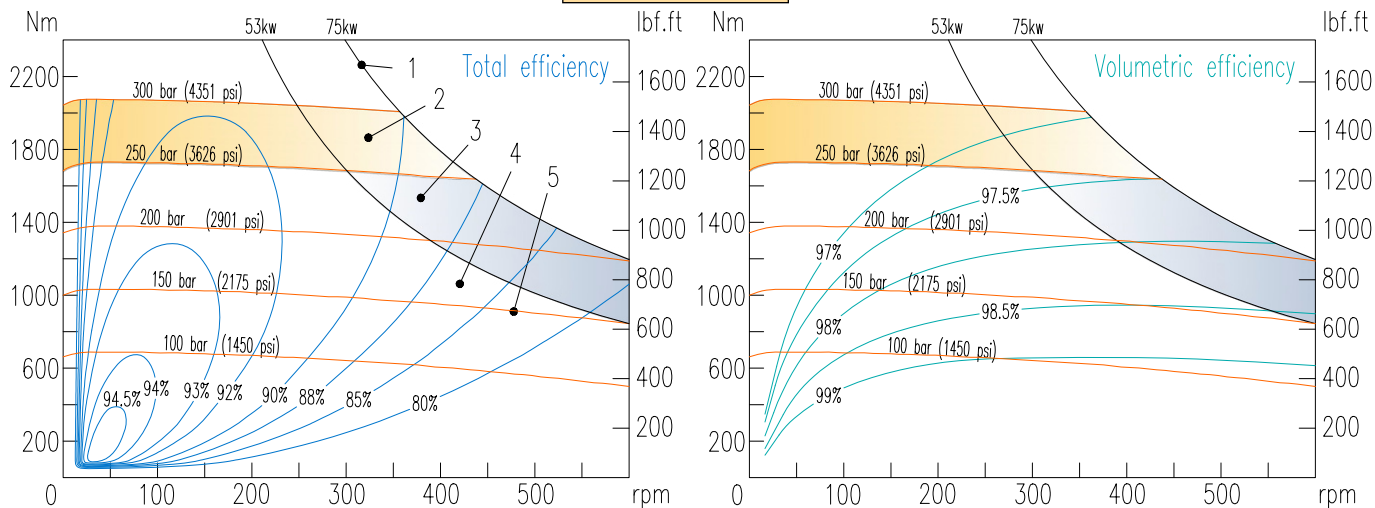

MRE500E

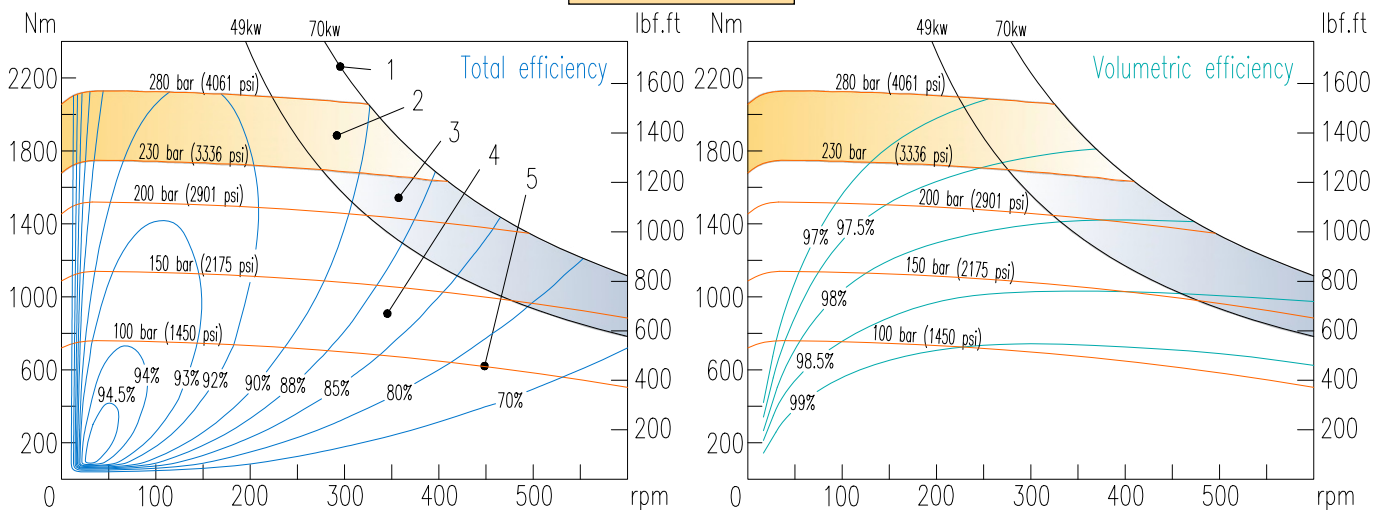

MR600F

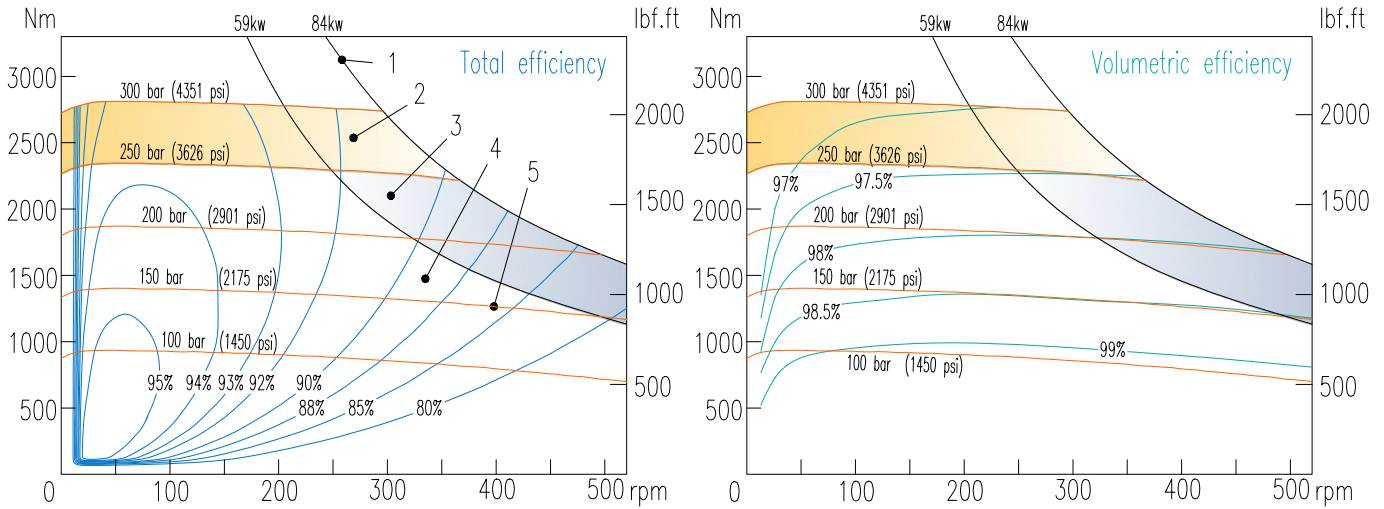

MR700F

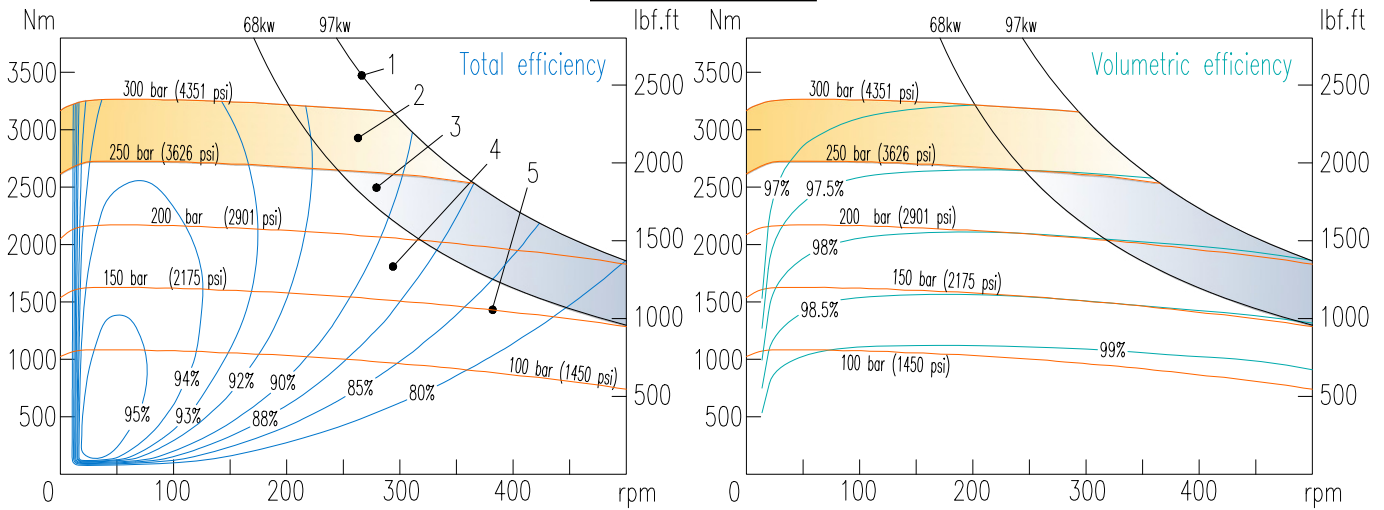

MRE800F

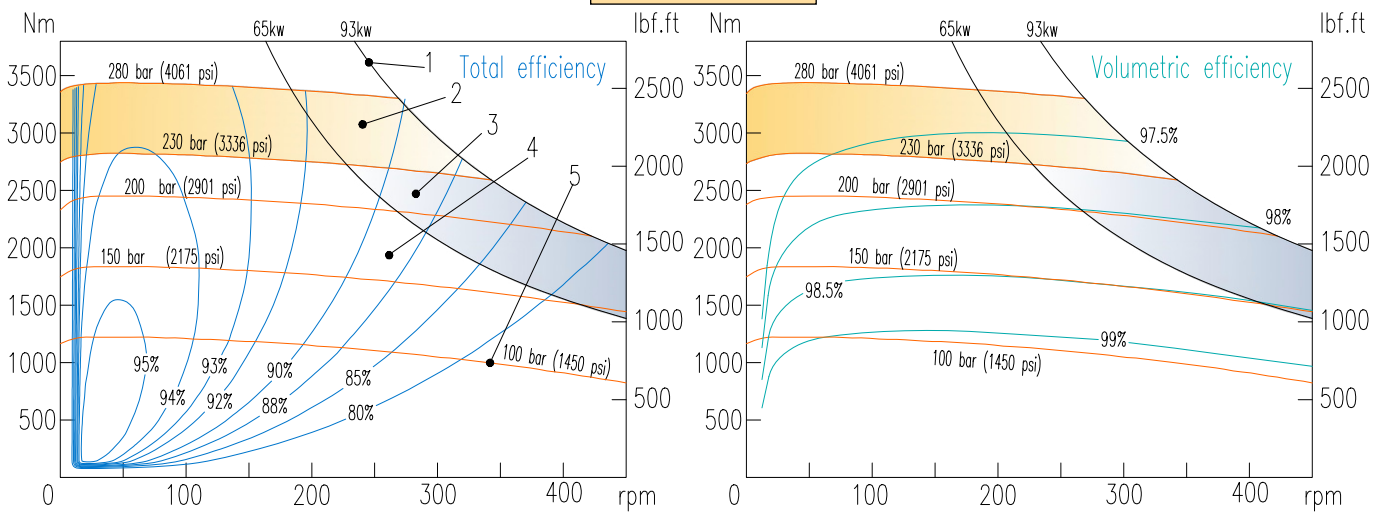

MR1100G

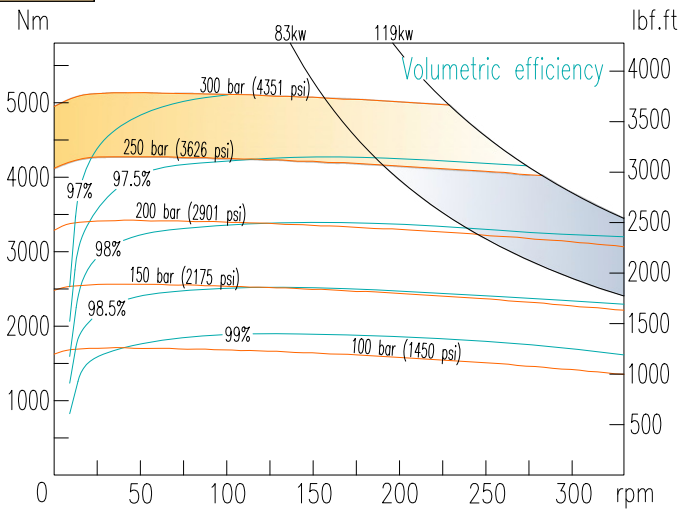
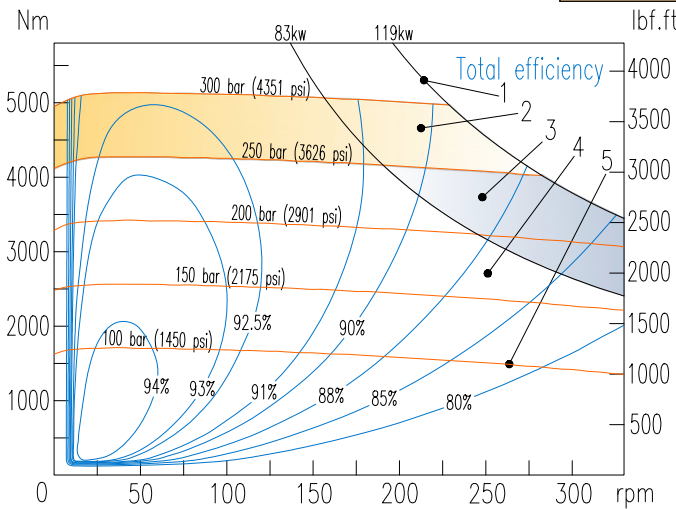

MRE1400G

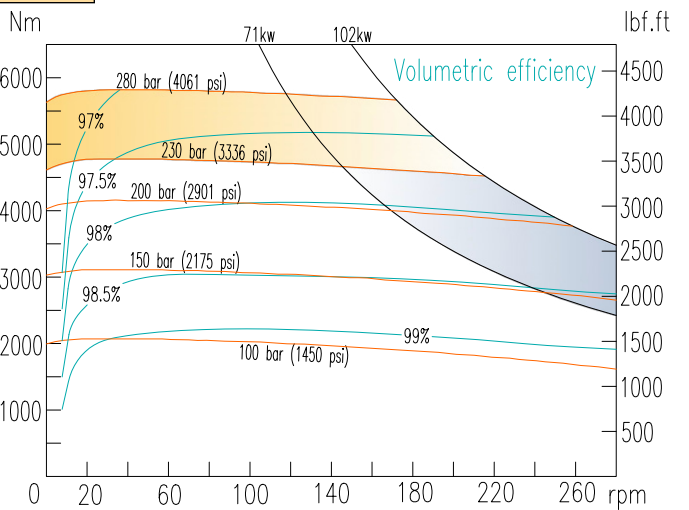
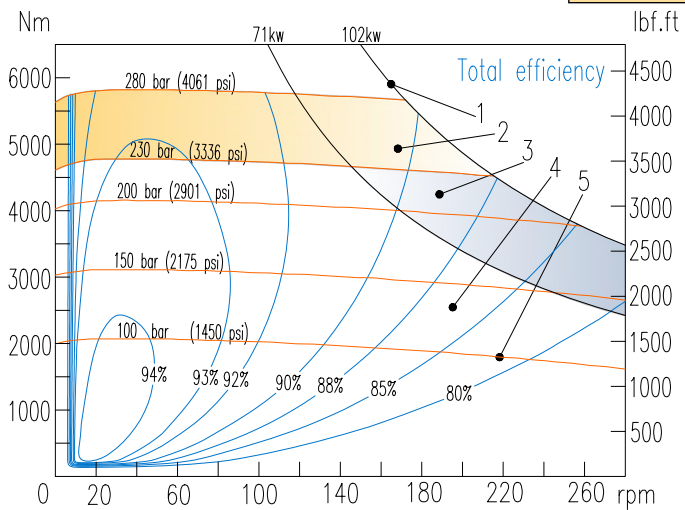

MRA1600G

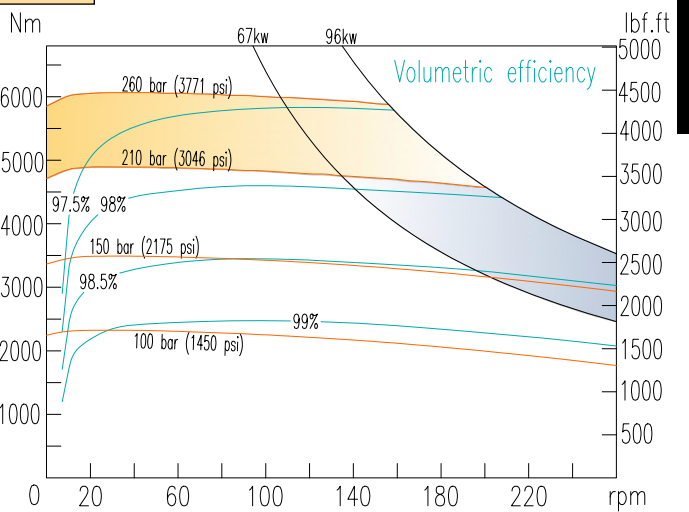
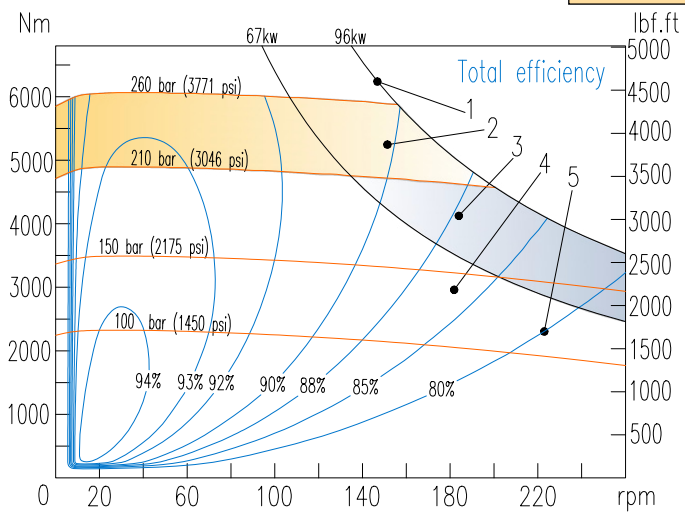

MR1600H

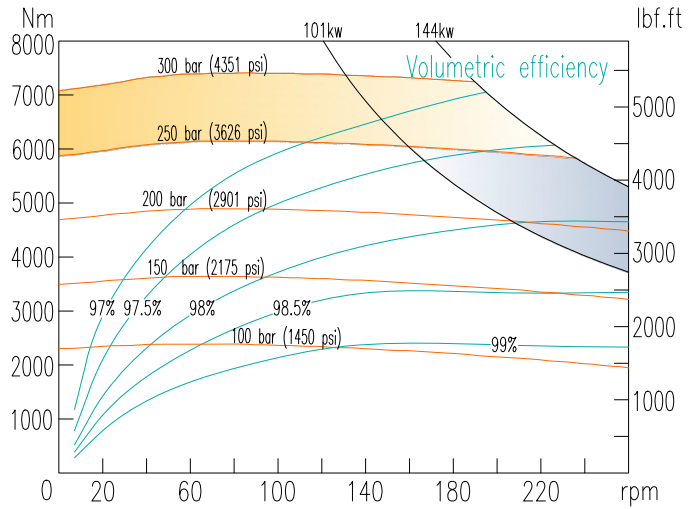
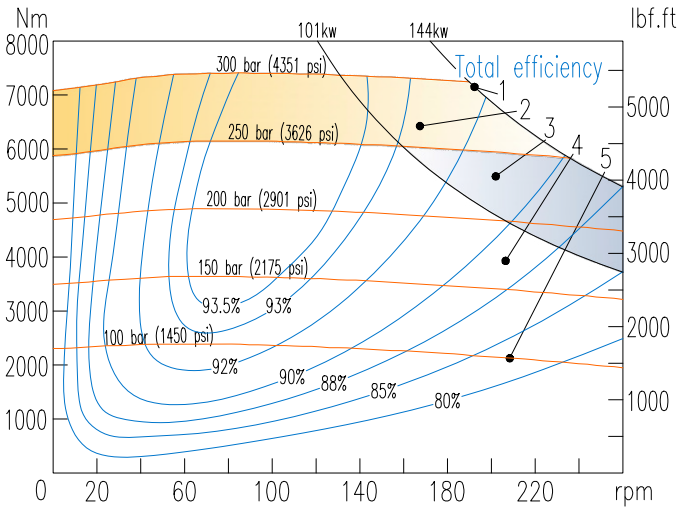

MR1800H

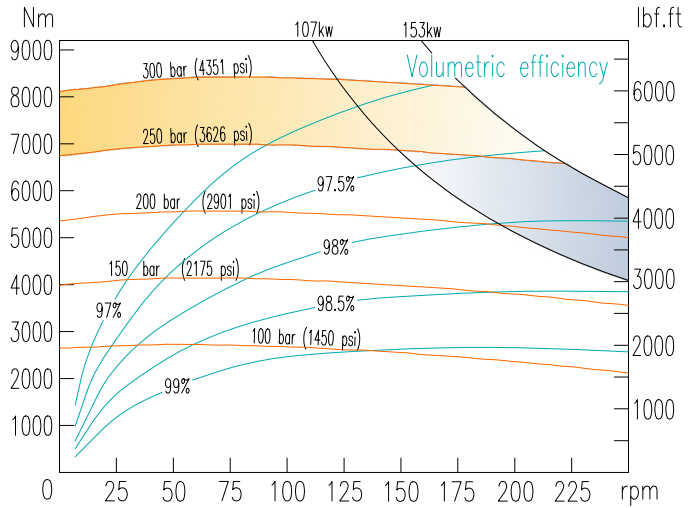
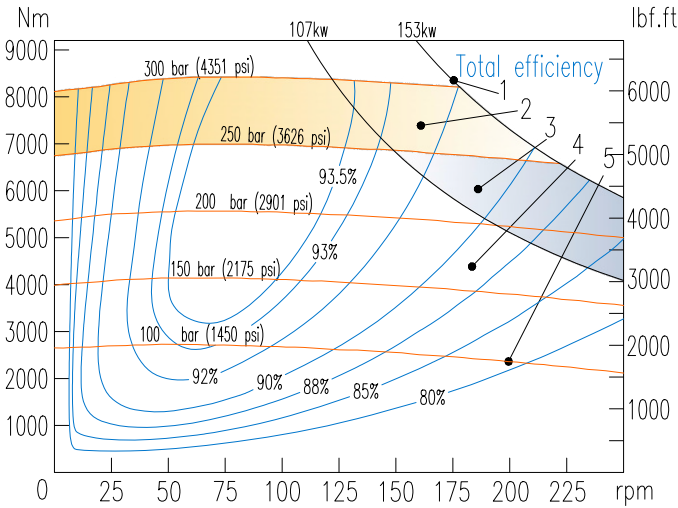

MRE2100H

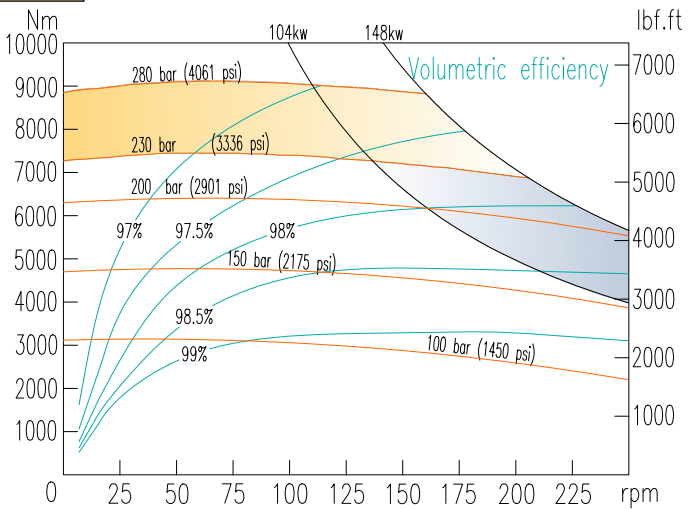
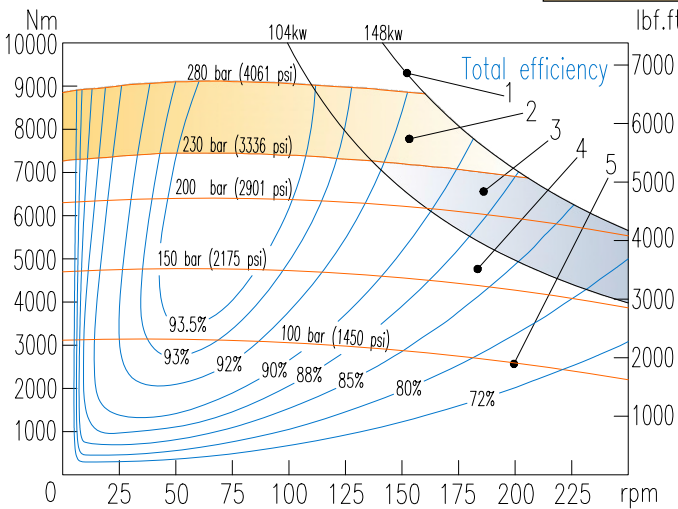

MRA2400H

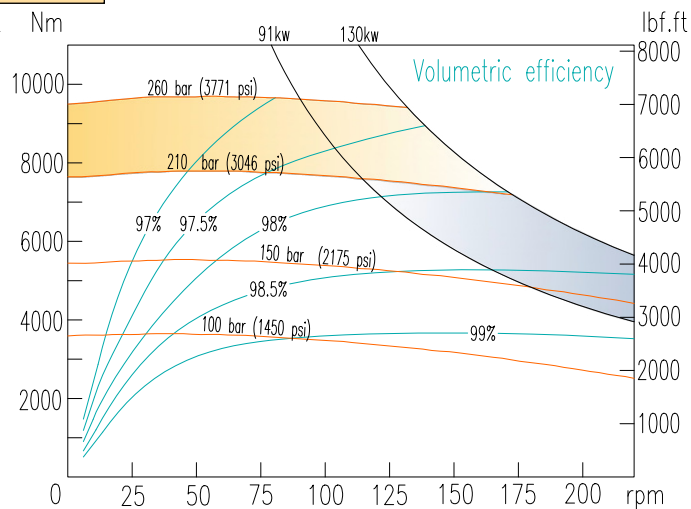
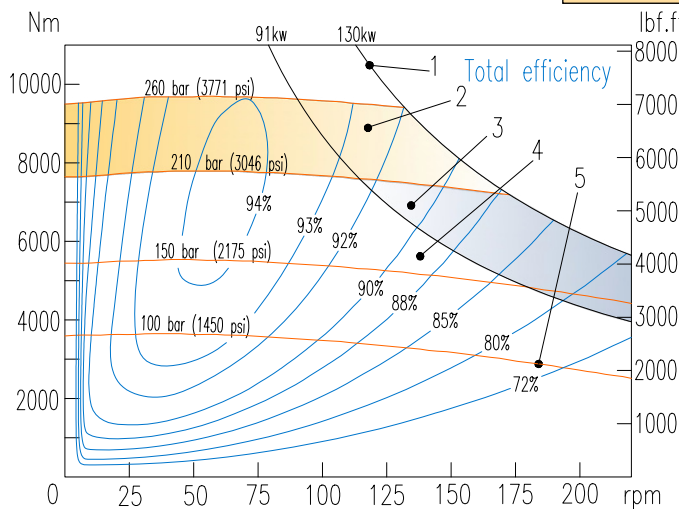

MR2400I

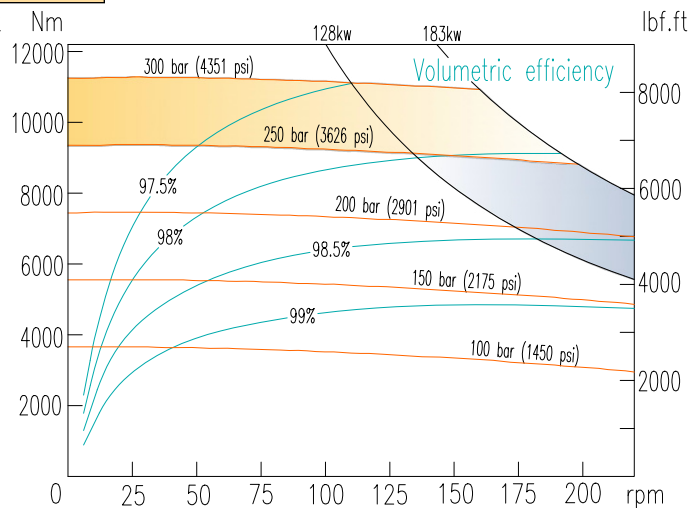
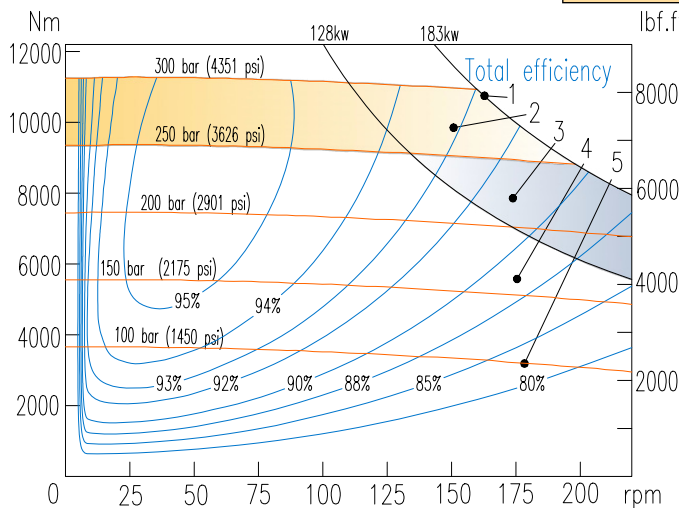

MR2800I

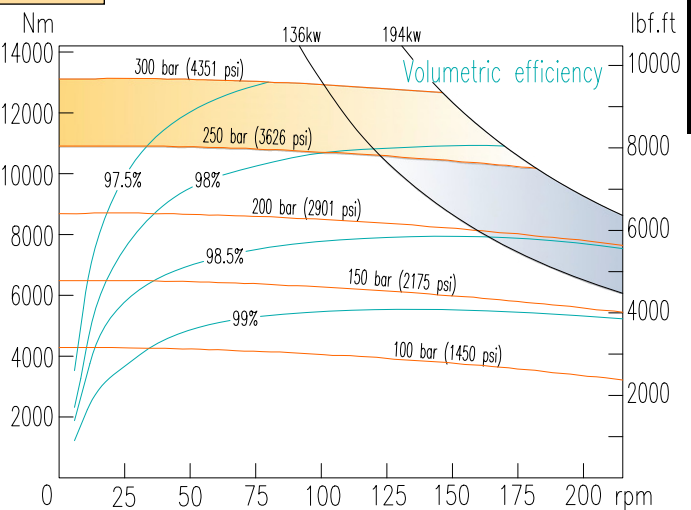
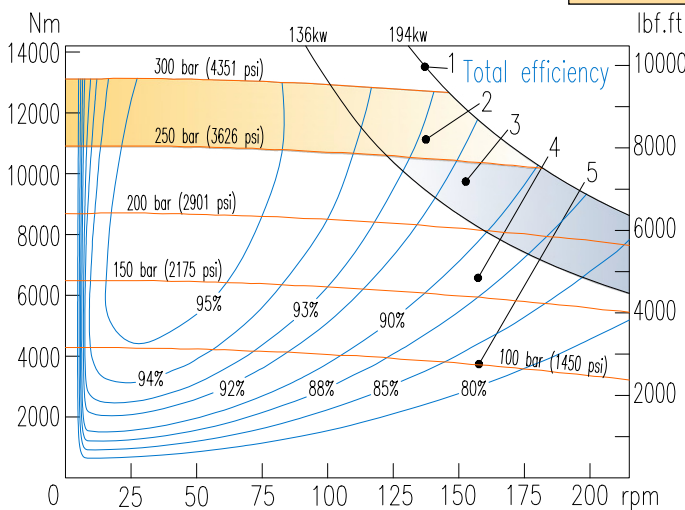

MRE3100I

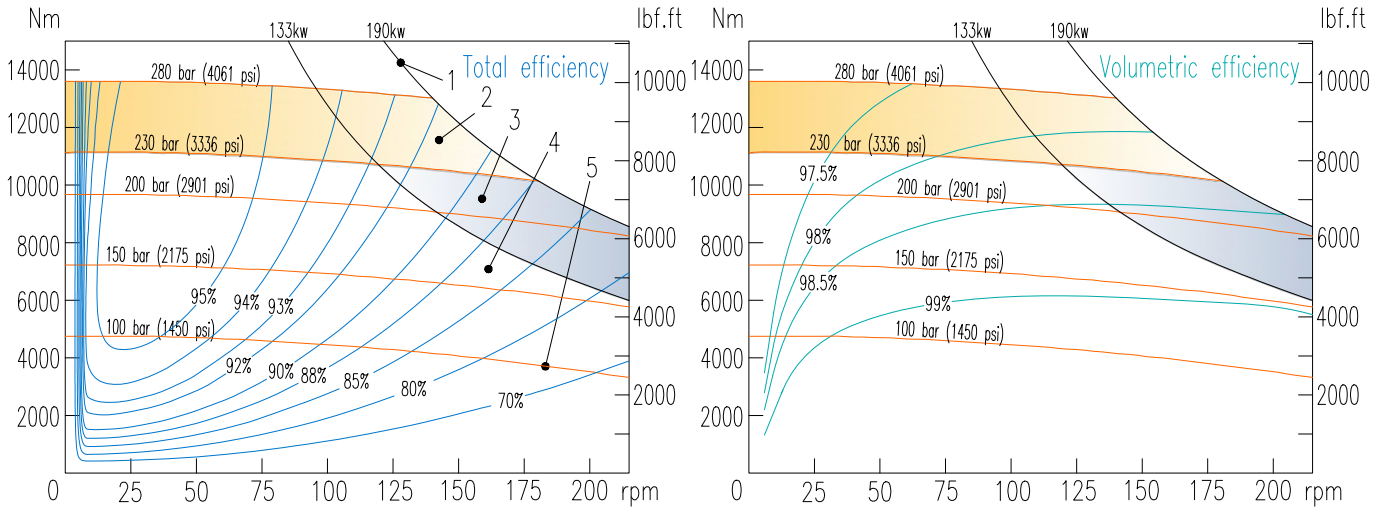

MRA3500I

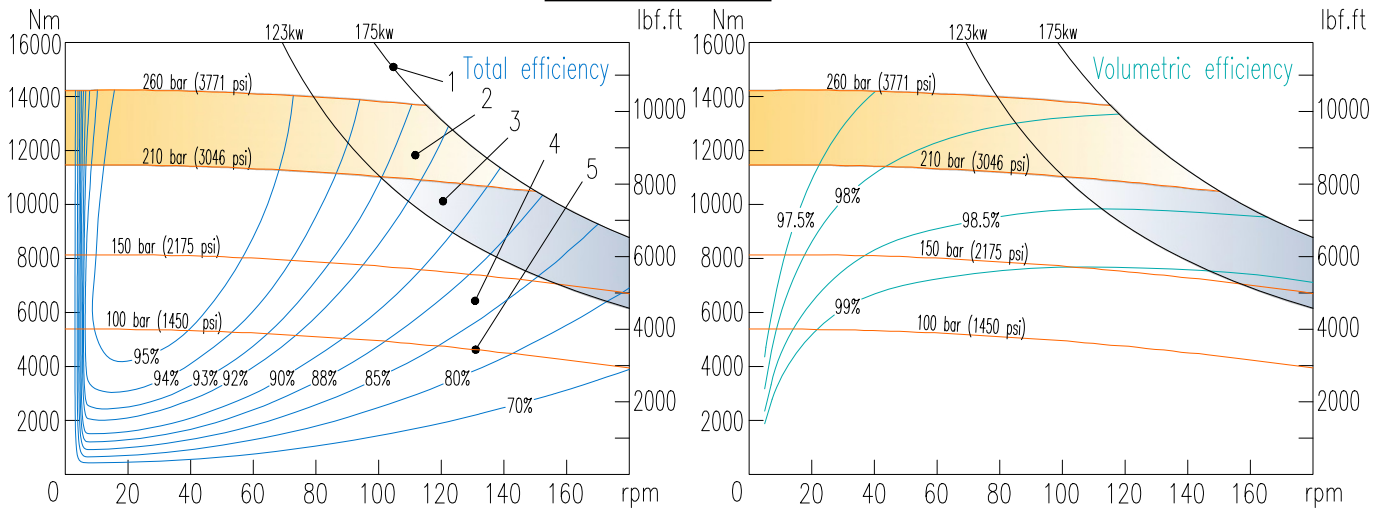

MR3600L

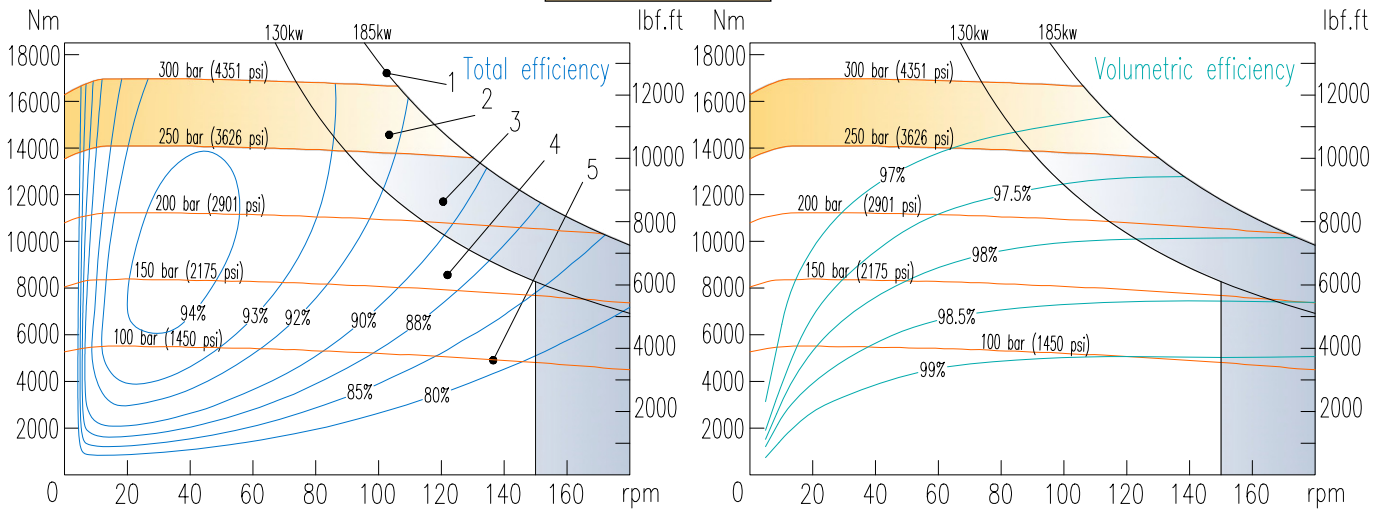

MR4100L

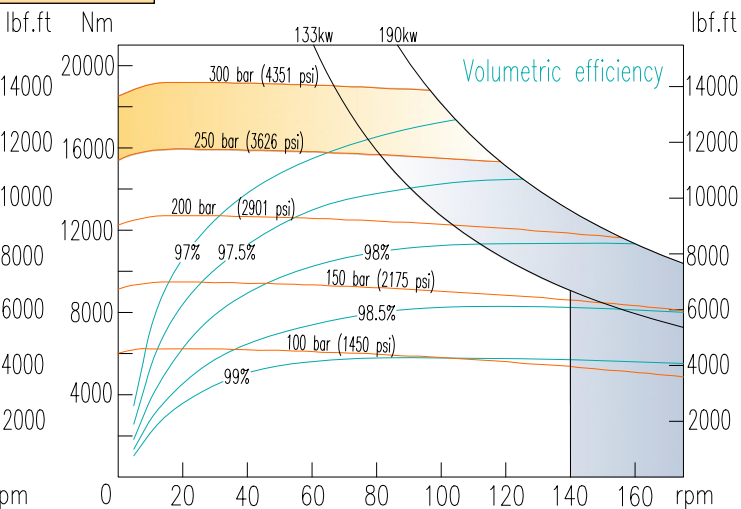
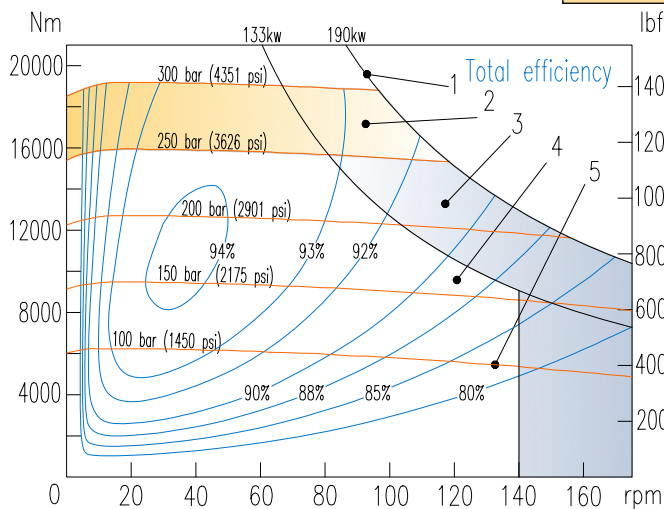

MR4500L

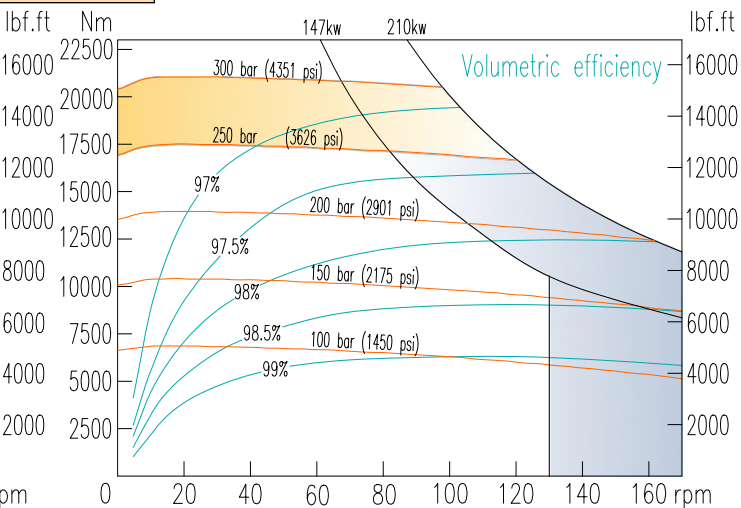
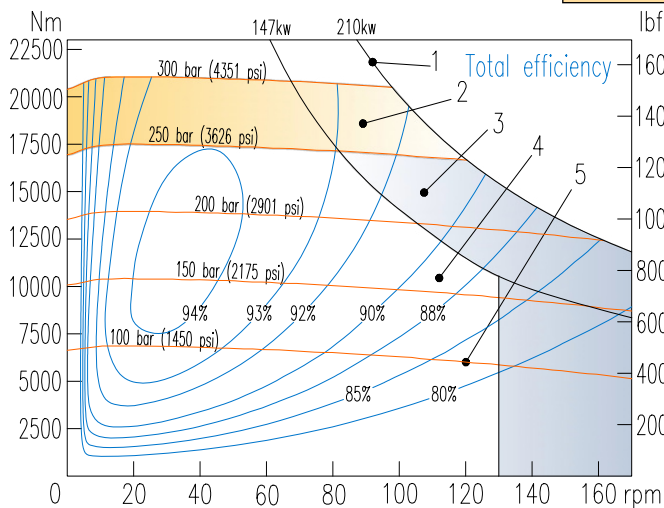

MRE5400L

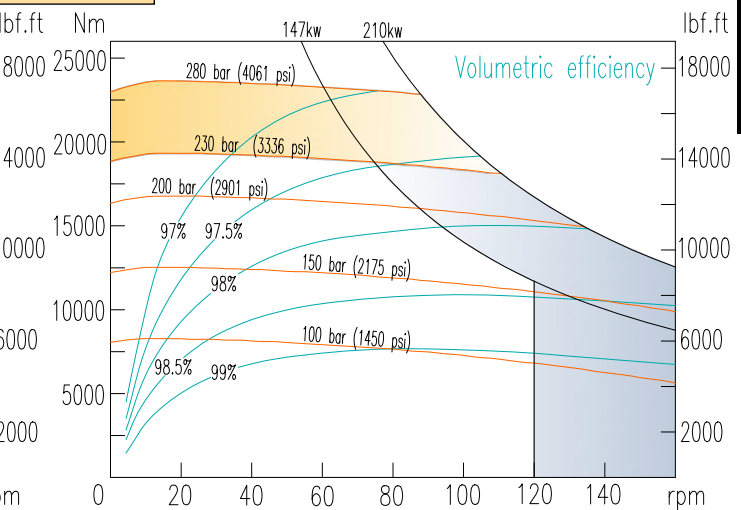
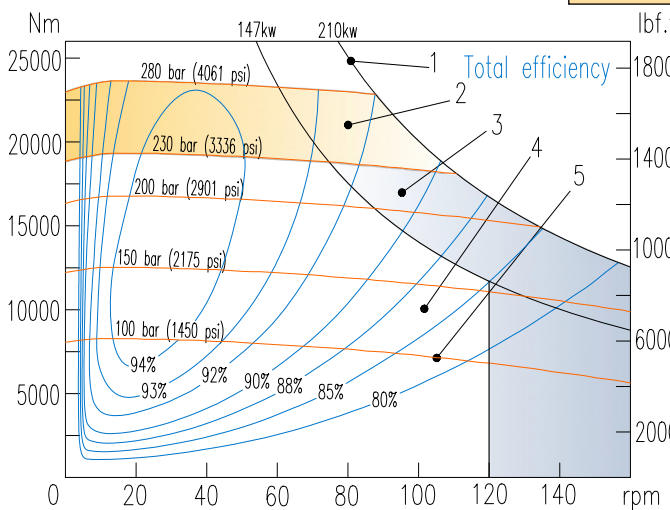

MRA6000L

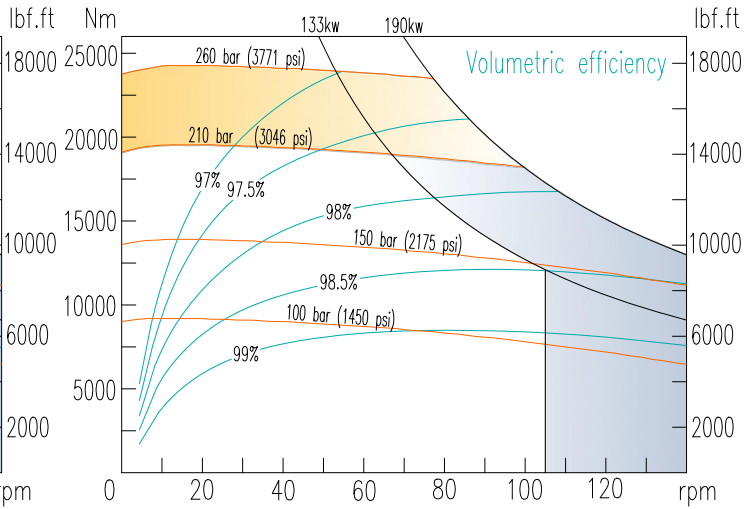
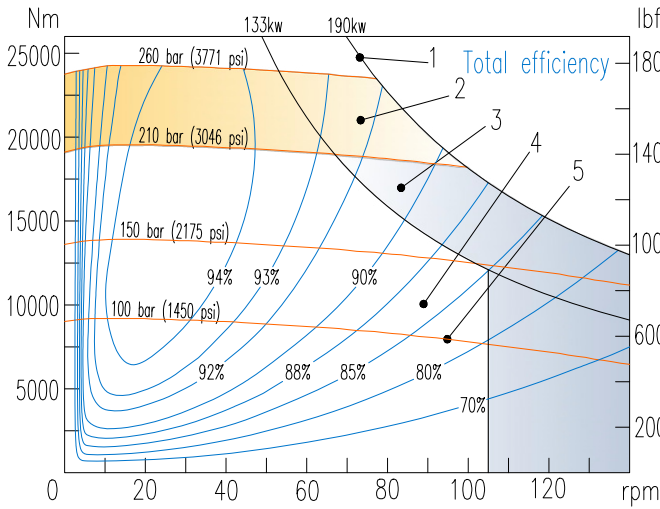

MR6500M

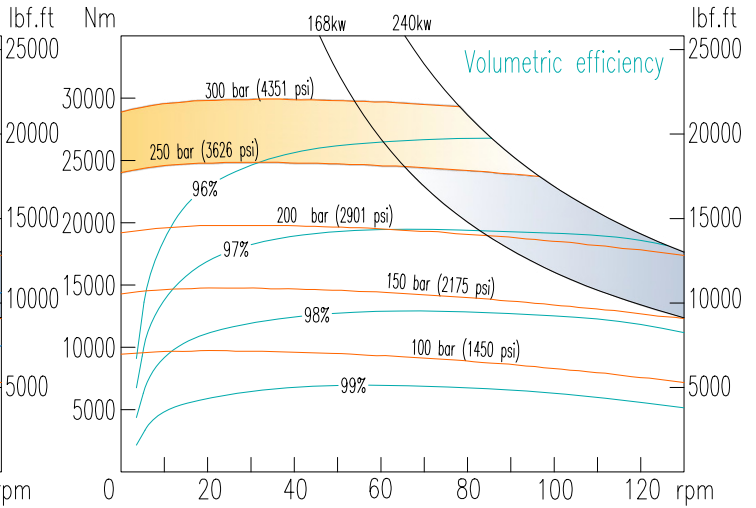
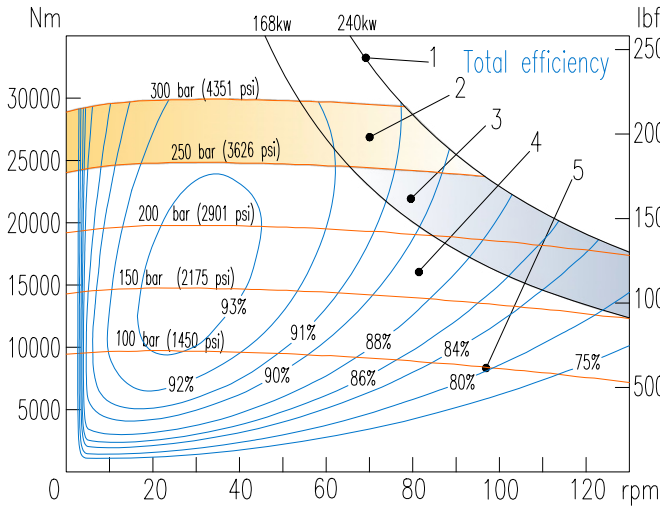

MR7000M

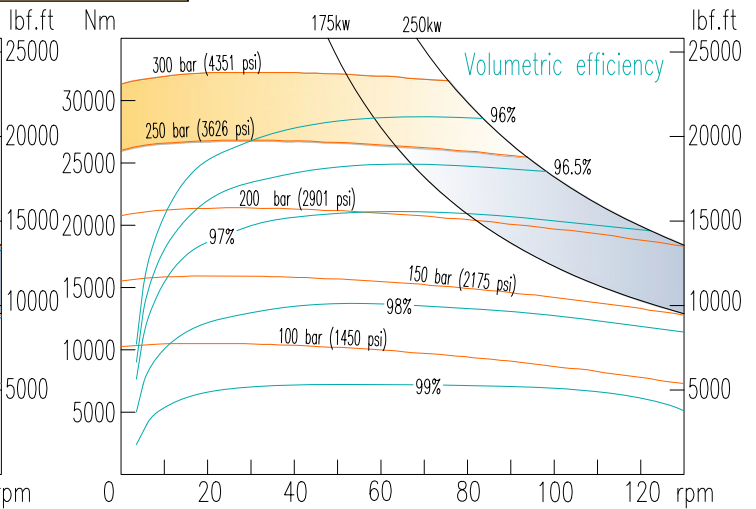
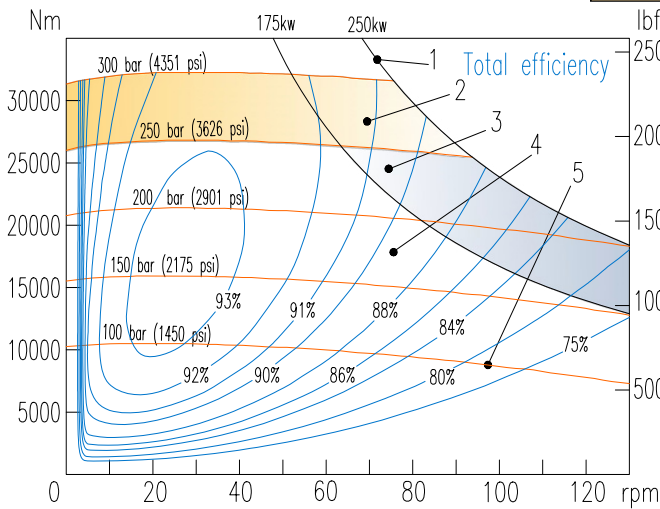

MRE7600M

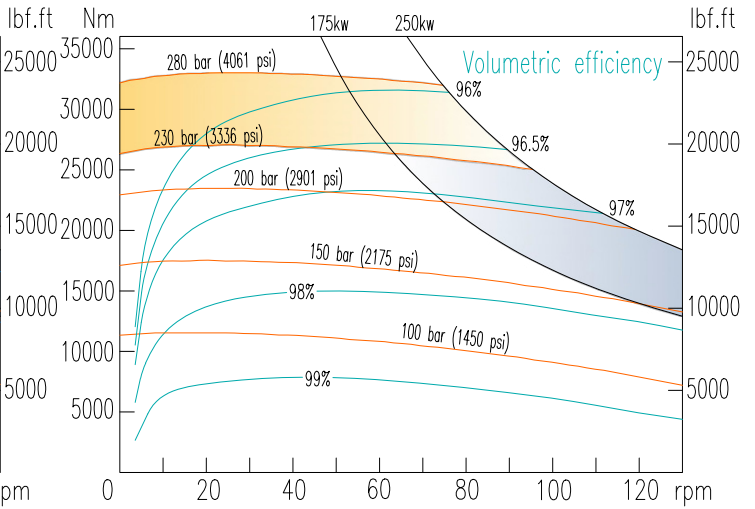
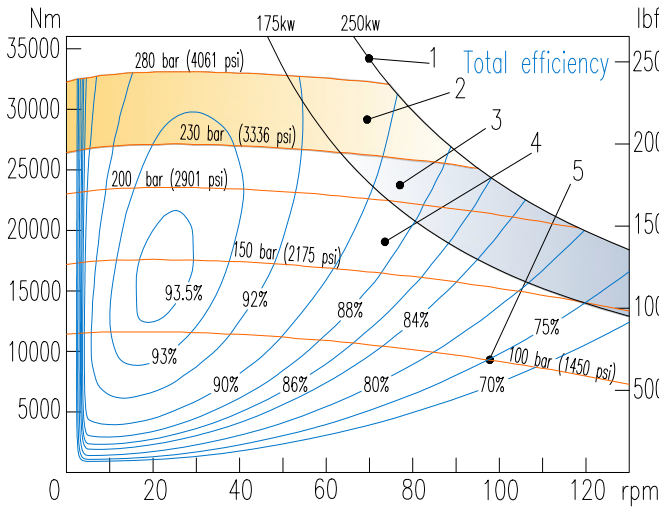

MRE8200M

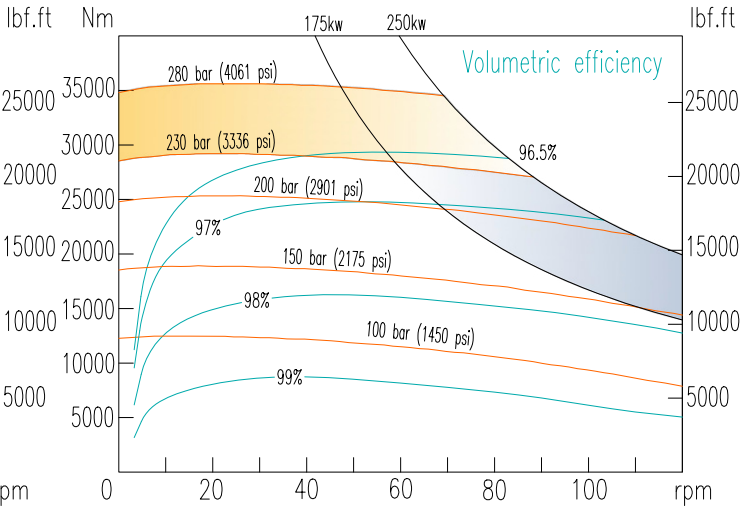
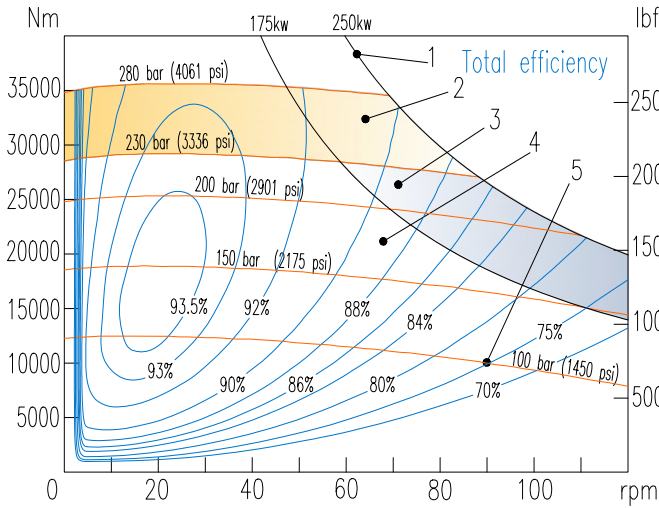

MRA9000M

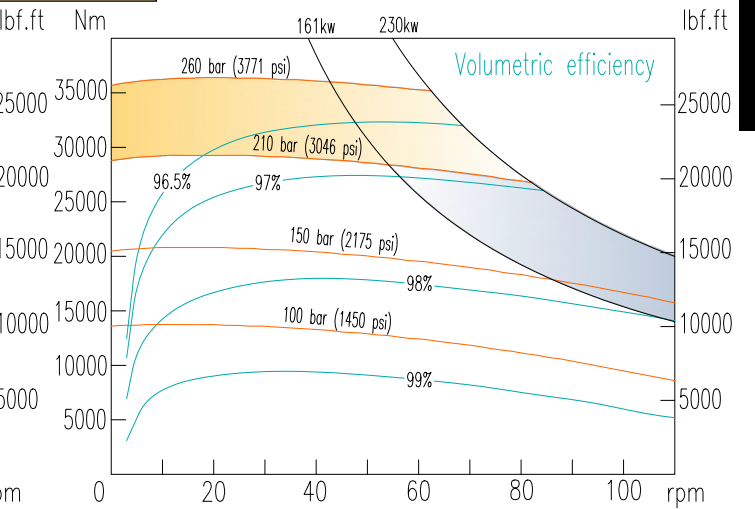
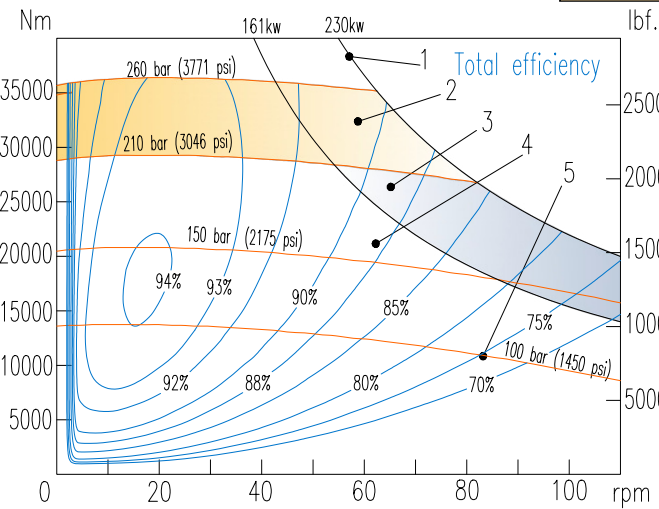

Motor start-up

The motor does not require any special running in, but all residual impurities in the system must be eliminated by running the motor at low speed and with no applied load, granting the minimum necessary inlet pressure.

After a brief period in service, the system filters should be cleaned. This operation will also lead to the air venting from motor cylinders; air inside the motor cylinders may increase the possible noise at the start-up of the motor.

Make sure the motor case has been filled (see “Motor case oil filling” paragraph).

Motor case oil filling

All motors are supplied without lubricating oil. Before start-up, the motor case must be filled in by using the same hydraulic oil used to operate the motor.

The two case drain holes are both plugged, one with a metal plug and the other one with a plastic plug. To fill in the motor case it is necessary:

- to place the motor in its working position, making sure to close the lower case drain hole by means of the metal plug;
- to use the upper case drain hole to fill in the motor case up to the level required, by using the same hydraulic oil used in the system, in order to ensure the perfect lubrication of the two bearings.

The volume of oil necessary to fill in the case has to be selected according to the motor size (see table below):

Motor type	Motor case oil		Motor type	Motor case oil		Motor type	Motor case oil		Motor type	Motor case oil	
	liters	gallons		liters	gallons		liters	gallons		liters	gallons
MR 33 A	1.0	0.26	MRE 330 D	2.0	0.53	MRA 1600 G	6.0	1.58	MR 4500 L	19.0	5.02
MR 57 A			MRA 400 D			MR 1600 H	9.5	2.50	MRE 5400 L		
MR 73 B	1.5	0.40	MR 350 E	MR 1800 H	MR 6000 L						
MR 93 B			MR 400 E	2.8	0.74	MRE 2100 H	MR 6500 M	27	7.13		
MR 110 B	MR 450 E	MRA 2400 H	MR 7000 M								
MR 125 C	1.7	0.45	MRE 500 E	3.3	0.87	MR 2400 I	13.0	3.43	MRE 7600 M		
MR 160 C			MR 600 F			MR 2800 I			MRE 8200 M		
MR 190 C			MR 700 F			MRE 3100 I			MRA 9000 M		
MR 200 D	2.0	0.53	MRE 800 F	6.0	1.58	MRA 3500 I	19.0	5.02			
MR 250 D			MR 1100 G			MR 3600 L					
MR 300 D			MRE 1400 G			MR 4100 L					

Motor case filling volume



Flushing of motor case

Operating within the “Continuous operating area without flushing” (number 4 in operating diagrams from page 34 to page 47 - according to motor type) does not require any additional cooling of the motor case.

For operating conditions out of the “Continuous operating area without flushing”, additional cooling oil is required to avoid high temperature in the motor case (areas number 2 and 3 in operating diagrams from page 34 to page 47 - according to motor type).

Flushing can be also necessary when the operating performances are inside the “Continuous operating area without flushing”, but the system is not able to ensure the minimum viscosity conditions requested by the motor as specified at pages 32 and 33.

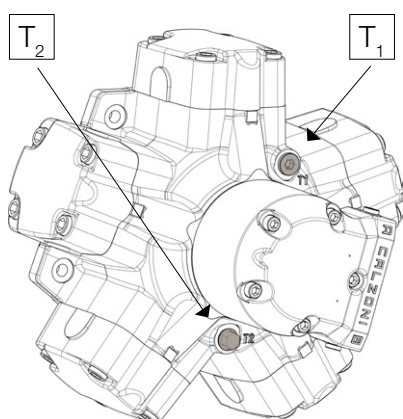

Motor drain and flushing connections

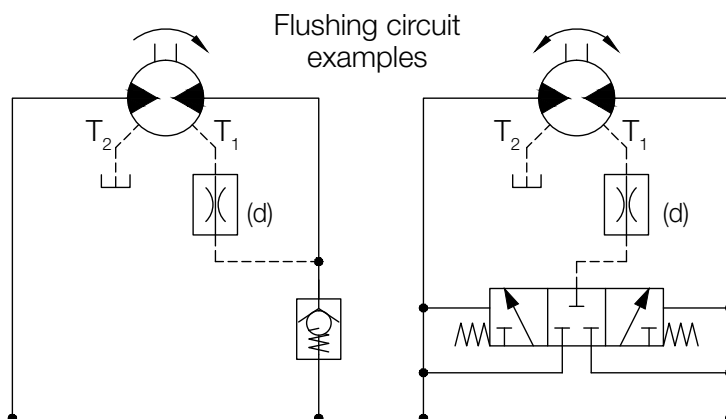

Mono-directional rotation

Bi-directional rotation

Motor type	Flushing flow		Motor type	Flushing flow		Motor type	Flushing flow		Motor type	Flushing flow	
	lpm	gpm		lpm	gpm		lpm	gpm		lpm	gpm
MR 33 A	5	1.3	MRE 330 D	6	1.6	MRA 1600 G	10	2.6	MR 4500 L	20	5.3
MR 57 A			MRA 400 D			MR 1600 H			MR 5400 L		
MR 73 B			MR 350 E	MR 1800 H	MRA 6000 L						
MR 93 B			8	2.1	MRE 2100 H	MR 6500 M					
MR 110 B					MR 400 E	MRA 2400 H	MR 7000 M				
MR 125 C	MRE 500 E	MR 2400 I			MRE 7600 M						
MR 160 C	6	1.6	MR 600 F	15	4	MR 2800 I	MRE 8200 M				
MR 190 C			MR 700 F			MRE 3100 I	MRA 9000 M				
MR 200 D			10			2.6	MRA 3500 I				
MR 250 D							MR 1100 G	MR 3600 L			
MR 300 D			MRE 1400 G			MR 4100 L					

Motor case flushing flow

The motor return line can be used as source flow to flush the motor case (see “Flushing circuit examples on page 49). The requested flow rate can be obtained selecting the correct restrictor diameter (d) according to the differential pressure between the motor case and the return line.

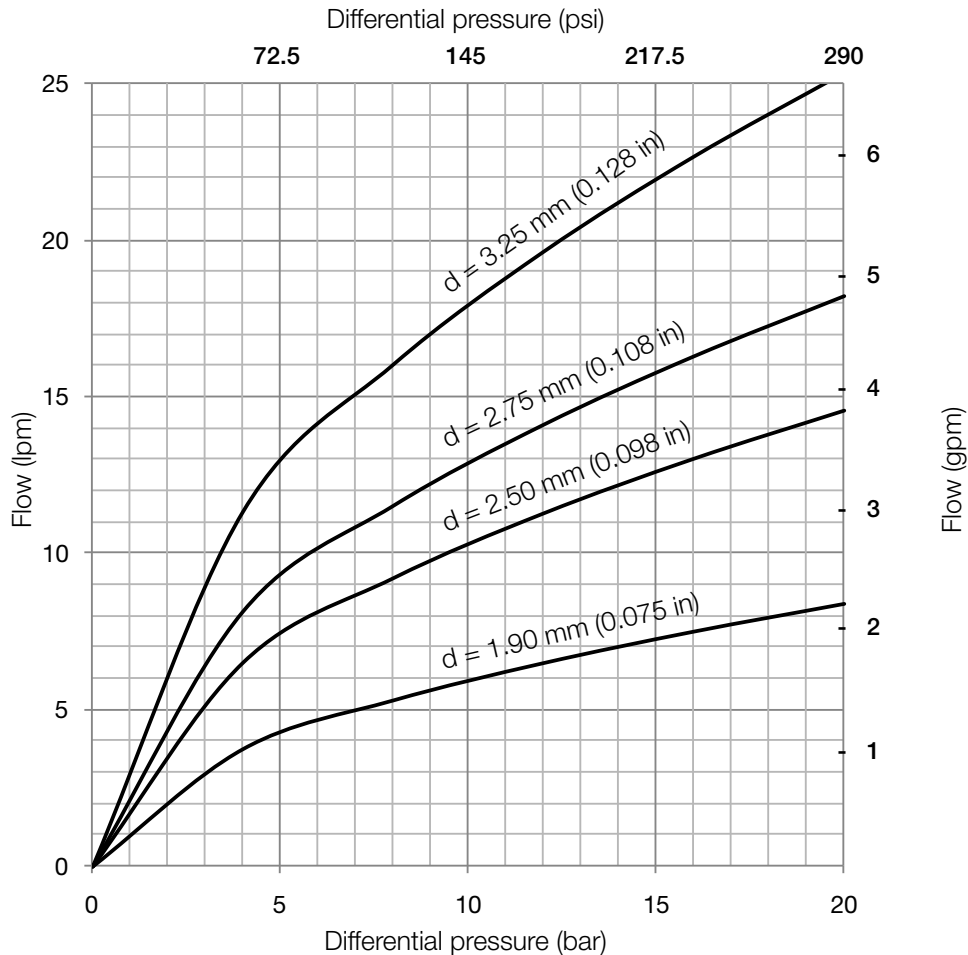

Braking mode and pumping operation

When operating in braking mode (motor operates as a pump), charge pressure is required at the inlet port according to the following formulas (metric unit on the left, imperial/US unit on the right):

$$p = p_0 + A \cdot n + B \cdot n^2 \quad \text{bar}$$

$$p = 14.5 \cdot (p_0 + A \cdot n + B \cdot n^2) \quad \text{psi}$$

where n is the motor speed (rpm) and the terms A, B and p0 can be obtained from the table below according to the motor type.

Motor type	p ₀	A	B	Motor type	p ₀	A	B	Motor type	p ₀	A	B	Motor type	p ₀	A	B
MR 33 A	4	2.8·10 ⁻³	8.0·10 ⁻⁶	MRE 330 D	2	1.3·10 ⁻²	4.0·10 ⁻⁵	MRA 1600 G	2	1.4·10 ⁻²	3.2·10 ⁻⁴	MR 4500 L	2	5.5·10 ⁻²	4.8·10 ⁻⁴
MR 57 A	4	1.1·10 ⁻²	6.0·10 ⁻⁶	MRA 400 D	2	1.4·10 ⁻²	4.5·10 ⁻⁵	MR 1600 H	2	1.4·10 ⁻²	3.2·10 ⁻⁴	MRE 5400 L	2	6.0·10 ⁻²	7.0·10 ⁻⁴
MR 73 B	4	9.0·10 ⁻³	1.1·10 ⁻⁵	MR 350 E	2	1.2·10 ⁻²	4.0·10 ⁻⁵	MR 1800 H	2	1.5·10 ⁻²	3.5·10 ⁻⁴	MRA 6000 L	2	6.8·10 ⁻²	8.0·10 ⁻⁴
MR 93 B	4	1.4·10 ⁻²	1.0·10 ⁻⁵	MR 400 E	2	1.4·10 ⁻²	4.5·10 ⁻⁵	MRE 2100 H	2	1.9·10 ⁻²	4.0·10 ⁻⁴	MR 6500 M	2	7.5·10 ⁻²	9.5·10 ⁻⁴
MR 110 B	4	1.6·10 ⁻²	1.2·10 ⁻⁵	MR 450 E	2	1.5·10 ⁻²	5.0·10 ⁻⁵	MRA 2400 H	2	2.1·10 ⁻²	4.5·10 ⁻⁴	MR 7000 M	2	8.0·10 ⁻²	1.2·10 ⁻³
MR 125 C	2	3.1·10 ⁻³	1.4·10 ⁻⁵	MRE 500 E	2	1.7·10 ⁻²	7.0·10 ⁻⁵	MR 2400 I	2	3.7·10 ⁻²	2.5·10 ⁻⁴	MRE 7600 M	2	8.2·10 ⁻²	1.6·10 ⁻³
MR 160 C	2	6.5·10 ⁻³	1.5·10 ⁻⁵	MR 600 F	2	2.2·10 ⁻²	8.0·10 ⁻⁵	MR 2800 I	2	4.8·10 ⁻²	2.6·10 ⁻⁴	MRE 8200 M	2	8.4·10 ⁻²	1.9·10 ⁻³
MR 190 C	2	7.5·10 ⁻³	1.9·10 ⁻⁵	MR 700 F	2	2.8·10 ⁻²	8.7·10 ⁻⁵	MRE 3100 I	2	5.0·10 ⁻²	3.6·10 ⁻⁴	MRA 9000 M	2	8.7·10 ⁻²	2.2·10 ⁻³
MR 200 D	2	8.0·10 ⁻³	2.0·10 ⁻⁵	MRE 800 F	2	2.9·10 ⁻²	9.0·10 ⁻⁵	MRA 3500 I	2	5.1·10 ⁻²	3.8·10 ⁻⁴				
MR 250 D	2	9.0·10 ⁻³	2.9·10 ⁻⁵	MR 1100 G	2	1.0·10 ⁻²	2.0·10 ⁻⁴	MR 3600 L	2	5.2·10 ⁻²	3.9·10 ⁻⁴				
MR 300 D	2	1.2·10 ⁻²	3.0·10 ⁻⁵	MRE 1400 G	2	1.2·10 ⁻²	4.0·10 ⁻⁴	MR 4100 L	2	5.4·10 ⁻²	4.5·10 ⁻⁴				

ABS and ATEX requirements



Parker Calzoni MR hydraulic motors have been approved by ABS for use on ABS classed vessels (PDA certificate No. 11-GE825176-PDA). Refer to the PDA certificate for Terms of Validity and Service Restrictions.

Parker Calzoni MR hydraulic motors can be provided in conformity to the essential safety requirements according to the ATEX Directive 94/9/EC. The motors, if destined to operate in potentially explosive atmospheres, are designed and realised in conformity to the Safety Essential Requirements (RES) of Annex II of the ATEX Directive 94/9/EC.

The Directive provides the following classification:

- Group II, category 2, operation in gaseous and dusty environment zone 1 and 21;
- Group II, category 3, operation in gaseous and dusty environment zone 2 e 22;
- Maximum surface temperature: class of temperature T4.

When ordering motors destined to operate in potentially explosive atmospheres, please contact Parker Hannifin and specify group, category and application data (a specific code will be assigned to the motor).

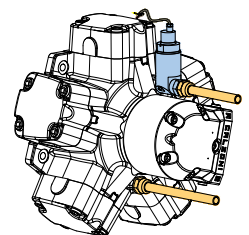

General information

Bearing life can be calculated for that part of the load/life curve (shown below) that is designated 'Bearing fatigue'. 'Components wear' and 'Other causes', caused by material fatigue and fluid contamination, should also be taken into consideration when estimating the service life of a motor in a specific application.

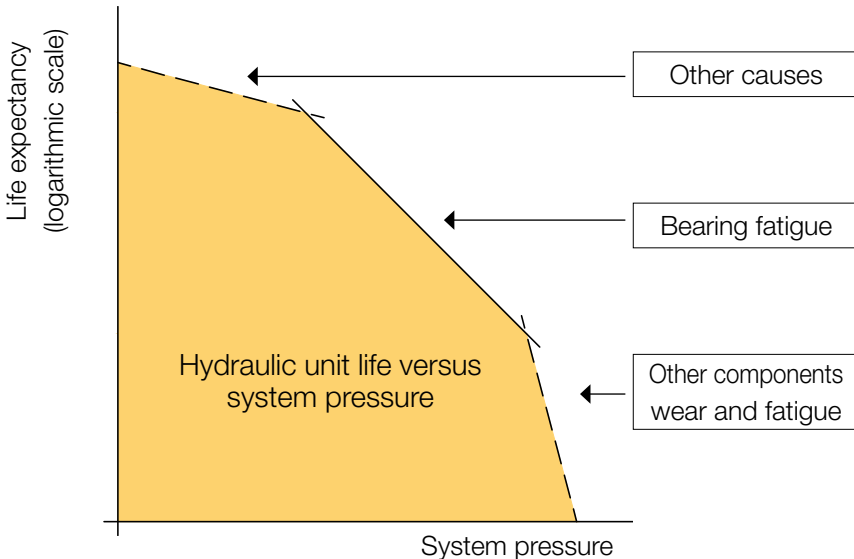

Bearing life (in hours), depends on system pressure, operating speed, external shaft loads, fluid viscosity in the case, and fluid contamination level.

When the motors operate inside the catalogue parameters, the bearing life can be equated to the motor life (service life of the motor before maintenance).

Bearing service life

Bearing L10h life (in hours) can be calculated according to motor speed and pressure (see below formulas, metric unit on the left, imperial/US unit on the right):

$$L_{10h} = \frac{16\,666}{n} \left(\frac{K}{p} \right)^{3.33}$$

p = pressure (bar)
n = speed (rpm)

$$L_{10h} = \frac{16\,666}{n} \left(\frac{14.5 \cdot K}{p} \right)^{3.33}$$

p = pressure (psi)
n = speed (rpm)

L10h is the basic rating life at 90% reliability: it means that 90% of the bearings survive at least the calculated number of hours. Statistically, 50% of the bearings will survive at least five times the L10h life.

Motor type	K
MR 33 A	2900
MR 57 A	2900
MR 73 B	1800
MR 93 B	1800
MR 110 B	1800
MR 125 C	1280
MR 160 C	1280
MR 190 C	1280
MR 200 D	1280
MR 250 D	1280
MR 300 D	1280

Motor type	K
MRE 330 D	1170
MRA 400 D	1170
MR 350 E	1500
MR 400 E	1500
MR 450 E	1500
MRE 500 E	1360
MR 600 F	1240
MR 700 F	1240
MRE 800 F	1090
MR 1100 G	1120
MRE 1400 G	920

Motor type	K
MRA 1600 G	870
MR 1600 H	1040
MR 1800 H	1040
MRE 2100 H	900
MRA 2400 H	840
MR 2400 I	1140
MR 2800 I	1140
MRE 3100 I	1020
MRA 3500 I	950
MR 3600 L	1170
MR 4100 L	1170

Motor type	K
MR 4500 L	1170
MRE 5400 L	980
MRA 6000 L	910
MR 6500 M	900
MR 7000 M	900
MRE 7600 M	770
MRE 8200 M	770
MRA 9000 M	680

Under variable operating conditions bearing life can be predicted using the equation:

$$L_{10h} = \frac{1}{\frac{U_1}{L_{10h_1}} + \frac{U_2}{L_{10h_2}} + \frac{U_3}{L_{10h_3}} + \dots}$$

Where:

L10h = rating life (hours)

L10h₁, L10h₂, ... = fraction rating lives under constant conditions 1, 2, ... (hours)

U₁, U₂, ... = life fraction under the conditions 1, 2, ... (Note: U₁+U₂+...+U_n=1)

Calzoni motors are designed with bearings that can accept external radial loads. External radial shaft loads impact unit lifetime and the bearing life will be a function of the load position, orientation and operating conditions. In applications with external radial shaft loads, minimize the impact by positioning the load close to the motor mounting surface.

Please contact Parker Hannifin to determine motor life in a specific application, taking into consideration also external shaft forces and fluid viscosity.

Quick motor selection

- 1 Required motor output torque (M) and system pressure (p) are known; calculate theoretical specific motor torque (T_s) as follows (metric unit on the left, imperial/US unit on the right):

$$T_s = \frac{M}{p} \quad \frac{Nm}{bar}$$

$$T_s = \frac{M}{1000 \cdot p} \quad \frac{lbf \cdot ft}{1000 \cdot psi}$$

Example:

M = 20000 N·m (14750 lbf·ft), p = 200 bar (2900 psi) >>> T_s = 100 Nm/bar (5086 lbf·ft/1000psi)

- 2 Select an hydraulic motor with a specific torque value bigger than the calculated one (see motor technical data from page 8 to page 11).

Example:

>>> selected motor is MR6500M with T_s = 103.6 Nm/bar (5229 lbf·ft/1000psi)

- 3 Identify motor total efficiency (η_T) and volumetric efficiency (η_V) at the working parameters (see operating diagrams from page 34 to page 47); calculate mechanical efficiency (η_M = η_T/η_V).

Example:

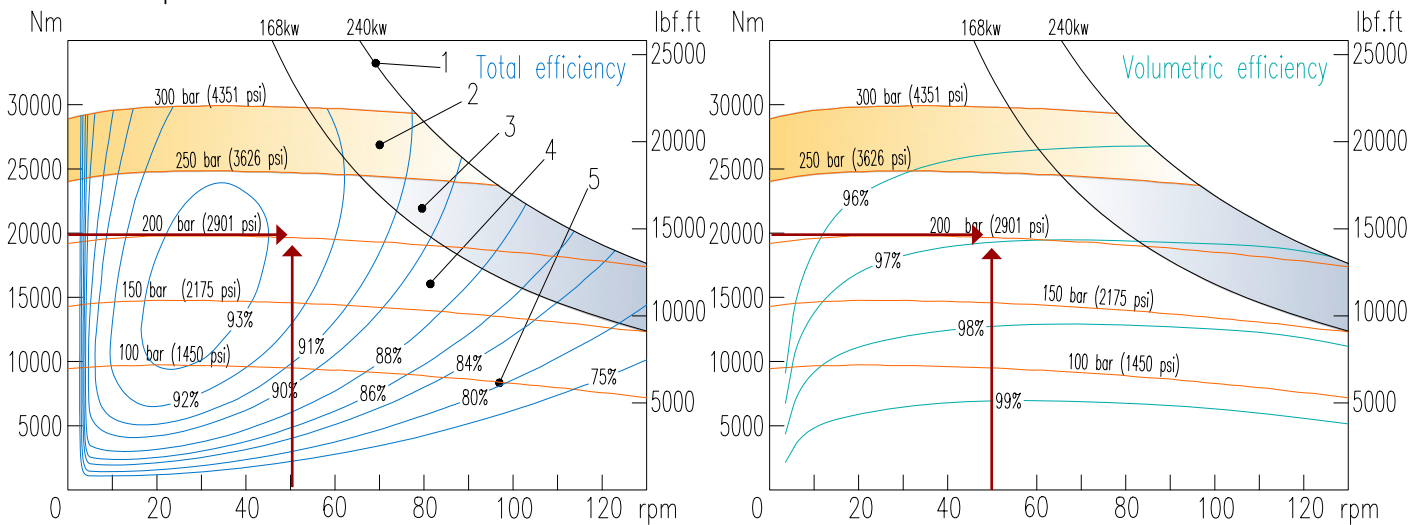

>>> η_T = 92.5%; η_V = 97%; η_M = 95.3%

- 4 Calculate motor working pressure and required pumping flow as follows:

$$p = \frac{M}{T_s \cdot \eta_M} \quad bar$$

$$p = \frac{M}{1000 \cdot T_s \cdot \eta_M} \quad psi$$

$$Q = \frac{V \cdot n}{1000 \cdot \eta_V} \quad lpm$$

$$Q = \frac{V \cdot n}{231 \cdot \eta_V} \quad gpm$$

Example:

>>> calculated pressure is p = 203 bar (2945 psi); required pumping flow is Q = 333 lpm (88 gpm).

Sales Offices Worldwide

AE – UAE, Dubai

Tel: +971 4 8127100
parker.me@parker.com

AR – Argentina, Buenos Aires

Tel: +54 3327 44 4129

AT – Austria, Wiener Neustadt

Tel: +43 (0)2622 23501-0
parker.austria@parker.com

AT – Eastern Europe,

Wiener Neustadt
Tel: +43 (0)2622 23501 900
parker.easteurope@parker.com

AU – Australia, Castle Hill

Tel: +61 (0)2-9634 7777

AZ – Azerbaijan, Baku

Tel: +994 50 2233 458
parker.azerbaijan@parker.com

BE/LU – Belgium, Nivelles

Tel: +32 (0)67 280 900
parker.belgium@parker.com

BR – Brazil, Cachoeirinha RS

Tel: +55 51 3470 9144

BY – Belarus, Minsk

Tel: +375 17 209 9399
parker.belarus@parker.com

CA – Canada, Milton, Ontario

Tel: +1 905 693 3000

CH – Switzerland, Etoy

Tel: +41 (0)21 821 87 00
parker.switzerland@parker.com

CL – Chile, Santiago

Tel: +56 2 623 1216

CN – China, Shanghai

Tel: +86 21 2899 5000

CZ – Czech Republic, Klecany

Tel: +420 284 083 111
parker.czechrepublic@parker.com

DE – Germany, Kaarst

Tel: +49 (0)2131 4016 0
parker.germany@parker.com

DK – Denmark, Ballerup

Tel: +45 43 56 04 00
parker.denmark@parker.com

ES – Spain, Madrid

Tel: +34 902 330 001
parker.spain@parker.com

FI – Finland, Vantaa

Tel: +358 (0)20 753 2500
parker.finland@parker.com

FR – France, Contamine s/Arve

Tel: +33 (0)4 50 25 80 25
parker.france@parker.com

GR – Greece, Athens

Tel: +30 210 933 6450
parker.greece@parker.com

HK – Hong Kong

Tel: +852 2428 8008

HU – Hungary, Budapest

Tel: +36 1 220 4155
parker.hungary@parker.com

IE – Ireland, Dublin

Tel: +353 (0)1 466 6370
parker.ireland@parker.com

IN – India, Mumbai

Tel: +91 22 6513 7081-85

IT – Italy, Corsico (MI)

Tel: +39 02 45 19 21
parker.italy@parker.com

JP – Japan, Tokyo

Tel: +81 (0)3 6408 3901

KR – South Korea, Seoul

Tel: +82 2 559 0400

KZ – Kazakhstan, Almaty

Tel: +7 7272 505 800
parker.easteurope@parker.com

MX – Mexico, Apodaca

Tel: +52 81 8156 6000

MY – Malaysia, Shah Alam

Tel: +60 3 7849 0800

NL – The Netherlands,

Oldenzaal
Tel: +31 (0)541 585 000
parker.nl@parker.com

NO – Norway, Asker

Tel: +47 66 75 34 00
parker.norway@parker.com

NZ – New Zealand, Mt Wellington

Tel: +64 9 574 1744

PL – Poland, Warsaw

Tel: +48 (0)22 573 24 00
parker.poland@parker.com

PT – Portugal, Leca da Palmeira

Tel: +351 22 999 7360
parker.portugal@parker.com

RO – Romania, Bucharest

Tel: +40 21 252 1382
parker.romania@parker.com

RU – Russia, Moscow

Tel: +7 495 645-2156
parker.russia@parker.com

SE – Sweden, Spånga

Tel: +46 (0)8 59 79 50 00
parker.sweden@parker.com

SG – Singapore

Tel: +65 6887 6300

SK – Slovakia, Banská Bystrica

Tel: +421 484 162 252
parker.slovakia@parker.com

SL – Slovenia, Novo Mesto

Tel: +386 7 337 6650
parker.slovenia@parker.com

TH – Thailand, Bangkok

Tel: +662 717 8140

TR – Turkey, Istanbul

Tel: +90 216 4997081
parker.turkey@parker.com

TW – Taiwan, Taipei

Tel: +886 2 2298 8987

UA – Ukraine, Kiev

Tel: +380 44 494 2731
parker.ukraine@parker.com

UK – United Kingdom,

Warwick
Tel: +44 (0)1926 317 878
parker.uk@parker.com

US – USA, Cleveland

Tel: +1 216 896 3000

VE – Venezuela, Caracas

Tel: +58 212 238 5422

ZA – South Africa,

Kempton Park
Tel: +27 (0)11 961 0700
parker.southafrica@parker.com

**European Product Information Centre**

Free phone: 00 800 27 27 5374
(from AT, BE, CH, CZ, DE, EE, ES, FI, FR, IE,
IL, IS, IT, LU, MT, NL, NO, PT, SE, SK, UK)

US Product Information Centre

Free phone: 1-800-27 27 537

www.parker.com

Your Local Authorized Parker Distributor